

Reversing the door

Hold the top hinge cover and remove it toward that direction.

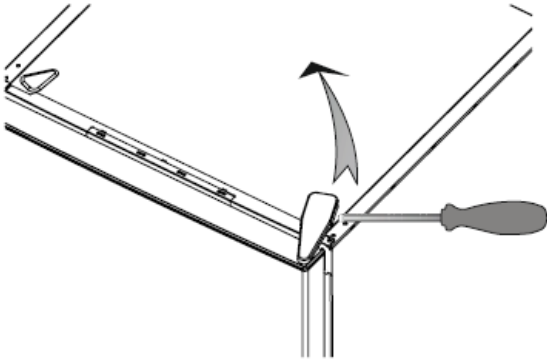

Unscrew the screws fixing the top hinge and remove it.

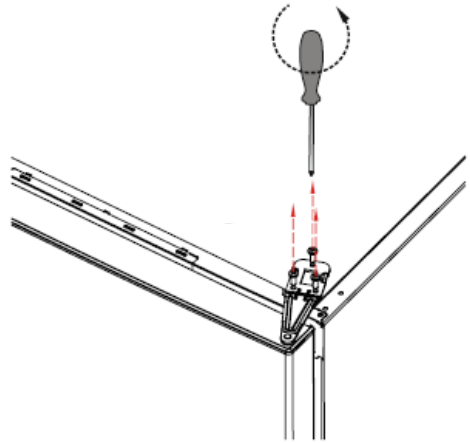

Displace the top door.

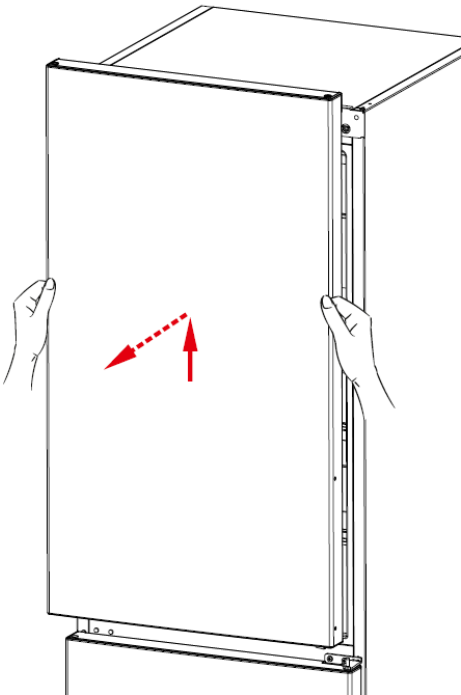

Remove the hinge cover cap and assembly right side.

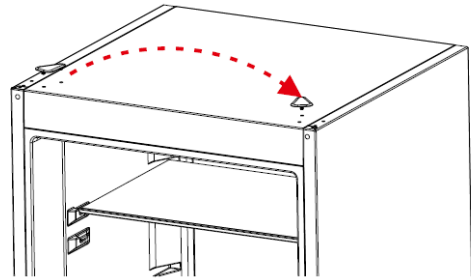

Unscrew the two screws fixing the middle hinge and remove it.

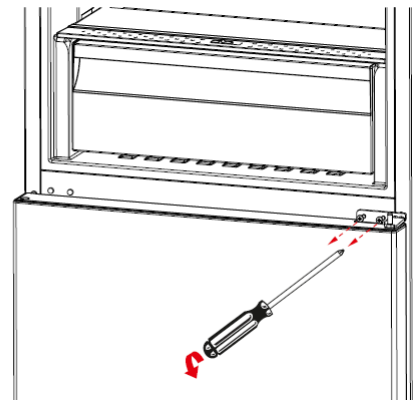

Reversing the door

Displace the bottom door.

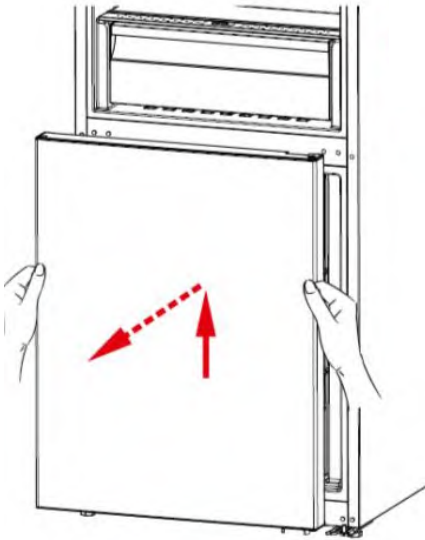

Unscrew the bottom hinge screws.
Unscrew the adjustable foot.

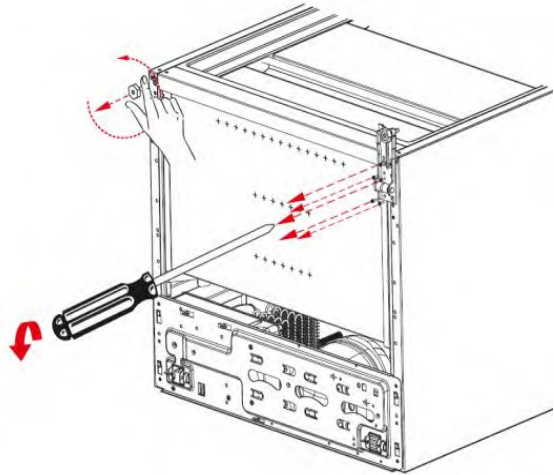

Unscrew the bottom hinge pin and
screw it to other hole.

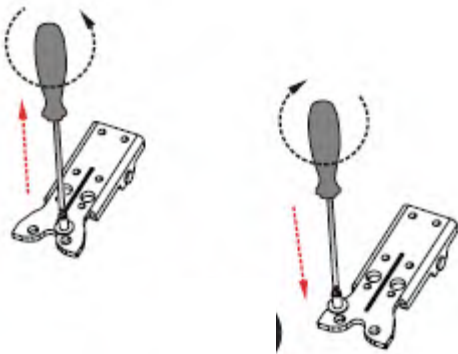

Screw the bottom hinge to the left bottom
side of refrigerator. Screw the adjustable
foot there.

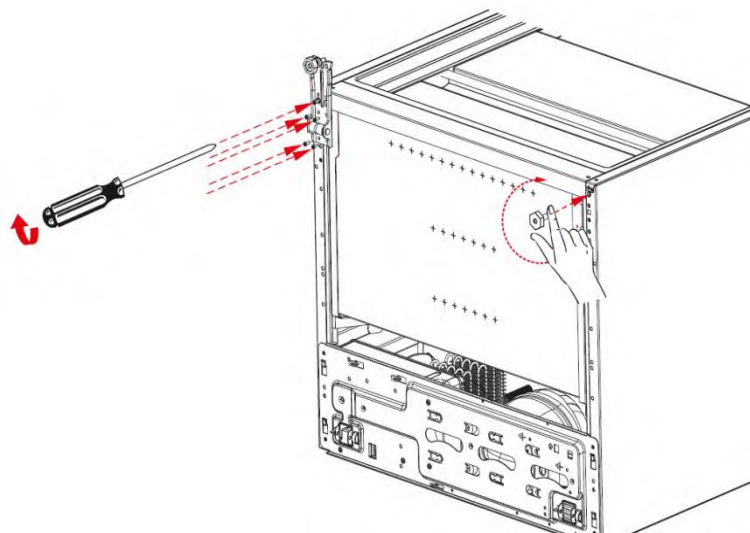

Reversing the door

Replace the top bushing and the top bushing cap at the bottom door.

Unscrew the two screws fixing stopper and stopper support plate under the bottom door. After that screw the other side.

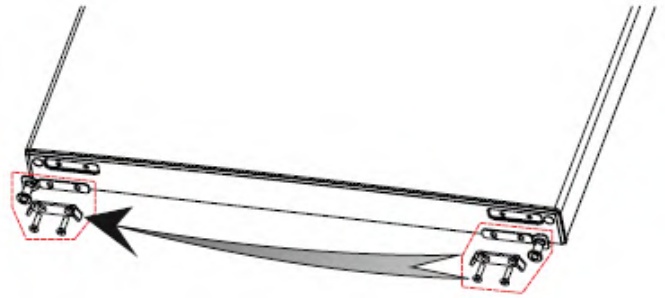
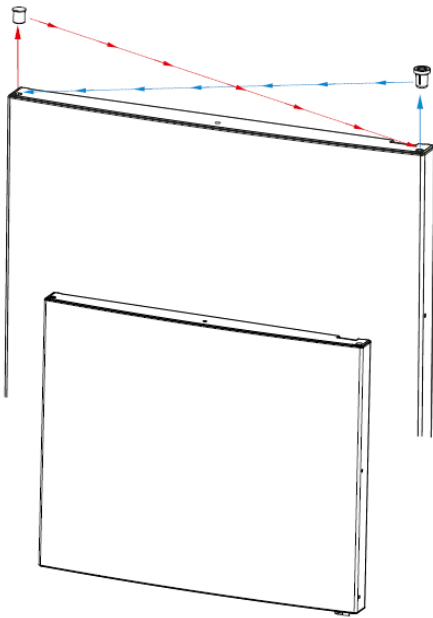

Remove the support plastic and then metal stopper placed under the upper door. Then re screw these parts to the other side symmetrically.

(remember the screw for the metal part must be screwed to the hole which is closer to the bushing). Do not use cordless screwdriver for these screws.

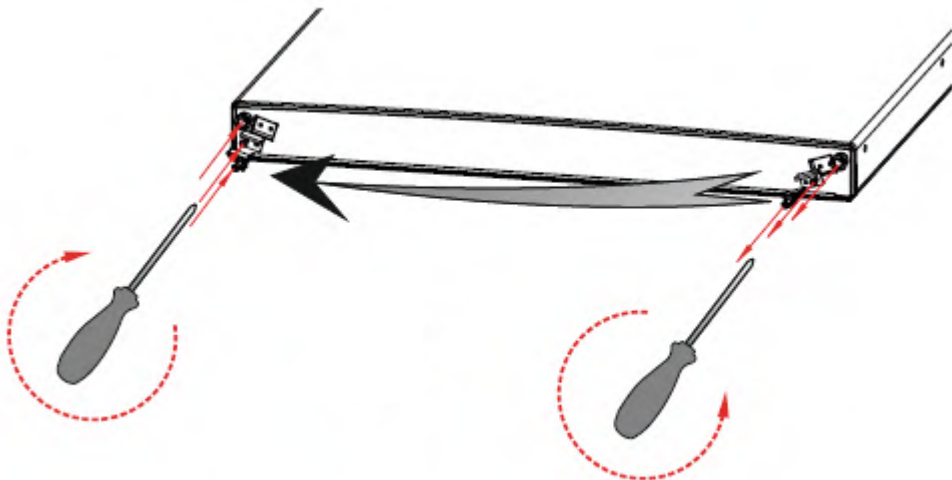

Reversing the door

Remove the middle hinge cover and then screw the screw on the side panel and assemble to the right side panel

Place the bottom door and rotate the middle hinge by 180°. After that, screw to the right side on the middle sheet.

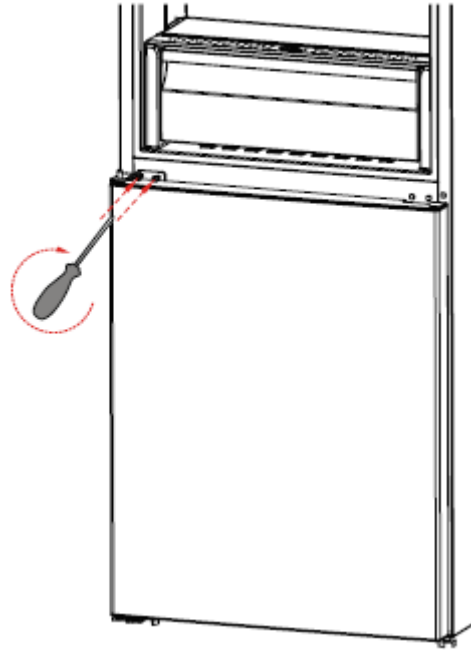
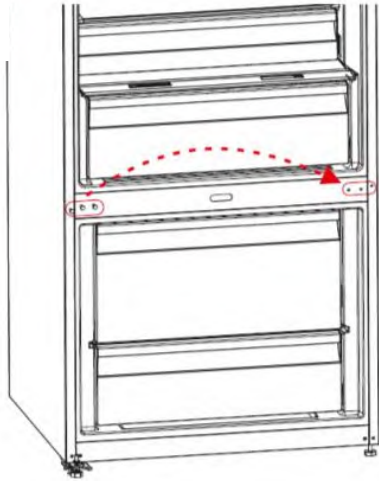

Place the top door to the middle hinge and then connect the display connector and screw the top hinge to the top panel. Place the top hinge cover.

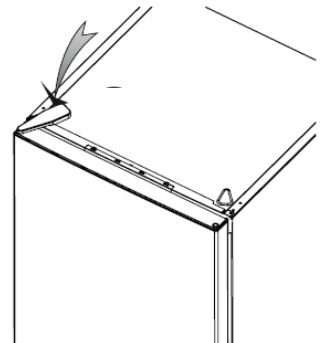
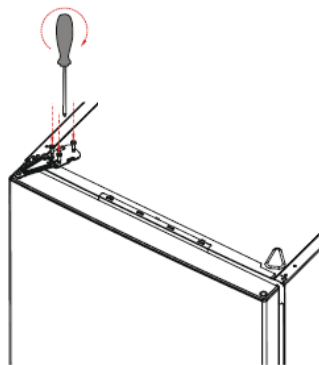
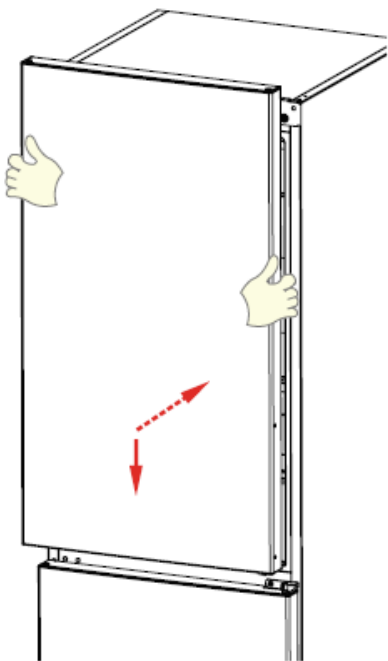

Thermostat Setting

The thermostat automatically regulates the temperature inside the cooler and freezer compartments. Refrigerator temperatures can be obtained by rotating the knob to higher numbers; 1 to 3, 1 to 5 or SF (Maximum numbers on the thermostat depends on your product.)

Important note: Do not try to rotate the knob beyond position 1, it will stop your appliance from working.

Thermostat settings:

1 – 2 : For short-term storage of food

3 – 4 : For long-term storage of food

5 : Maximum cooling position. The appliance will work longer. If required, change the temperature setting.



Replacement of LED

Screwdriver into the gap and remove the led cover.

Remove screw led

Disconnect the connector and change the led.



Replacment of Door Gasket

Pull the gasket towards starting middle of the top edge as shown. Slowly pull towards left and right corner. Then continue through frame until the gasket will completely removebe removed from door.

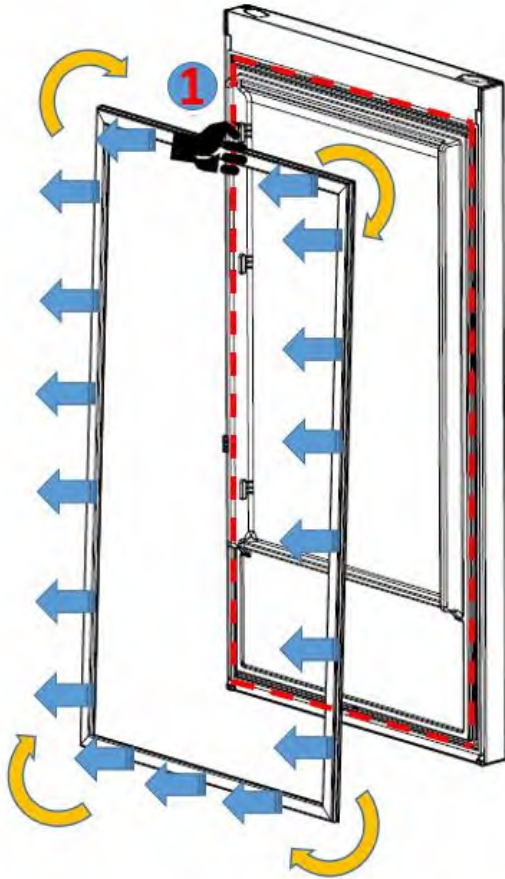

Check the replacement gasket form. Starting with upper left corner, press on the gasket until it fits to its place.. Place the other sides of the gasket with the help of your thumb as the sequence shown on picture.

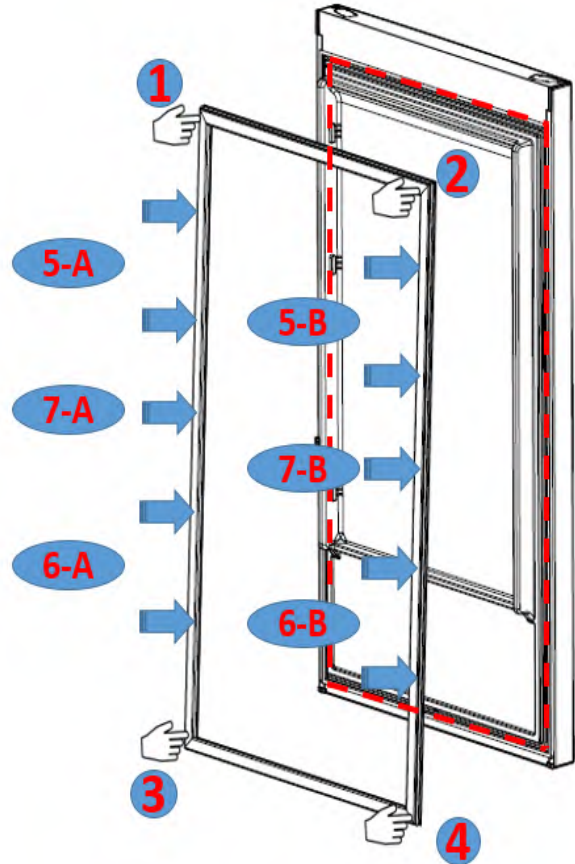

After the replacement check if there any non-fitting point on the gasket. Also check if there any opening at the gasket while the door is closed. If so that might cause condensation/icing or insufficient cooling/freezing. To prevent this soften the form of the gasket with the help of a hair dryer or hot water and make sure that all points are closing perfectly.

Replecement of Door Switch

Remove the door switch by pulling forward and disconnect switch connector.



Door switch
Door open = switch closed
Door closed = switch open



Warning: Pay attention not to damage to the door switch body details!

REFRIGERANT CYCLE DIAGRAM

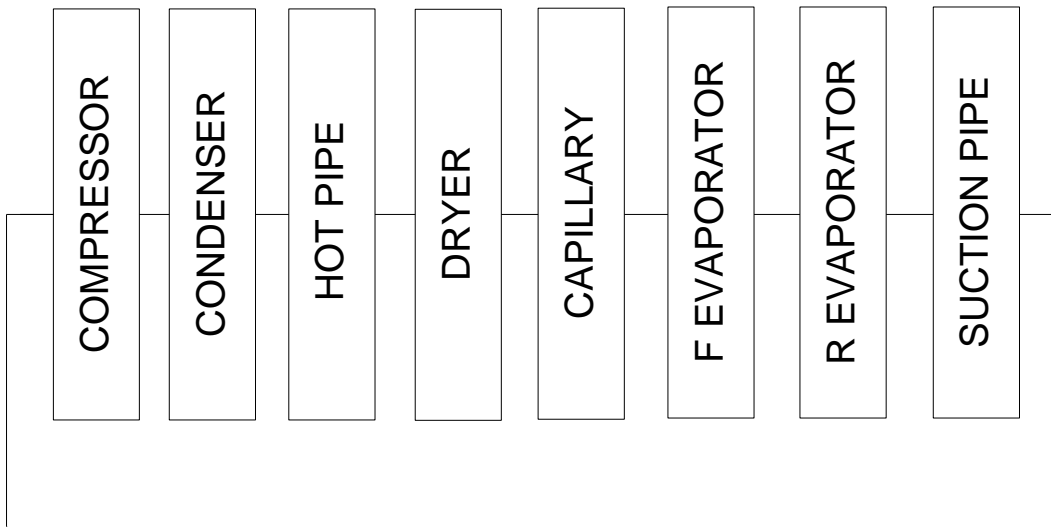
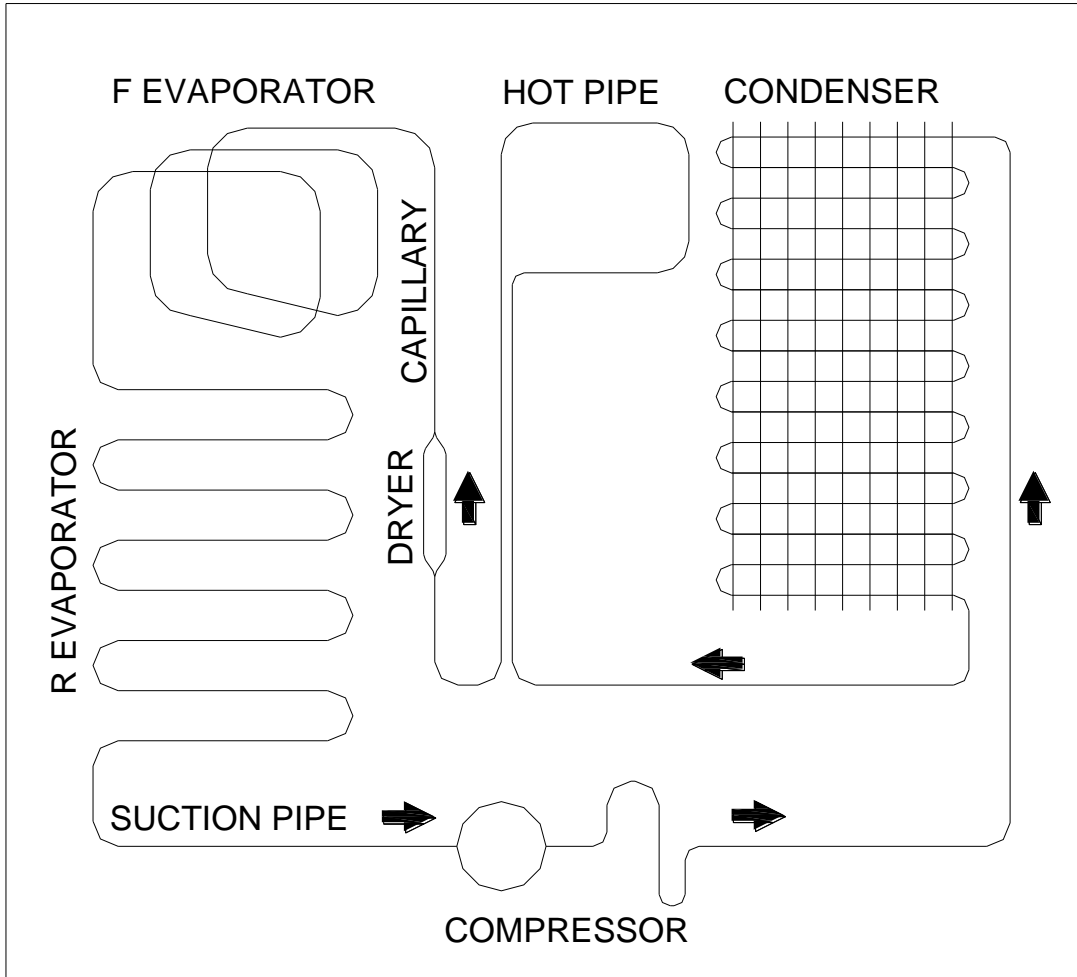



STATIC COMBI 252-266-278-286



TROUBLE-SHOOTING CHART

No/Insufficient cooling

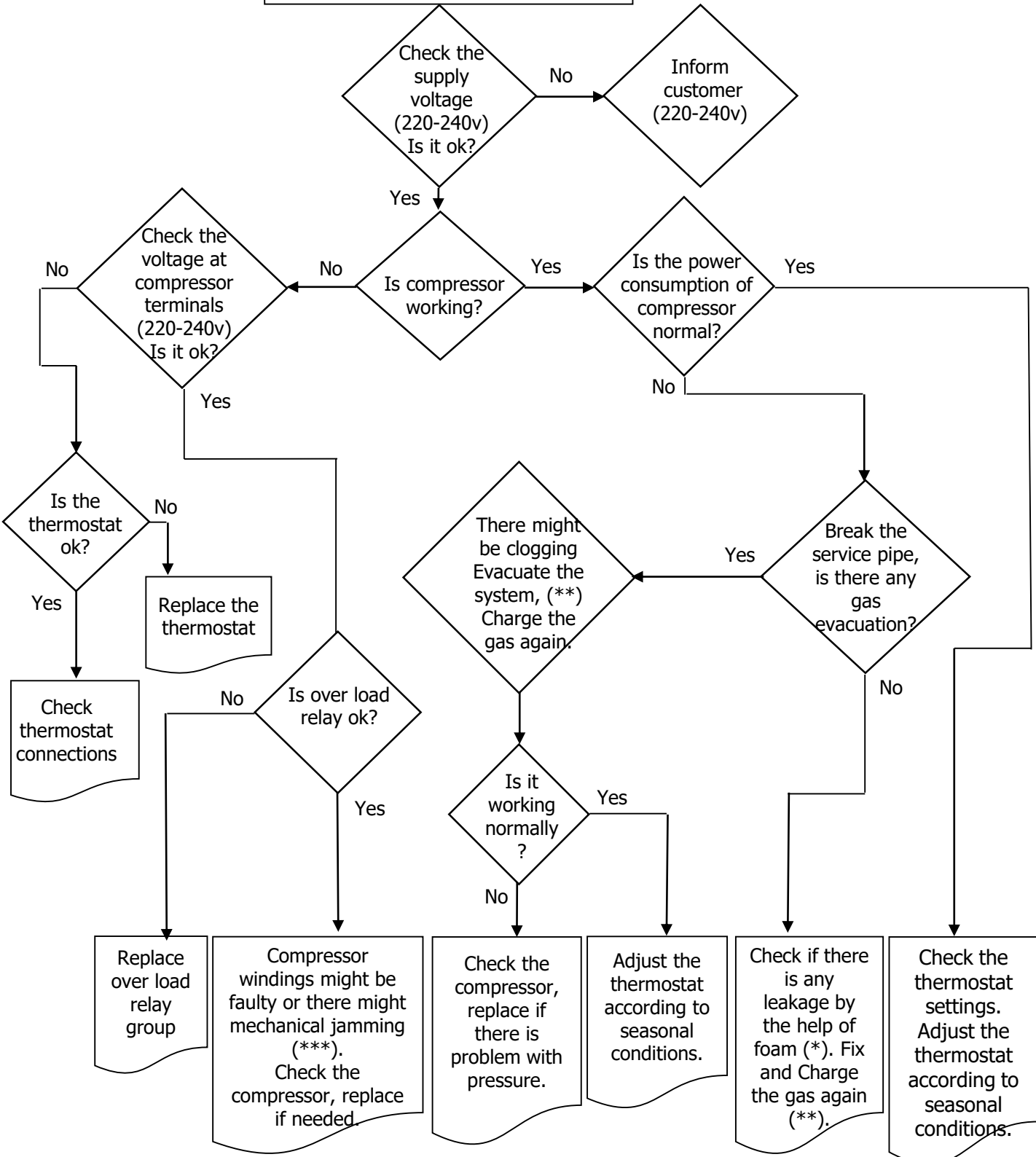

(*) Check all pipes, tubes and welding points against gas leakage. (**) Before charging gas to system, change dryer and vacuum at least 30 minutes, then charge the system with amount written on label (***) Compressor primary winding should be around 10 Ω and secondary around 15 Ω (at 25°C ambience temp.)

TROUBLE-SHOOTING CHART

Excessive Cooling

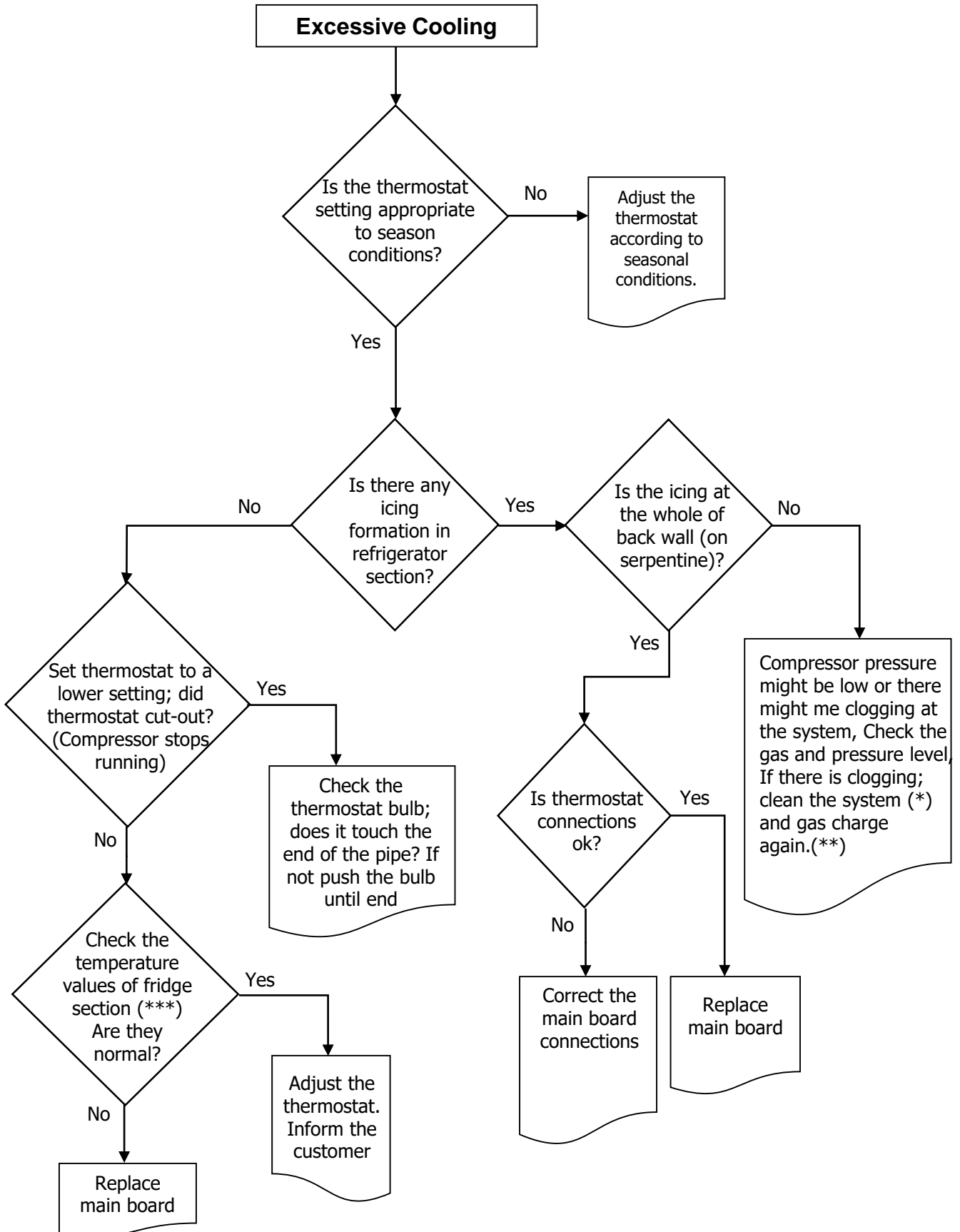

TROUBLE-SHOOTING CHART

Door/Gasket Adjustment

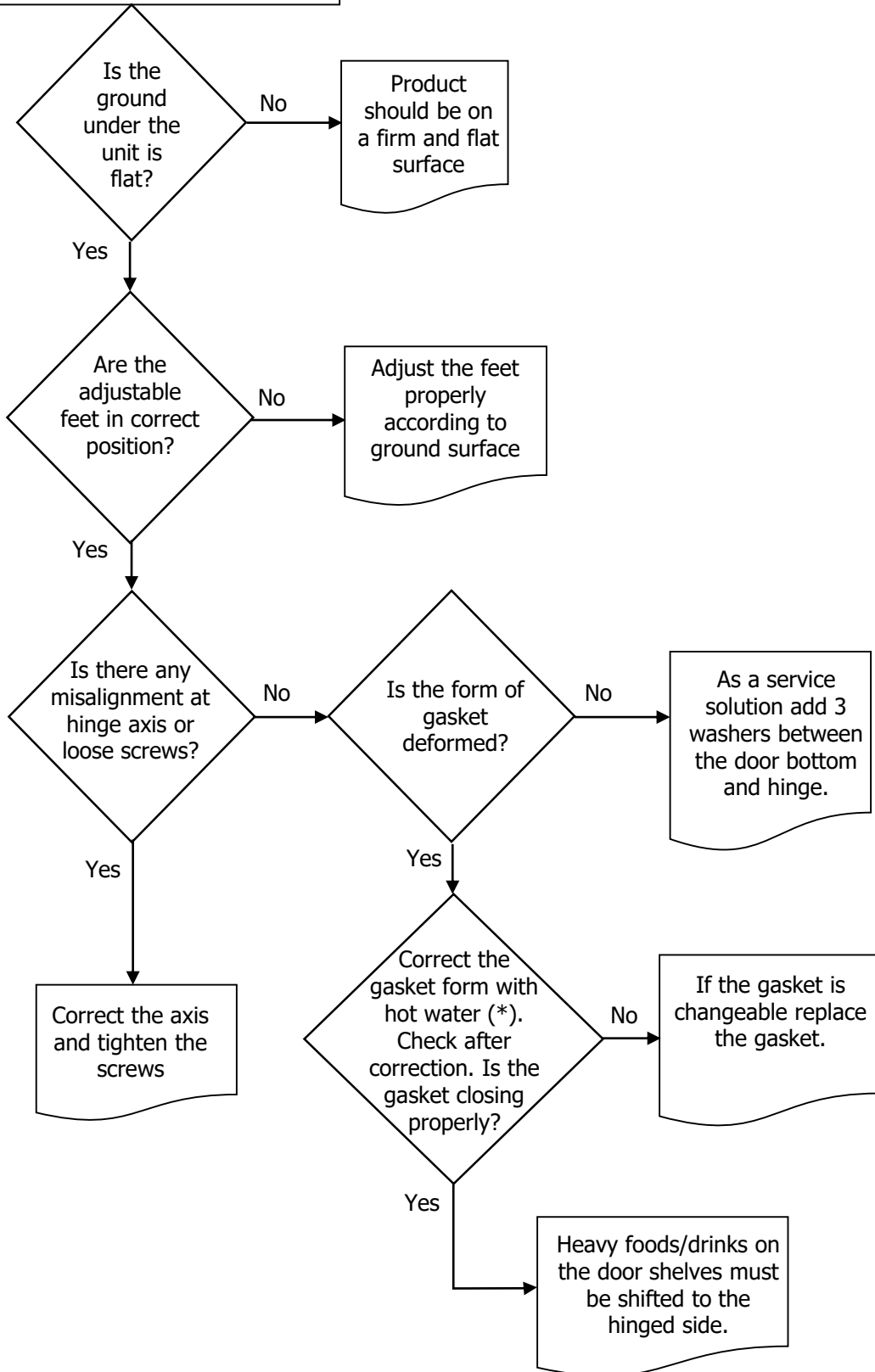

(*) Correct the gasket form by the help of hot water and hair dryer.

TROUBLE-SHOOTING CHART

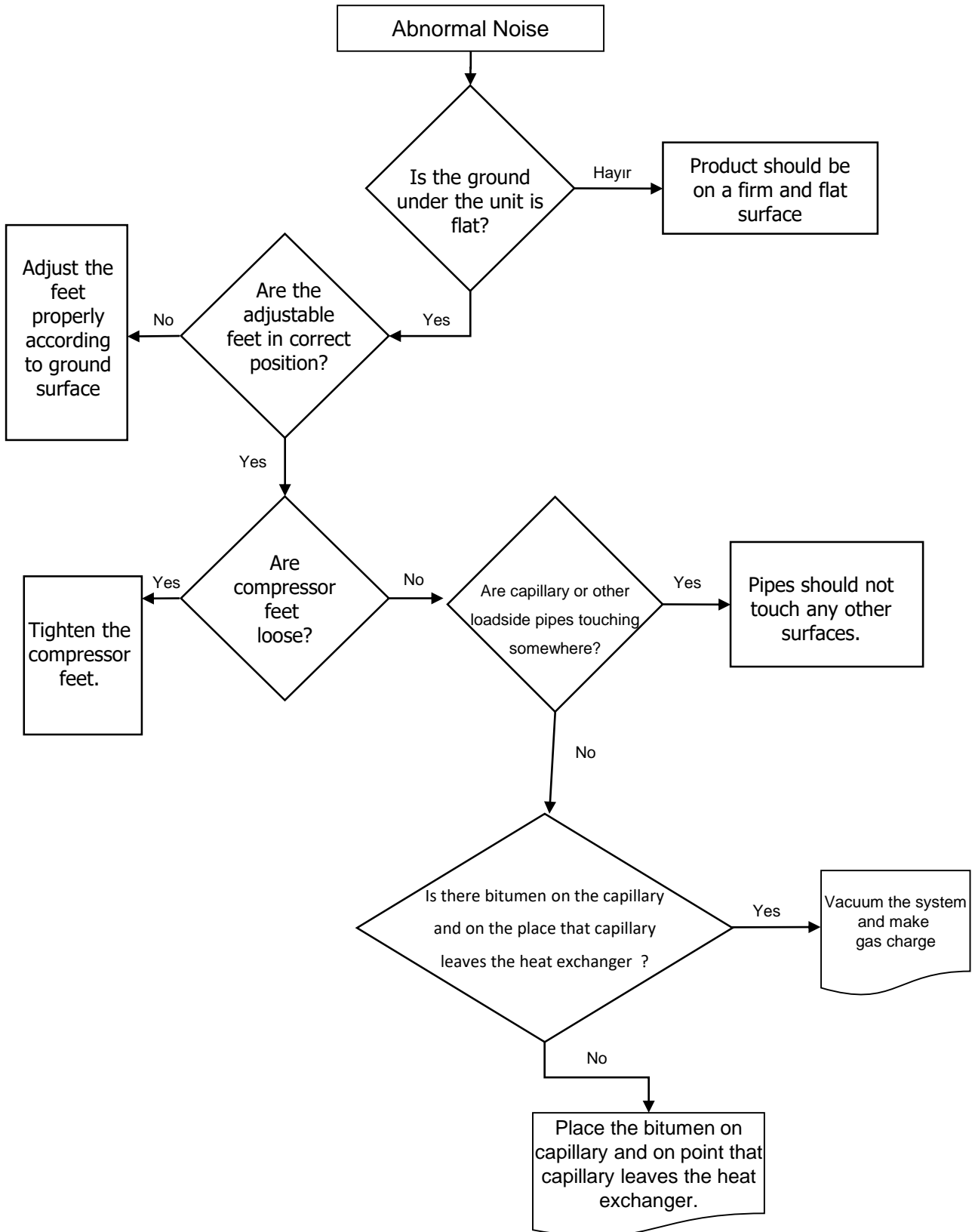



STATIC COMBI 252-266-278-286



Barcode and Serial Number Explanation:

Vestel refrigerator serial numbers are consist of 22 digits.

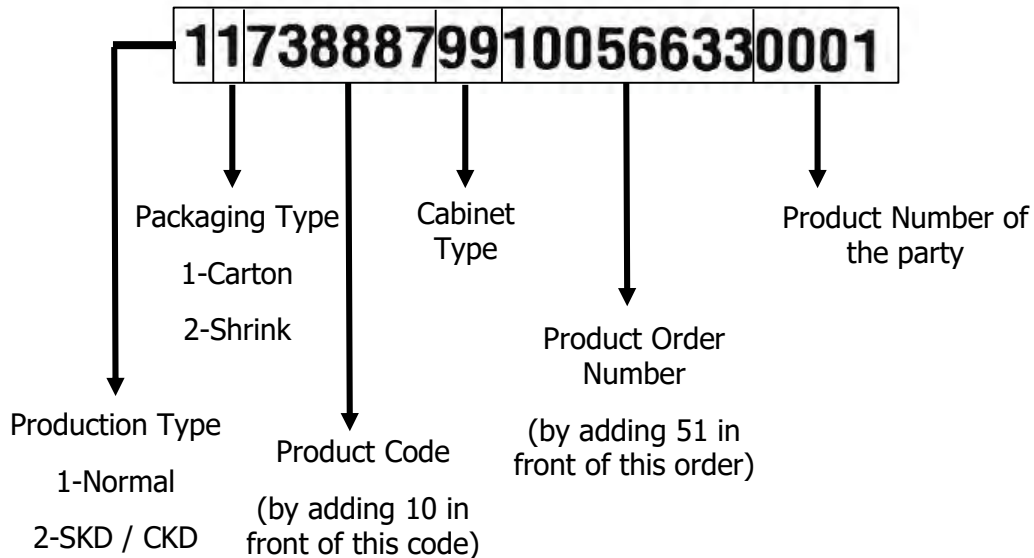
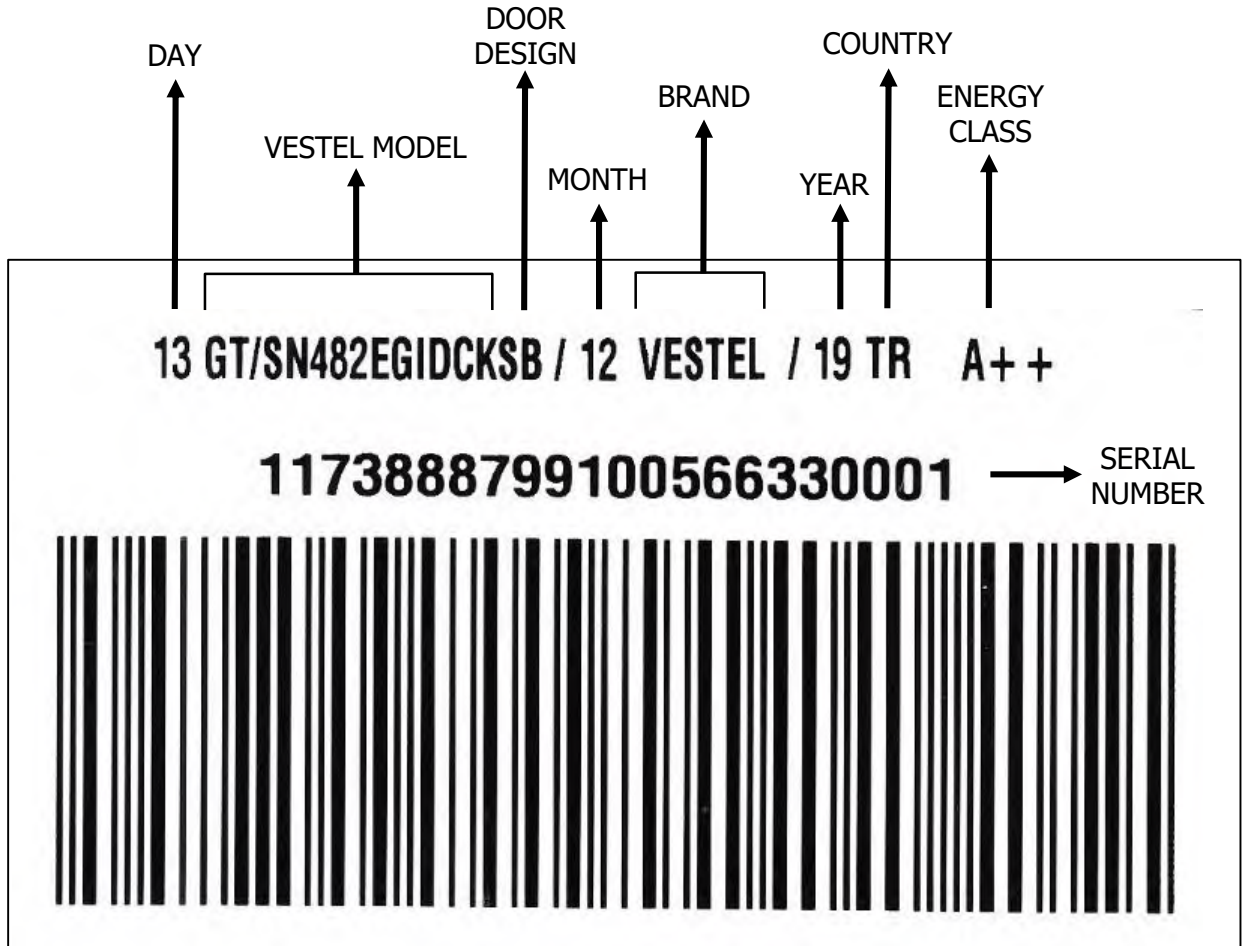

Exp:10738887