

1. It enables the setting value of freezer to be modified and super freeze mode to be activated if desired. Freezer may be set to -16, eco, -20, -22, -24 °C and Super freeze.
2. It enables the setting value of cooler to be modified and super cool mode to be activated if desired. Cooler maybe set to 8, 6, eco, 4, 2 °C and super cool.
3. It is super freeze indicator.
4. It is super cooling indicator.
5. Sr alarm indicator.

Cooler Set Button

The cooler set button allows changes to be made to the temperature of the cooler compartment. Super cool and eco mode can also be activated using this button.

Freezer Set Button

The freezer set button allows changes to be made to the temperature of the freezer compartment. Super freezer and eco mode can also be activated using this button.

Sr Alarm

Sr alarm will change to red if any problems occur.



NF COMBI – 462 ELECTRONIC - FDUO



Control Panel

Super Cool Mode

When would it be used?

- To cooling huge quantities of food.
- To cooling fast food.
- To cooling food quickly.
- To store seasonal food for a long time.

Activating Super Cool Mode

Push the cooler set button until the super cool symbol illuminates. The buzzer will sound twice and the mode will be set.

During Super Cool Mode

Super cool mode can be cancelled in the same way it is selected.

Super Freeze Mode

When would it be used?

- To freeze a large quantity of food that cannot fit on the fast freeze shelf.
- To freeze prepared foods.
- To freeze fresh food quickly to retain freshness.

Activating Super Freeze Mode

Push the freezer set button until the super freez symbol illuminates. The buzzer will sound twice and the mode will be set.

During Super Freeze Mode

Super freez mode can be cancelled in the same way it is selected.

Activating Economy Mode

Cooler compartment

- Press the cooler set button until the economy symbol illuminates.
- If no button is pressed for 1 second the mode will be set and the buzzer will sound twice as confirmaiton.
- To cancel, press the cooler set button.

Freezer compartment

- Press the freezer set button until the economy symbol illuminates.
- If no button is pressed for 1 second the mode will be set and the buzzer will sound twice as confirmaiton.
- To cancel, press the freezer set button.



NF COMBI – 462 ELECTRONIC - FDUO



Control Panel

Screen Saver Mode

Purpose

This mode saves energy by switching off all control panel lighting when the panel is left inactive.

How to Use

- Screen saver mode will be activated automatically after 30 seconds.
- If you press any key while the lighting of the control panel is off, the current machine settings will reappear on the display to let you make any change you wish.
- If you do not cancel the screen saving mode or press any key for 30 seconds, control panel will remain off.

To deactivate the screen saving mode,

- To cancel the screen saving mode, first of all, you need to press any key to activate the keys and then press and hold the freezer set button for 5 seconds.
- To reactivate screen saving mode, press and hold the freezer set button for 5 seconds.

Cooler Temperature Settings

- Press the cooler set button once.
- When you first press the button, the previous value will appear on the setting indicator of the cooler.
- Whenever you press this button, a lower temperature will be set (+8 °C, +6 °C, eco, +4 °C, +2 °C, or super cool).
- If you press the cooler set button until the super cool symbol appears on the cooler setting indicator, and do not press any buttons for 3 second, super cool will flash.
- If you continue to press the same button, it will restart from +8 °C.

Freezer Temperature Settings

- Press the freezer set button once.
- When you first press the button, the previous value will appear on the setting indicator of the freezer.
- Whenever you press this button, a lower temperature will be set (-16 °C, eco, -20 °C, -22 °C, -24 °C, or super freez).
- If you press the freezer set button until the super freez symbol appears on the freezer setting indicator, and do not press any buttons for 3 second, super freezer will flash.
- If you continue to press the same button, it will restart from -16 °C.

Door Open Alarm Function

If fridge door is opened more than 2 minutes, appliance sounds 'beep beep'.

Air Flow Diagram

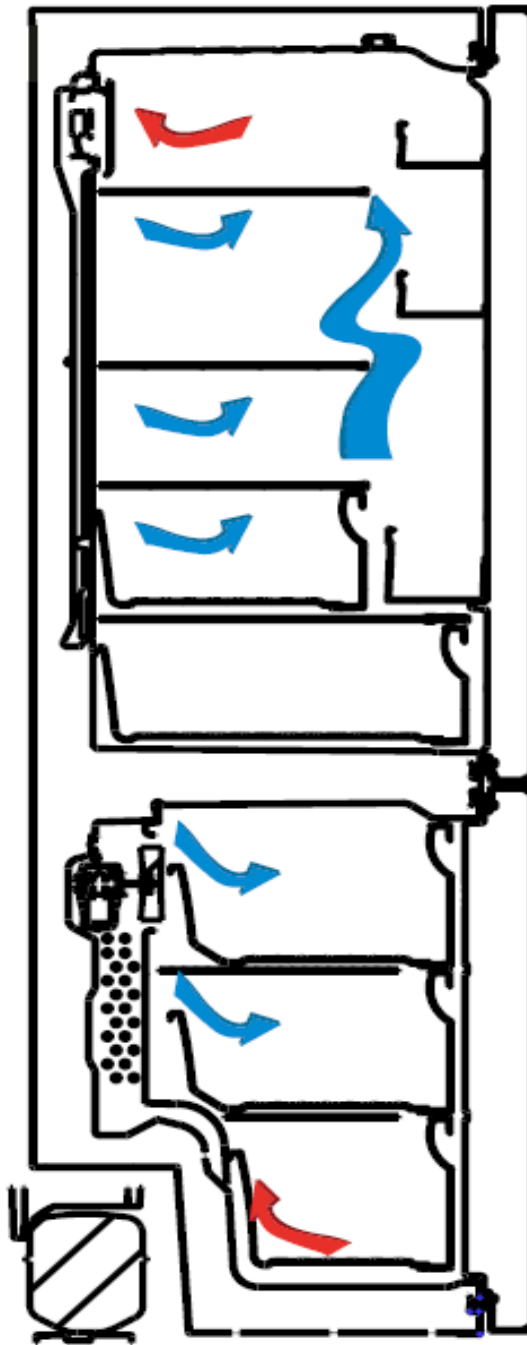

 Cold Air
 Returning warm air

Refrigerant Cycle Diagram

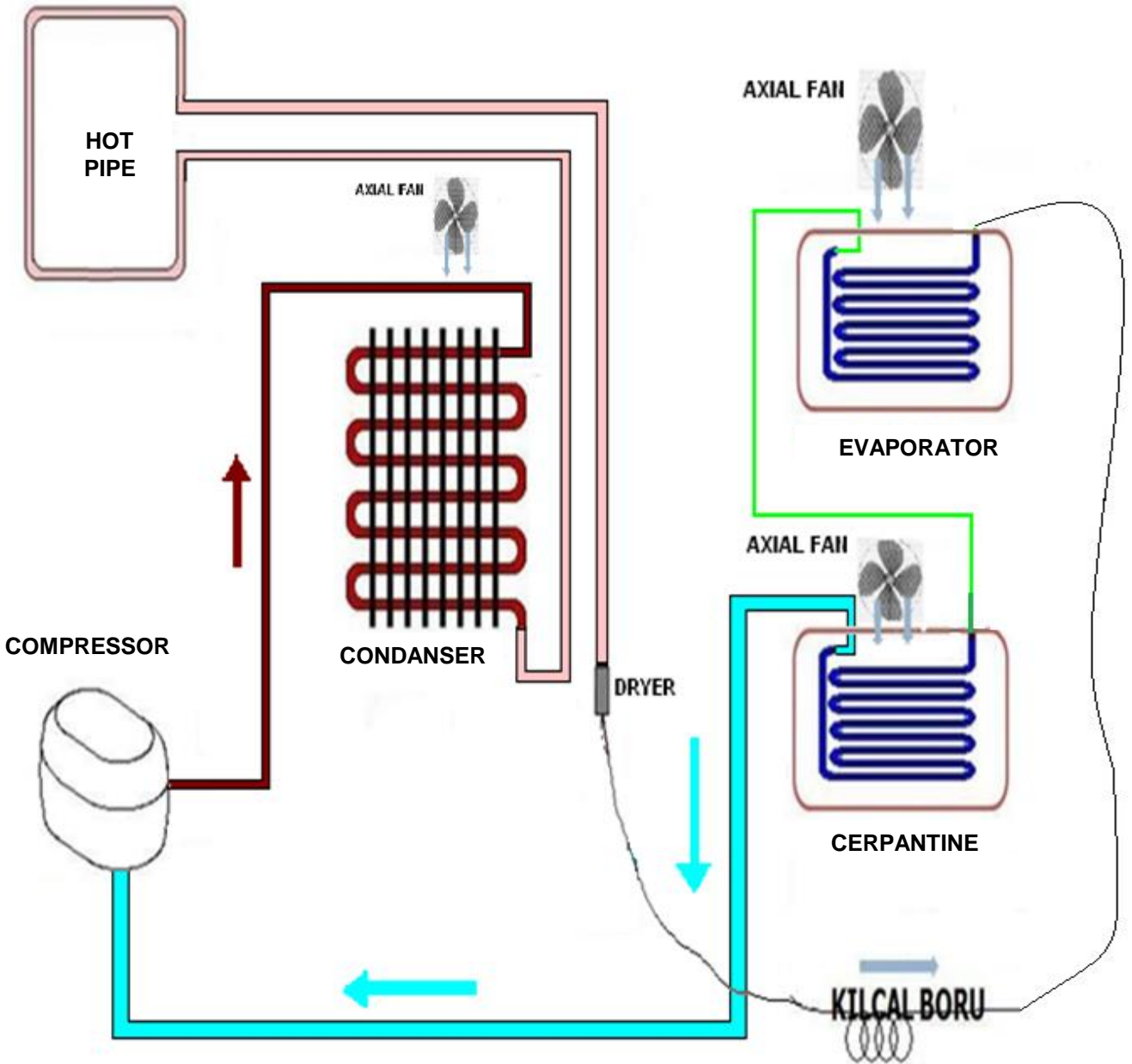

Resistance Values According To The Temperature Sensor (°C/Ohm Rates)

(For The Freezer Defrost and The Cooler Ambient Sensor)

45 °C/1kΩ	-1 °C/6.2kΩ
35 °C/1.5kΩ	-3 °C/6.8kΩ
30 °C/1.8kΩ	-5 °C/7.5kΩ
25 °C/2.2kΩ	-7 °C/8.2kΩ
19 °C/2.7kΩ	-12 °C/10kΩ
14 °C/3.3kΩ	-15 °C/12kΩ
10 °C/3.9kΩ	-20 °C/15kΩ
5.5 °C/4.7kΩ	-24 °C/18kΩ
1.5 °C/5.6kΩ	-31.5 °C/27kΩ
0 °C/6kΩ	-35.5 °C/33kΩ

Sensor Resistance Values According To The Temperature (°C/Ohm Rates)

(For The Cooler Defrost Sensor)

45 °C/2.15kΩ	-1 °C/17.1kΩ
35 °C/3.26kΩ	-3 °C/19kΩ
30 °C/4.02k6Ω	-5 °C/21.1kΩ
25 °C/5kΩ	-7 °C/23.5kΩ
19 °C/6.53kΩ	-12 °C/30.8kΩ
14 °C/8.23kΩ	-15 °C/36.5kΩ
10 °C/9.95kΩ	-20 °C/48.6kΩ
5.5 °C/12.3kΩ	-24 °C/61.5kΩ
1.5 °C/15kΩ	-31.5 °C/98kΩ
0 °C/16.3kΩ	-35.5 °C/12.6kΩ

When the refrigerator works on first time;

If the cooler compartment defrost sensor and the freezer compartment defrost sensor are hotter than -5°C , the test system works automatically. These below components are tested automatically every 5 seconds.

- ❖ The compressor starts and stops after 5 seconds.
- ❖ The defrost resistance starts and stops after 5 seconds.
- ❖ The balance resistance starts and stops after 5 seconds.
- ❖ The DC Radial Fan starts and stops after 5 seconds.
- ❖ The freezer fan starts and stops after 5 seconds.

After these steps, the system waits 5 minutes and then it will switch normal mod.

Freezer Defrost Program

- According to the conditions of usage, the defrost might be activated after the min compressor running time; 8 hours or max total time; 55 hours. Below matters are also effected;
- Consisted ice amount,
- Door open-close,
- Sudden usage variance,
- Cooler sudden temperature rise,

Cooler Defrost Program

The cooler defrost and the freezer defrost are operated parallel except those below. If the cooler defrost sensor does not feel 5°C three times during a particular period of time.

- Defrost will be activated after the refrigerator works max 9 hours. According to the conditions of usage, the defrost might be activated (due to mentioned those below) after the compressor works min 5 hours.
- Consisted ice amount,
- Door open-close,
- Sudden usage variance,
- Cooler sudden temperature rise,

Freezer Defrosting Time

The Defrost is disabled when the defrost sensor temperature feels 8°C .

If defrost time passes 37 minutes, defrost completing temperature will be rise to 15°C .

Cooler Defrosting Time

The cooler defrost and the freezer defrost are operated parallel except those below. The cooler defrost will not work if the freezer defrost stops.

The defrost process stops when the defrost sensor temperature feels 7°C. At the low ambient temperature or when the compressor stops; to balance, defrost stops when the defrost sensor temperature feels 15°C. But if the defrost time or the compressor stopping time goes over 6 hours, the resistance will be stopped.

Compressor delay: First, the defrost process ends, the system waits 5 minutes, just after that the compressor is active.

In Case of Power Cut

- All regulated parameters and functions are kept in memory when the power cut.
- When the electricity comes, if the defrost sensor temperature is lower than -5 °C the compressor works 5 minutes later. If it is higher than -5 °C.

Low Voltage Program

In case of supply voltage lower than 170 V for more than 5 seconds, the low voltage program will stop the compressor, evaporator fan motor, condenser fan motor and also the super freezing super cooling functions. If this situation happens during the defrost mode, then the appliance will stop during defrosting.

When the supply voltage reaches a value greater than 180V, the appliance will start again from the defrost mode.

If the appliance was not stopped during the defrost mode, then will be stopped for minutes more for compressor secure start-up and will be started from the last setted program.

Other Features

Warnings : The door open warning is active 2 minutes later and it alarms.

Door Direction : It is possible to reverse the door.

Gasket : It is possible to change the gasket.

Probable Faults

Unsufficient cooling	Is the appliance too close to wall or heat sources (stove, central heating, oven, cooker etc.)?	It should be placed min 50cm distance from heat sources and min 5 cm from electrical ovens.
	Is the ambient temperature high?	Raise the thermostat value.
	Check whether putting the hot foods in the refrigerator?	Put the foods after get cold.
	Is there any gas leakage in refrigerant system?	Check all welding points in the system.
The foods in the cooler compartment are freezing.	Were the foods placed close to cooling air outlet?	Please do not block air outlets
	Is the cooler thermostat value high ? Is there any hot foods close to the cooler sensor?	Decrease the cooler thermostat value and do not put hot things close to the sensor.
Are there any sweating or icing?	Were the liquid foods in the closed containers?	Put the liquid foods into the closed containers.
	Were the hot foods put into the refrigerator?	Put it into after getting cold.
	Was the refrigerator door opened?	Do not leave the refrigerator door open and do not often open or close.
Abnormal Noise	Is the appliance on the flat surface?	The floor should be straight and balance the refrigerator with the help of the adjustable feet.
	Is the compressor feet loose	Fix it.
	Is the condenser or fan stationary normal?	Fix it.
	Do the capillary tube or all other tubes touch any where?	Fix it.



NF COMBI – 462 ELECTRONIC - FDUO



Service Mode

Entering service mode :

- Select «8» set value then press the cooler set button 10 seconds.
- If there is a faulty situation, error code will be observed on screen. Otherwise nothing will be on the screen.
- Buzzer will sound beep for 0.1 sec. each 5 sec. during service mode.
- SR icon will light continuously.
- Service function could be activated by pushing «Cooler Set» button

SERVICE FUNCTION	
PUSHING COOLER SET BUTTON ONE TIME.	STARTING MODE
	«8» value will select.
	STARTING LIST “-16” drain heater “eco” DC Radial Fan motor “-20” Refrigerator Defrost Heater (RDS) “-22” Ionizer / UPT “-24” R&Su heater “8” Middle Bracket heater “6” Evap Defrost heater “5” Evap fan motor “4” Condenser fan motor “2” Compressor
	The number of components which is controlled is shown on display. Icon goes off when the starting test finishes and then display returns to service mode.
PUSHING COOLER SET BUTTON TWO TIMES.	MANUAL DEFROST
	«6» value will select.
	Defrost mode is started after third step. Defrost might be finished manually or automatically.
	Defrost might be finished manually by using the cooling set button. Icon goes off and display returns to service mode.
	Automatic defrost operates according to the standard defrost time.



NF COMBI – 462 ELECTRONIC - FDUO



User and Service Mode Error Message

To cancel Service Mode : You can use same method as entering the Service Mode.

DEFECT TYPE	SERVICE MODE REACTION
FREEZER SENSOR OPEN/SHORT CIRCUIT	8 Led will light
COOLER SENSOR OPEN/SHORT CIRCUIT	6 Led will light
DEFROST SENSOR OPEN/SHORT CIRCUIT	5 Led will light
AMBIENT SENSOR OPEN/SHORT CIRCUIT	4 Led will light
RDS SENSOR OPEN/SHORT CIRCUIT	2 Led will light
COMRPESSOR DEFECT	-24 Led will light
DEFROST HEATER DEFECT	-22 Led will light
LOW COOL	-18 Led will light
HIGH COOL	-16 Led will light
LOW FREEZE	-20 Led will light

Changing The Door Swing Direction to Right Hand

1. Hold the top hinge cover and remove it toward that direction (Pic-1)

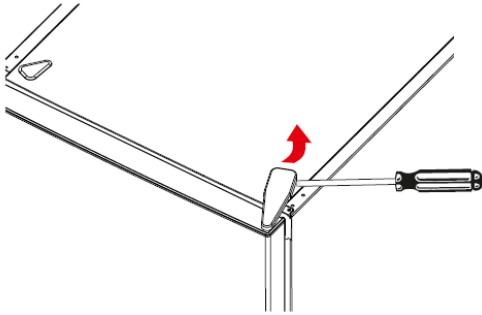

Picture-1

2. Disconnect the display connector. Unscrew the screws fixing the top hinge and remove it. (Pic-2)

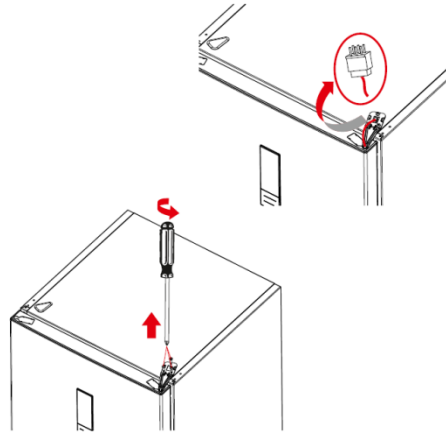

Picture-2

3. Displace the top door (Pic-3)

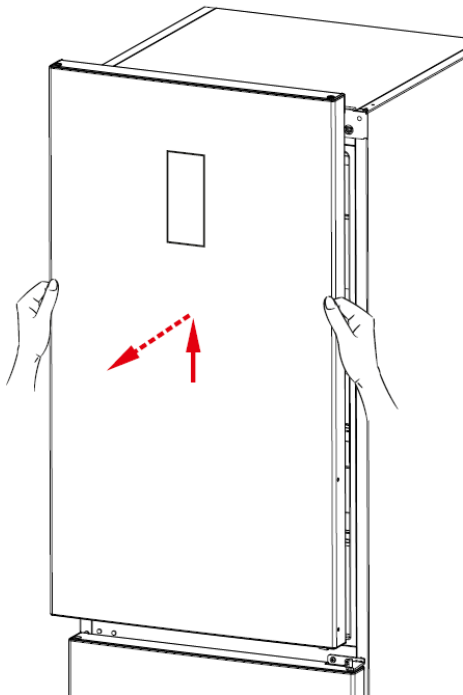

Picture-3

4. Unscrew the two screws fixing the middle hinge and remove it. (Pic-4)

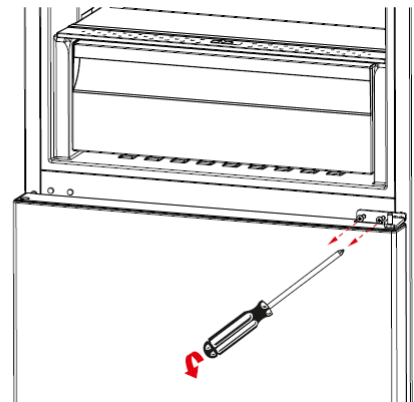

Picture-4

5. Displace the bottom door. (Pic-5)

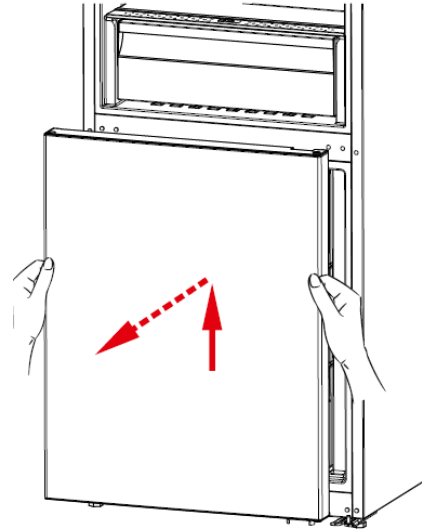

Picture-5

6. Unscrew the adjustable foot and unscrew the bottom hinge screws (Pic-6)

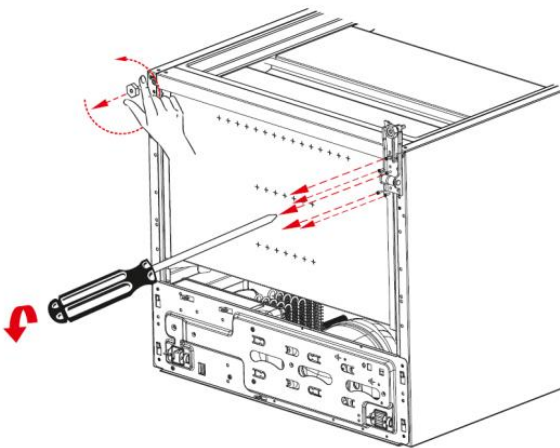

Picture-6

7. Unscrew the bottom hinge pin and screw it to other hole. (Pic-7)

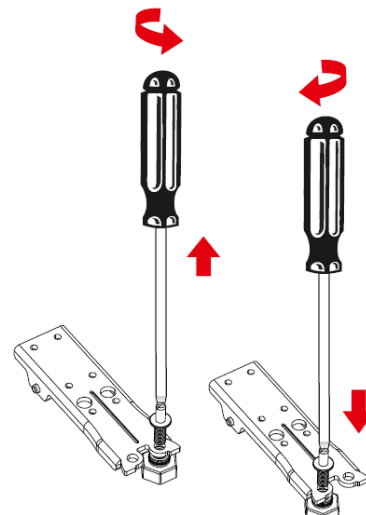

Picture-7

8. Screw the bottom hinge to the left bottom side of refrigerator. Screw the adjustable foot there. (Pic-8)

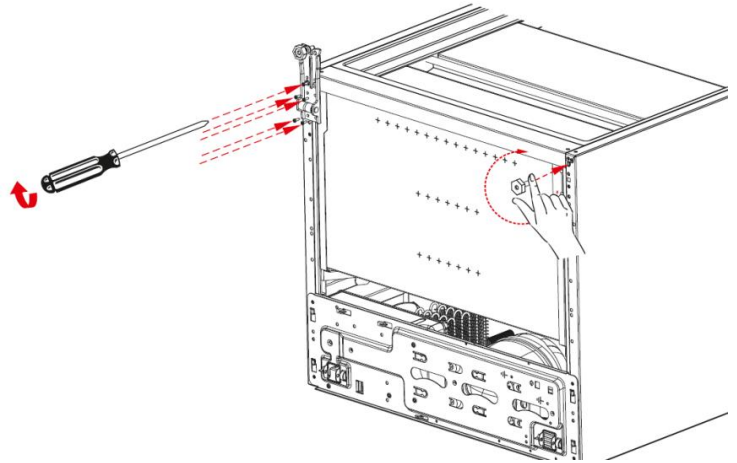

Picture-8

9. Replace the top bushing and the top bushing cap at the bottom door. (Pic-9)

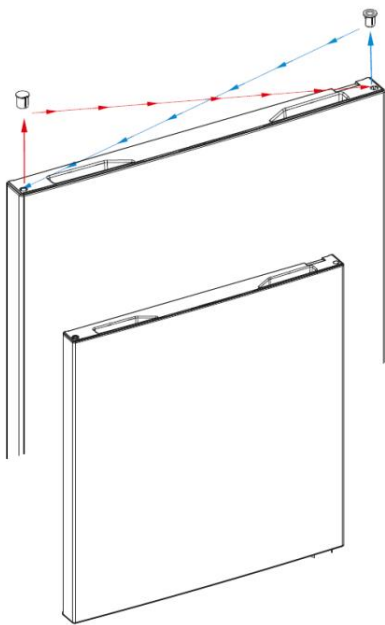

Picture-9

10. Unscrew the two screws fixing stopper and stopper support plate under the bottom door. After that screw the other side. (Pic-10)

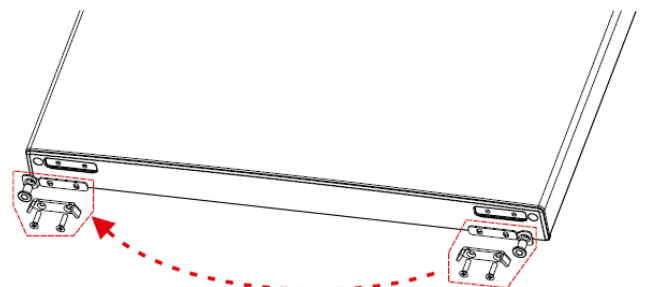

Picture-10

11. Remove the support plastic under the upper door. Then re screw these parts to the other side symmetrically. (Pic-11)

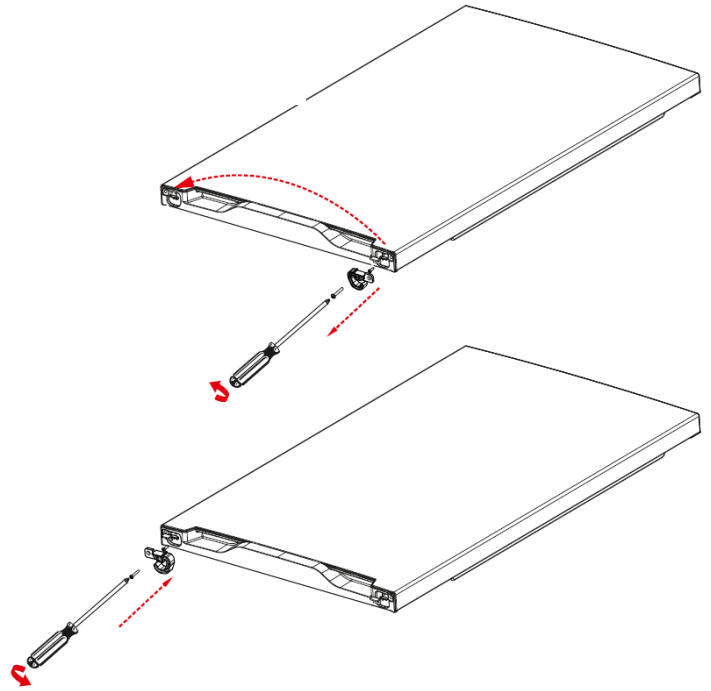

Picture-11

12. Remove the socket cover-right of the top door. Remove the display socket. Please use the socket cover to hidden other housing (Pic-12)

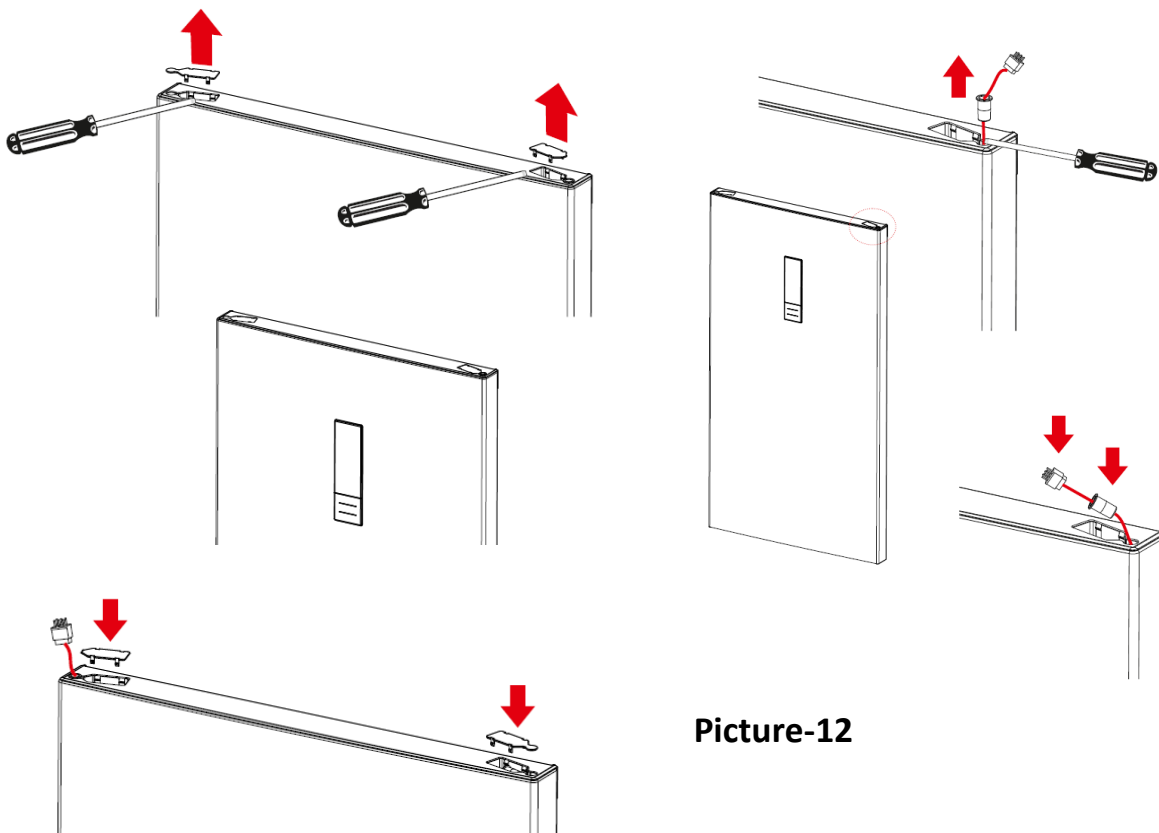

Picture-12

13. Remove the middle hinge cover and then screw the screw on the side panel and assemble to the right side panel (Pic-13)

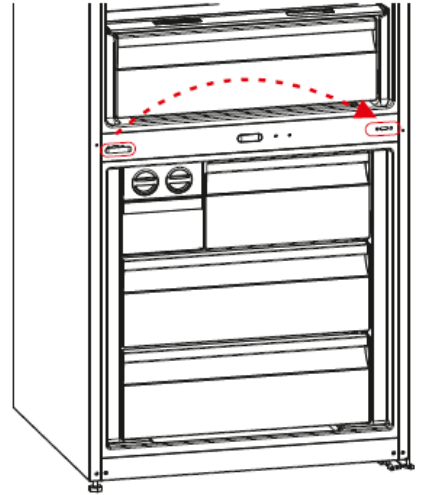

Picture-13

14. Place the bottom door and rotate the middle hinge by 180°. After that, screw to the right side on the middle sheet. (Pic-14)

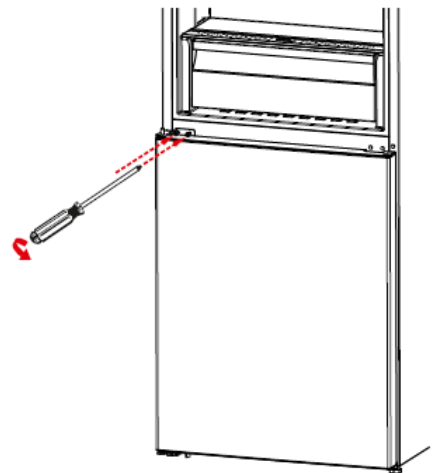

Picture-14

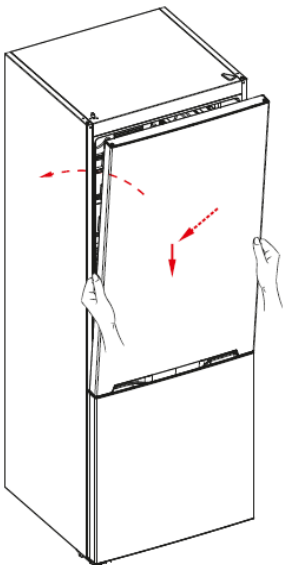

Picture-15

15. Place the top door to the middle hinge and then connect the display connector and screw the top hinge to the top panel. Place the top hinge cover. (Pic-15)

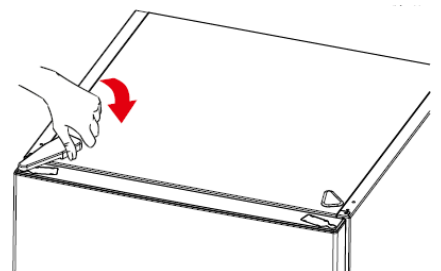
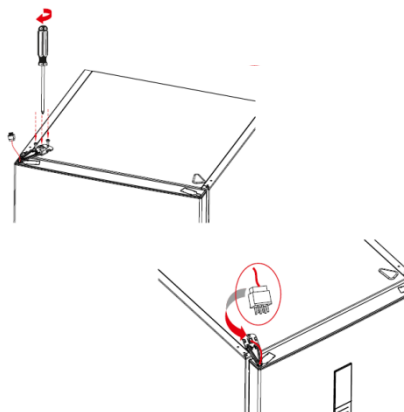

CAUTION: The plug must be pulled out before the mainboard group is removed.

1. Unscrew the screws which are fixing the main board cover. (Pic-1 / Pic-2)



Picture-1



Picture-2

2. Pull the mainboard slightly forward and disconnect all the connectors and then replace it. Finally, place the mainboard cover and screw it. (Pic-3 / Pic-4)



Picture-3

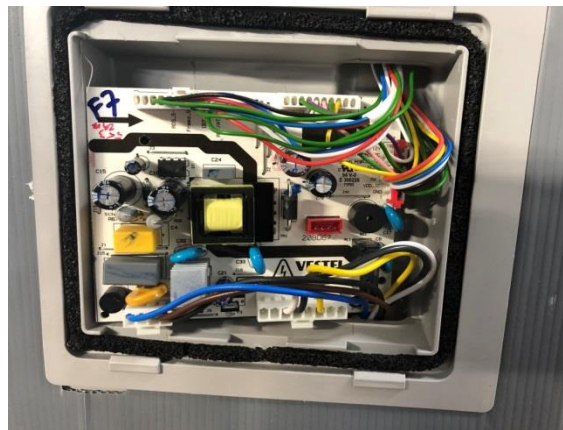

Picture-4

1- First remove the glass shelves and chiller shelf (Pic-1)



Picture-1

2- Remove refrigerator multi-flow caps and unscrew the screws. (Pic-4)



Picture-2

3- Flex the multi flow by holding the fan cover and remove it. Disconnect the connector after removing the multi flow. (Pic-3)



Picture-3

1. Remove the fan cover by flexing the fan cover detail and then remove the fan motor by flexing the fan motor rubbers. (Pic-1/ Pic-2/Pic-3)



Picture-1



Picture-2



Picture-3

2. Place the rubbers to the fan motor. After that, first place the bottom two details of the fan motor and place the top two details by pressing-flexing it. (Pic-4/ Pic-5/Pic-6)

Note : *The fan motor cable outlet should be at the top-left corner of it.*

3. After the connector is connected, place it by flexing it and then reassemble the multi flow by screwing.



Picture-4



Picture-5



Picture-6

Side Led Version

1. Stick a tape to protect plastic. Insert a flat screwdriver into the gap and remove the cover. (Pic-1)



Picture-1

2. Remove the led strip light from its housing. (Pic-2)



Picture-2

3. Disconnect the connector and change the led light strip. (Pic-3)

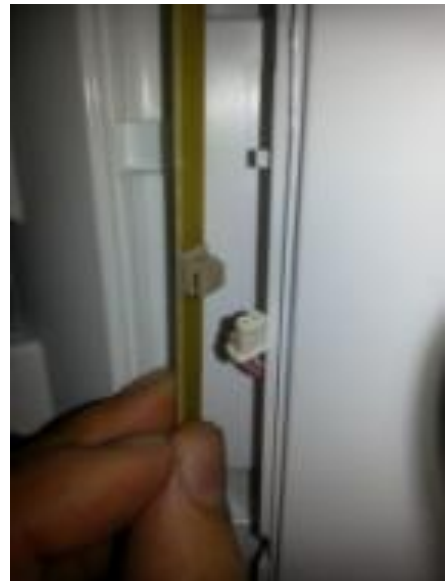

Picture-3

4. First, place the bottom point of the led light strip and then place towards other side.(Pic-4)



Picture-4

5. Reassemble the led cover. (Pic-5)



Picture-5

Top Led Version

Remove the led cover by pulling forward and disconnect the connector.

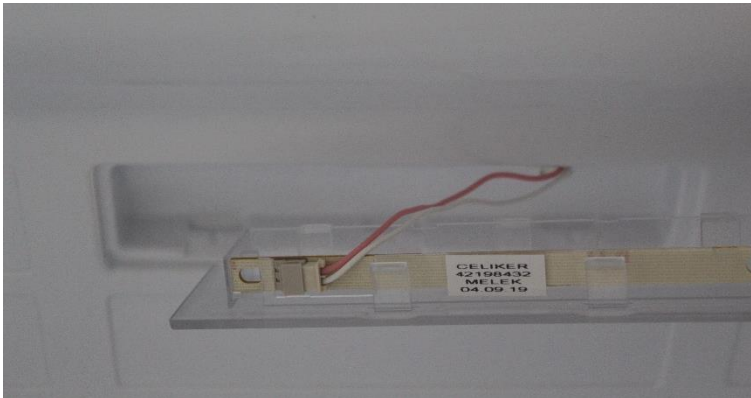

Remove the sensor cover by pulling forward and disconnect sensor connector.

Refrigerator Sensor



Picture-1



Picture-2



Picture-3

Freezer Sensor

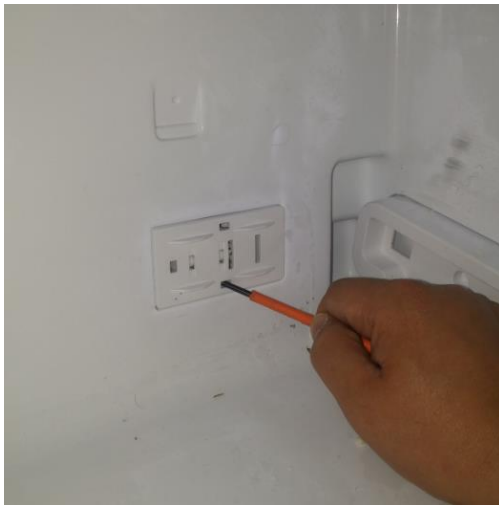

Picture-1



Picture-2

CAUTION: Pay attention not to damage to the sensor cover details!

1. Remove the freezer baskets, freezer glass shelves and icematic (Pic-1 / Pic-2)



Picture-1



Picture-2

2. Unscrew the screw fixing the multiflow group. (Pic-3)

3. Removing the freezer bottom cover by flexing back side of it. (Pic-4)



Picture-3



Picture-4

Replacement of Fin Evaporator Assy

1. Disconnect to evaporator connector.
(blue connector) (Pic-1)

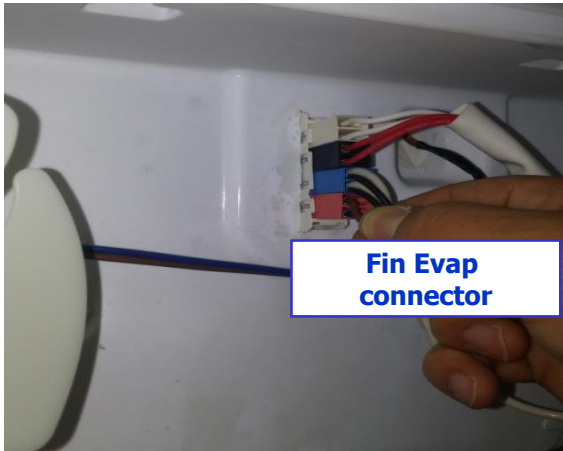

Picture-1

2. Remove the evaporator by pulling forward in a horizontal direction. (Pic-2)



Picture-2

Do not push it up or down. You may broke the fixing plastics.

Removing The Thermal Fuse

1. Remove the thermal fuse connector.
(Pic-1) (black-white connector)

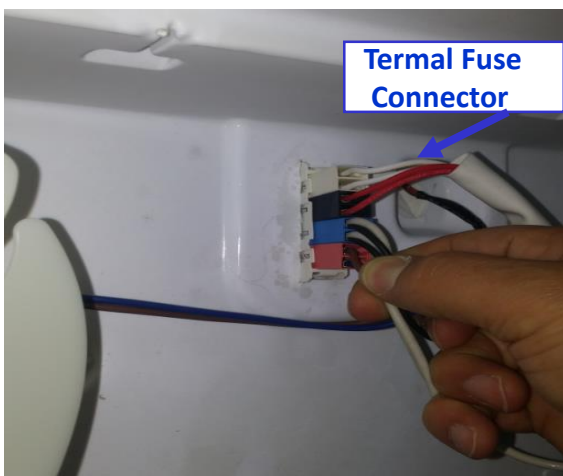

Picture-1

2. Thermal fuse has two details. These details hold on to the pipe. It could be removed easily.(Pic-2)



Picture-2

Removing Fin Evaporator Sensor

Displace the defrost sensor from its location. Cut the end of the sensor cable by using pliers/side cutting pliers.

Connect the cut sensor cable ends to each other as separate clips.

Immobilize the sensor resistance's end its previous position by using cable bant.

In order to prevent oxidation on the metal end of clips. You can use paste which is founded in kit.

Excessive part of the cable should not be left scattered in order not entanglement on the fan motor. It should be fixed with a separate cable bant.

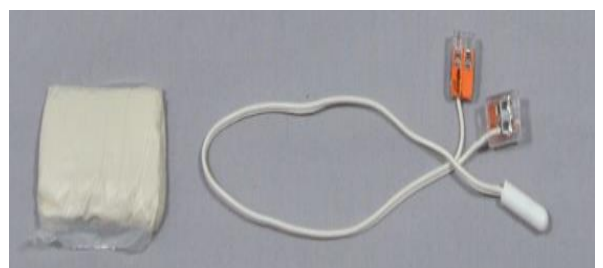
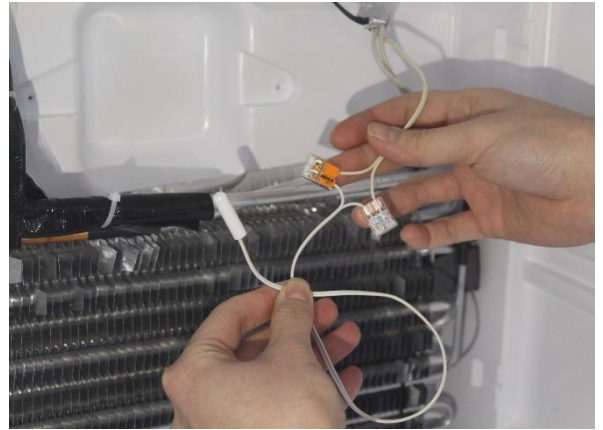
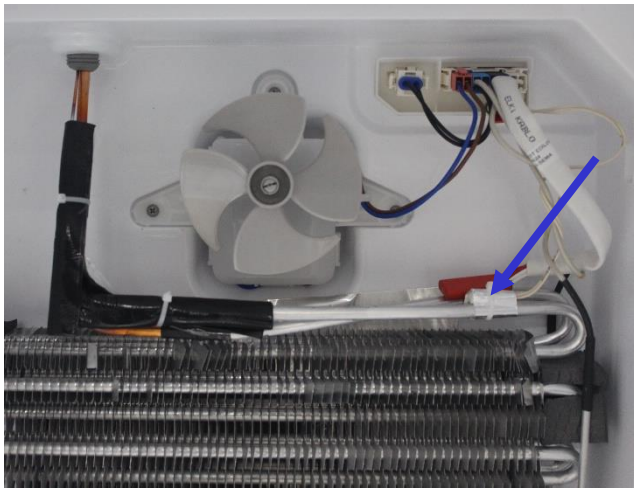

32030727 - SENSOR SERVICE KIT

Removing/Assembling The Reed Switch

Take the reed switch out of its place with a screwdriver. Then Disconnect the connectors of the Switch and remove it.

NOTE: Reed Switch is a very sensitive miniature electronic card. So during the assembly and disassembly be carefull not to damage it.



Removing/Assembling The Reed Switch

Stick a tape to protect plastic. Insert a flat screwdriver into the gap and remove the reed switch.

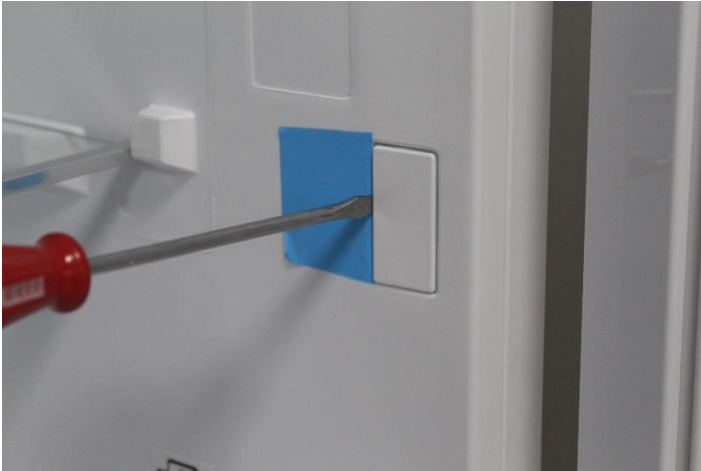

NOTE: Reed Switch is a very sensitive miniature electronic card. So during the assembly and disassembly be carefull not to damage it.

During the disassembly of the reed switch, there is a step on the edge of the plastic part which provides easier dissassembly and by that tool it can be taken out from the same place every time.

It must be assembled as this step should be in the invisible(inside of the refrigerator)part. Otherwise The distance which the lamp turn on/off may change.

After the assembly or replacement the service should check if the reed switch is damaged by giving energy and opening and closing the door.

 **CAUTION: The plug must be pulled out before the display is removed.**

1. Display can be removed with the disassembly tool. Do not use any sharp objects to remove the display.
2. Disassembly tool code is **42152193** (Pic-1)



Picture-1

3. Place and fix the disassembly tool on to display and pull to take out the display. (Pic-2)



Picture-2

4. Take out the display cable socket. (Pic-3)



Picture-3

Barcode and Serial Number Explanation:

Vestel refrigerator serial numbers are consist of 22 digits.

