

## Display and Control Panel

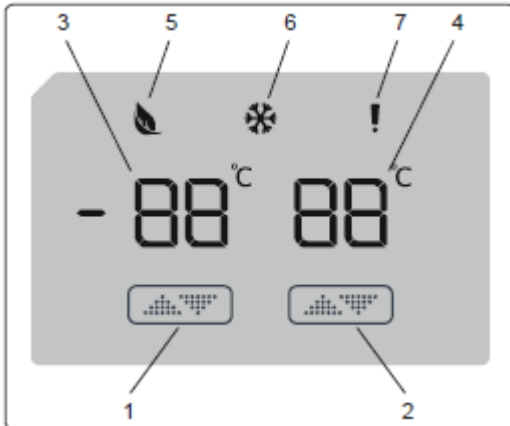

### Using the Control Panel

1. Enables the setting of the freezer to be modified and super freeze mode to be activated if desired.
2. Enables the setting of the cooler to be modified and super cool mode to be activated if desired.
3. Freezer set value screen.
4. Cooler set value screen.
5. Economy mode symbol.
6. Super freeze symbol.
7. Alarm symbol.

## 1.2 Operating your Fridge Freezer

Once you have plugged in the product, all symbols will be displayed for 2 seconds and the initial values will be shown as -18 °C on the freezer adjustment indicator, and +4 °C on the fridge adjustment indicator.

### 1.2.1 Freezer Temperature Settings

- The initial temperature value for the freezer setting indicator is -18 °C.
- Press the freezer set button once.

When you first press the button, the previous value will blink on the screen.

- Whenever you press the same button, a lower temperature will be set (-16 °C, -18 °C, -20 °C, -22 °C or -24 °C).
- If you continue to press the button, it will restart from -16 °C.

**NOTE:** Eco mode gets activated automatically when the temperature of the freezer compartment is set to -18°C.



### 1.2.2 Cooler Temperature Settings

- The initial temperature value for the cooler setting indicator is +4 °C.
- Press the cooler button once.
- Whenever you press the button, a lower temperature will be set (+8 °C, +6 °C, +5 °C, +4 °C, or +2 °C).
- If you continue to press the button, it will restart from +8 °C.

### 1.2.3 Super Freeze Mode

#### Purpose

- To freeze a large quantity of food that cannot fit on the fast freeze shelf.
- To freeze prepared foods.
- To freeze fresh food quickly to retain freshness.

#### How to use

To enable the super freeze mode, press and hold the freezer temperature setting button for 3 seconds. Once the super freeze mode has been set, the super freeze symbol on the indicator will be lit and the machine will beep to confirm the mode has been switched on.





## 492 INNER DISPLAY (DOUBLE CONTROL)



### Display and Control Panel

#### During Super Freeze Mode:

- The temperature of the Cooler may be adjusted. In this case, Super Freeze mode will continue.
- Economy mode cannot be selected.
- Super Freeze mode can be cancelled in the same way it is selected.

#### Notes:

- The maximum amount of fresh food (in kilograms) that can be frozen within 24 hours is shown on the appliance label.
- For optimal appliance performance in maximum freezer capacity, activate super freeze mode 3 hours before you put fresh food into the freezer.

Super freeze mode will automatically cancel after 24 hours or when the freezer sensor temperature drops below -25 °C.

Freezer Compartment	Cooler Compartment	Remarks
-18 °C	4 °C	For regular use and best performance.
-20 °C, -22 °C or -24 °C	4 °C	Recommended when environmental temperature exceeds 30 °C.
Super Freeze mode	4 °C	Must be used when you wish to freeze food in a short period of time.
-18 °C, -20 °C, -22 °C or -24 °C	2 °C	These temperature settings must be used when the environmental temperature is high or if you think the refrigerator compartment is not cool enough because the door is being opened frequently.

#### Demo mode:

Firstly the power is on, secondly within 1 minute user have to set the cooler 2 and push cooler temperature button for 10 seconds. Then economy, super and economy symbol will blink during the service mode. All functions can be adjusted to show how they are adjusted to the customer.

**Air Flow Diagram**

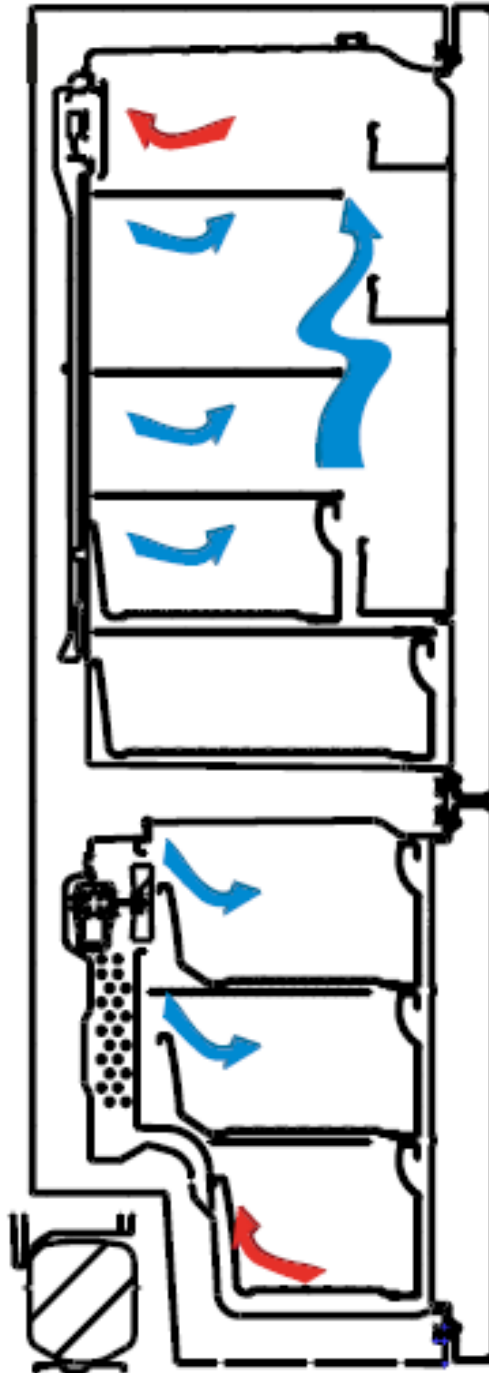

**Cutaway view: Air Flow Direction**

-  **Blown : Cold Air**
-  **Returned: Hot Air**

Air Flow Diagram

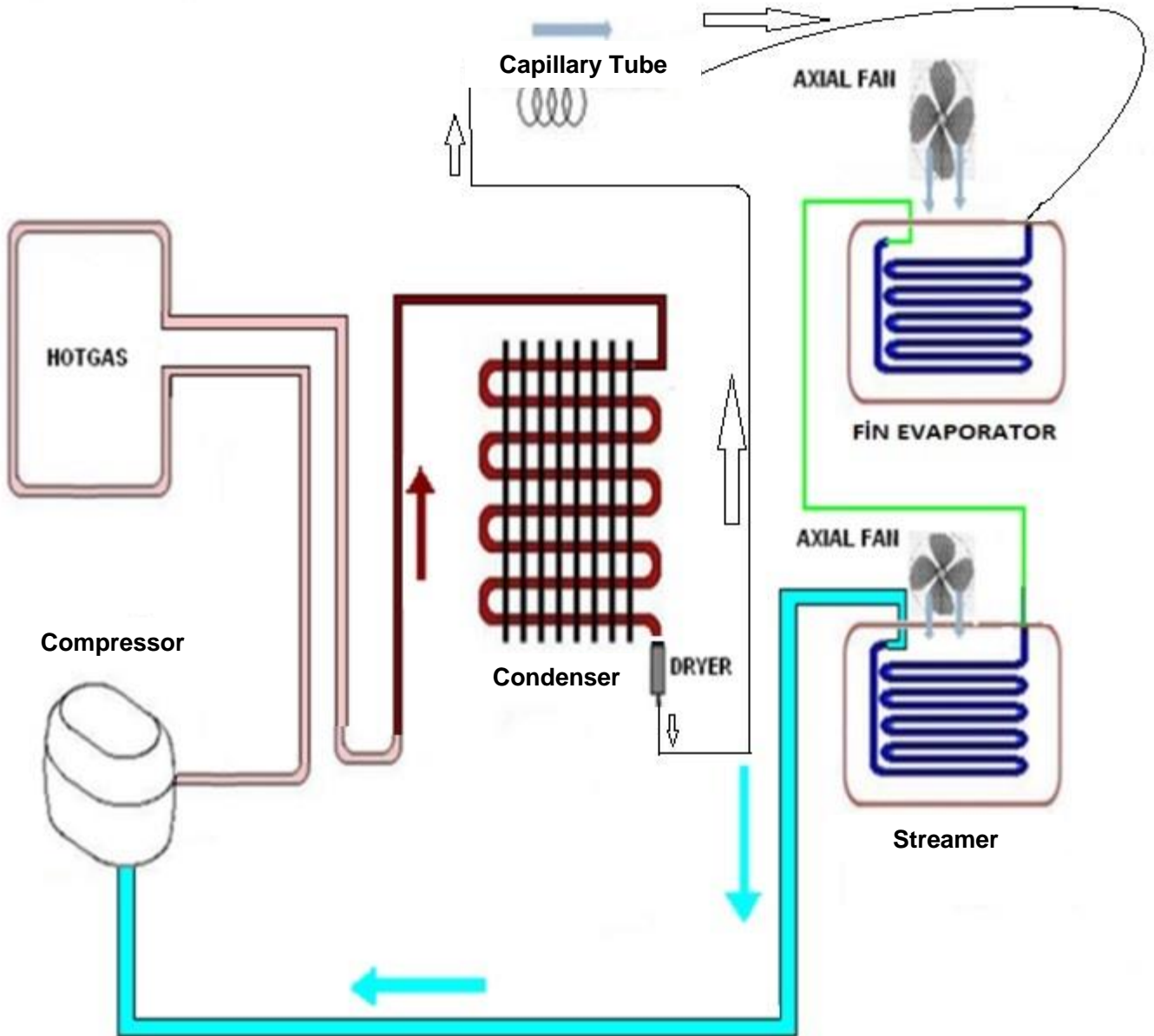

**This model is double controlled product without any valve. When both cooler & freezer set by user :**  
**Mainboard controls both the cooler sensor & freezer sensor. When cooler part reach requested value, if the freezer part haven't reach the requested level; compressor continues to run.**  
**While freezer continue to cool down, with the help of the RDH (Ref. Defrost Heater ), cooler will stay at constant value. When the freezer reach the requested value both compressor & RDH will be stop.**



## 492 INNER DISPLAY (DOUBLE CONTROL)



Used Component

### Resistance Values According To The Temperature Sensor (°C/Ohm Rates)

( For The Freezer Defrost and The Cooler Ambient Sensor)

45 °C/1kΩ	-1 °C/6.2kΩ
35 °C/1.5kΩ	-3 °C/6.8kΩ
30 °C/1.8kΩ	-5 °C/7.5kΩ
25 °C/2.2kΩ	-7 °C/8.2kΩ
19 °C/2.7kΩ	-12 °C/10kΩ
14 °C/3.3kΩ	-15 °C/12kΩ
10 °C/3.9kΩ	-20 °C/15kΩ
5.5 °C/4.7kΩ	-24 °C/18kΩ
1.5 °C/5.6kΩ	-31.5 °C/27kΩ
0 °C/6kΩ	-35.5 °C/33kΩ

### Sensor Resistance Values According To The Temperature (°C/Ohm Rates)

(For The Cooler Defrost Sensor)

45 °C/2.15kΩ	-1 °C/17.1kΩ
35 °C/3.26kΩ	-3 °C/19kΩ
30 °C/4.02k5Ω	-5 °C/21.1kΩ
25 °C/5kΩ	-7 °C/23.5kΩ
19 °C/6.53kΩ	-12 °C/30.8kΩ
14 °C/8.23kΩ	-15 °C/36.5kΩ
10 °C/9.95kΩ	-20 °C/48.6kΩ
5.5 °C/12.3kΩ	-24 °C/61.5kΩ
1.5 °C/15kΩ	-31.5 °C/98kΩ
0 °C/16.3kΩ	-35.5 °C/12.6kΩ



## 492 INNER DISPLAY (DOUBLE CONTROL)



### Service Mode

#### Entering service mode :

After the cooler temperature is set to 8, push cooler temperature button for 10 seconds.

- If there is a faulty situation, error code will be observed on screen. Otherwise nothing will be on the screen.
- Buzzer will sound beep for 0.1 sec. each 5 sec. during service mode.
- Alarm icon will blink

#### In the Service mode;

- Starting up by pressing the cooler set button until 1 led lights up. (economy symbol will light)

The below components are checked;

Compressor  
Defrost heater  
Balance heater  
Cooler Fan  
Freezer Fan  
Condanser Fan

- Manual defrost is done by pressing the cooler set button 2 times. (super symbol will light)  
6 Led lights continuously and manual defrost started. When the defrost sensor 10 C, manual defrost ends.

Mode can be canceled manually or automatically

Manual canceling; will be done by pushing REF button.

If manual canceling of this function is not performed in 30 min. service mode will be canceled.

Appliance will check if defrost is finished in this 30min. If YES, appliance will go on from previous set values. But if defrost is not finished, appliance will go on defrost till it finishes and then go on from previous set values.

- When the cooler set button is pressed 3 times, the instantaneous values of the sensor values can be read. (super and economy symbols will burn together) Negative temperature values will be indicated by blink.

THE VALUE OF THE NUMBER 1 SENSOR IS DISPLAYED IN THE FIRST TIME OF FUNCTION.

THE PREVIEW OF THE NEXT SENSOR IS SHOWED WHEN PRINTED IN ANY FREEZER BUTTON.

COOLER SENSOR INSTALLATION TEMPERATURE IS SHOWN IN FREEZER SET VALUE, "1" WRITER IN COOLER VALUE INDICATOR.

FREEZER SENSOR INSTALLATION TEMPERATURE IS SHOWN IN FREEZER SET VALUE, "2" WRITER IN COOLER VALUE INDICATOR

DEFROST SENSOR INSTALLATION TEMPERATURE IS SHOWN IN FREEZER SET VALUE, "3" WRITER IN THE COOLER VALUE INDICATOR

ATTENTION OF THE SENSOR AT THE SIZE OF FREEZER SET VALUE IS SHOWN, THE COOLER VALUE INDICATOR "4" WRITER

SERPANTINE SENSOR HEAT TEMPERATURE IS SHOWN IN FREEZER SET VALUE SEGMENT, "5" WRITER IN COOLER VALUE INDICATOR

WHEN PRIMING THE 5TH BEFORE PRINTING FREEZER BUTTON

MODE OF THE MODE OF THE COOLER BUTTON.

**Service Mode**

**To cancel Service Mode :** You can use same method as entering the Service Mode. After the cooler temperature is set to 8, push cooler temperature button for 10 seconds.

SENSOR	FREEZER SET VALUE	COOLER SET VALUE
(1) Freezer (Short-Open)	E	01
(2) Refrigerator (Short-Open)	E	02
(3) Defrost (Short-Open)	E	03
(4) AT sensor	E	04
(5) RDH Sensor	E	05

**Component defect on display**

DEFECT TYPE	FREEZER SET VALUE	COOLER SET VALUE
Compressor Defect	E	06
Defrost Heater Defect	E	07

**Low voltage error on display**

DEFECT TYPE	FREEZER SET VALUE	COOLER SET VALUE
Low voltage	E	08

**Cooling error on display**

DEFECT TYPE	FREEZER SET VALUE	COOLER SET VALUE
LF	E	09
LC	E	10
HC	E	11

### **NTC Sensor**

There are three types of sensors. They are cooler, freezer defrost, cooler defrost sensors. Cooler and freezer defrost sensors have the same features but their cable length is different. The resistance values of all sensors decrease when the temperature values of the sensors increase. For example, the resistance value that is 33 kΩ in the -35.5 °C goes down to 1kΩ in the 45 °C and therefore the ambient temperature should be considered while the sensor is being checked. If the ambient temperature is 25 °C, the measuring device shows about 2.2kΩ (if ntc sensor is steady).

### **When the refrigerator works on first time;**

If the cooler compartment defrost sensor and the freezer compartment defrost sensor are hotter than -5°C, the test system works automatically. These below components are tested automatically every 5 seconds.

- ❖The compressor and freezer fan motor starts and stops after 5 seconds.
- ❖The defrost resistance starts and stops after 5 seconds.
- ❖The cooler defrost resistance starts and stops after 5 seconds.
- ❖The DC Radial Fan starts and stops after 5 seconds.

After these steps, the system waits 5 minutes and then it will switch normal mod.

### **Freezer Defrost Program**

- According to the conditions of usage, the defrost might be activated after the min compressor running time; 8 hours or max total time; 55 hours. Below matters are also effected;
- Consisted ice amount,
- Door open-close,
- Sudden usage variance,
- Cooler sudden temperature rise,

### **Cooler Defrost Program**

The cooler defrost and the freezer defrost are operated parallel except those below. If the cooler defrost sensor does not feel 5°C three times during a particular period of time.

- Defrost will be activated after the refrigerator works max 9 hours. According to the conditions of usage, the defrost might be activated (due to mentioned those below) after the compressor works min 5 hours.
- Consisted ice amount,
- Door open-close,
- Sudden usage variance,
- Cooler sudden temperature rise,

### **Freezer Defrosting Time**

The Defrost is disabled when the defrost sensor temperature feels 8°C. If defrost time passes 37 minutes, defrost completing temperature will be rise to 15°C.

### **Cooler Defrosting Time**

The cooler defrost and the freezer defrost are operated parallel except those below. The cooler defrost will not work if the freezer defrost stops.

The defrost process stops when the defrost sensor temperature feels 7°C. At the low ambient temperature or when the compressor stops; to balance, defrost stops when the defrost sensor temperature feels 15°C. But if the defrost time or the compressor stopping time goes over 6 hours, the resistance will be stopped.

Compressor delay: First, the defrost process ends, the system waits 5 minutes, just after that the compressor is active.

### **In Case of Power Cut**

- All regulated parameters and functions are kept in memory when the power cut.
- When the electricity comes, if the defrost sensor temperature is lower than -5 °C the compressor works 5 minutes later. If it is higher than -5 °C.

### **Other Features**

Warnings : The door open warning is active 2 minutes later and it alarms.

Door Direction : It is possible to reverse the door.

Gasket : It is possible to change the gasket.

**Probable Faults**

<b>Unsufficient cooling</b>	Is the appliance too close to wall or heat sources (stove, central heating, oven, cooker etc.)?	It should be placed min 50cm distance from heat sources and min 5 cm from electrical ovens.
	Is the ambient temperature high?	Raise the thermostat value.
	Check whether putting the hot foods in the refrigerator?	Put the foods after get cold.
	Is there any gas leakage in refrigerant system?	Check all welding points in the system.
<b>The foods in the cooler compartment are freezing.</b>	Were the foods placed close to cooling air outlet?	Please do not block air outlets
	Is the cooler thermostat value high ? Is there any hot foods close to the cooler sensor?	Decrease the cooler thermostat value and do not put hot things close to the sensor.
<b>Are there any sweating or icing?</b>	Were the liquid foods in the closed containers?	Put the liquid foods into the closed containers.
	Were the hot foods put into the refrigerator?	Put it into after getting cold.
	Was the refrigerator door opened?	Do not leave the refrigerator door open and do not often open or close.
<b>Abnormal Noise</b>	Is the appliance on the flat surface?	The floor should be straight and balance the refrigerator with the help of the adjustable feet.
	Is the compressor feet loose	Fix it.
	Is the condenser or fan stationary normal?	Fix it.
	Do the capillary tube or all other tubes touch any where?	Fix it.

**1. Hold the top hinge cover and remove it toward that direction (Pic-1)**

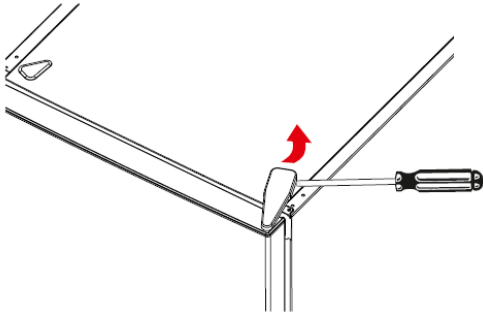

**Picture-1**

**2. Disconnect the display connector. Unscrew the screws fixing the top hinge and remove it. (Pic-2)**

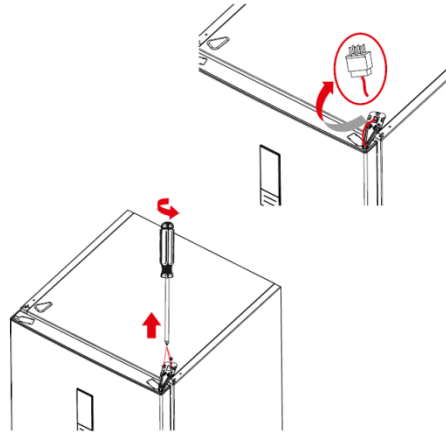

**Picture-2**

**3. Displace the top door (Pic-3)**

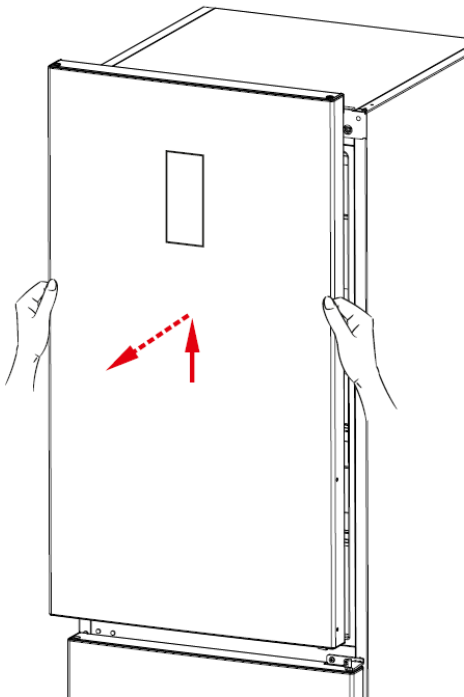

**Picture-3**

**4. Unscrew the two screws fixing the middle hinge and remove it.(Pic-4)**

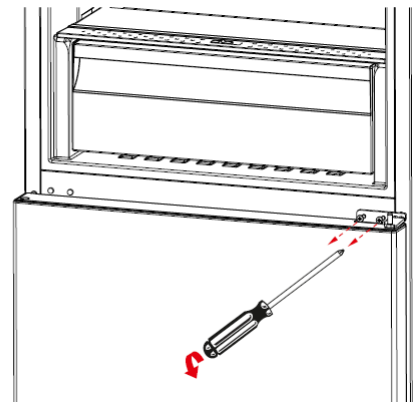

**Picture-4**

5. Displace the bottom door. (Pic-5)

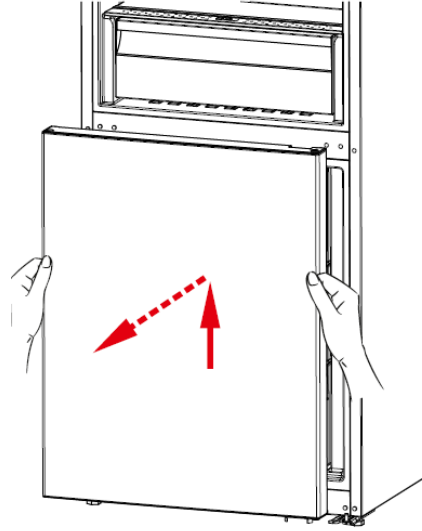

Picture-5

6. Unscrew the adjustable foot and unscrew the bottom hinge screws (Pic-6)

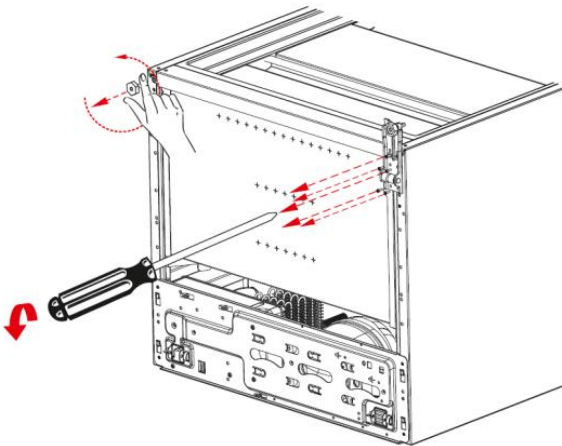

Picture-6

7. Unscrew the bottom hinge pin and screw it to other hole. (Pic-7)

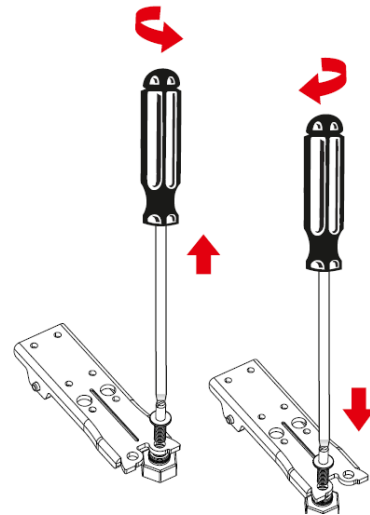

Picture-7

**8. Screw the bottom hinge to the left bottom side of refrigerator.  
Screw the adjustable foot there. (Pic-8)**

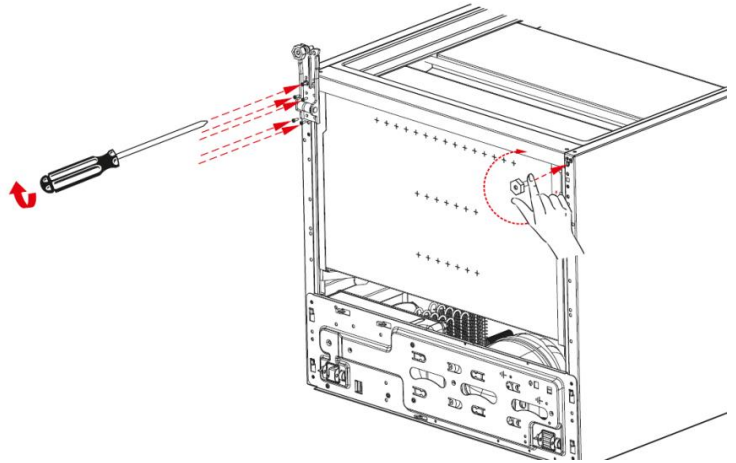

**Picture-8**

**9. Replace the top bushing and the top bushing cap at the bottom door. (Pic-9)**

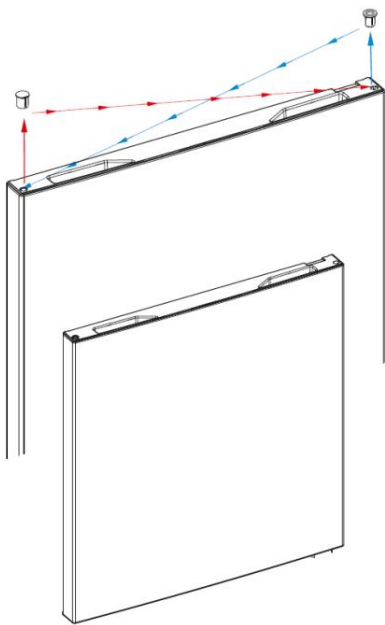

**Picture-9**

**10. Unscrew the two screws fixing stopper and stopper support plate under the bottom door. After that screw the other side. (Pic-10)**

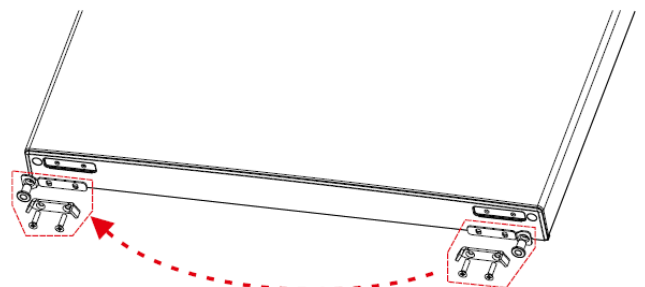

**Picture-10**

**11. Remove the support plastic under the upper door. Then re screw these parts to the other side symmetrically. (Pic-11)**

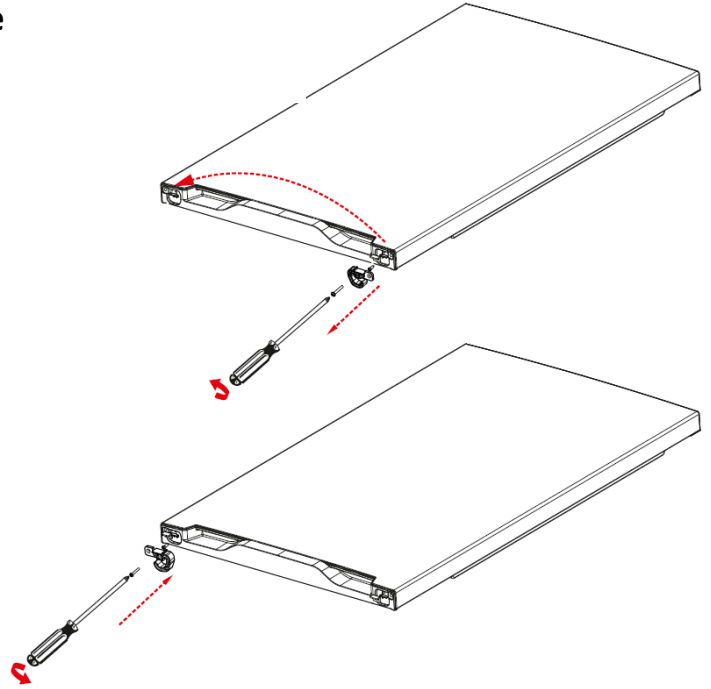

**Picture-11**

**12. Remove the socket cover-right of the top door. Remove the display socket. Please use the socket cover to hidden other housing (Pic-12)**

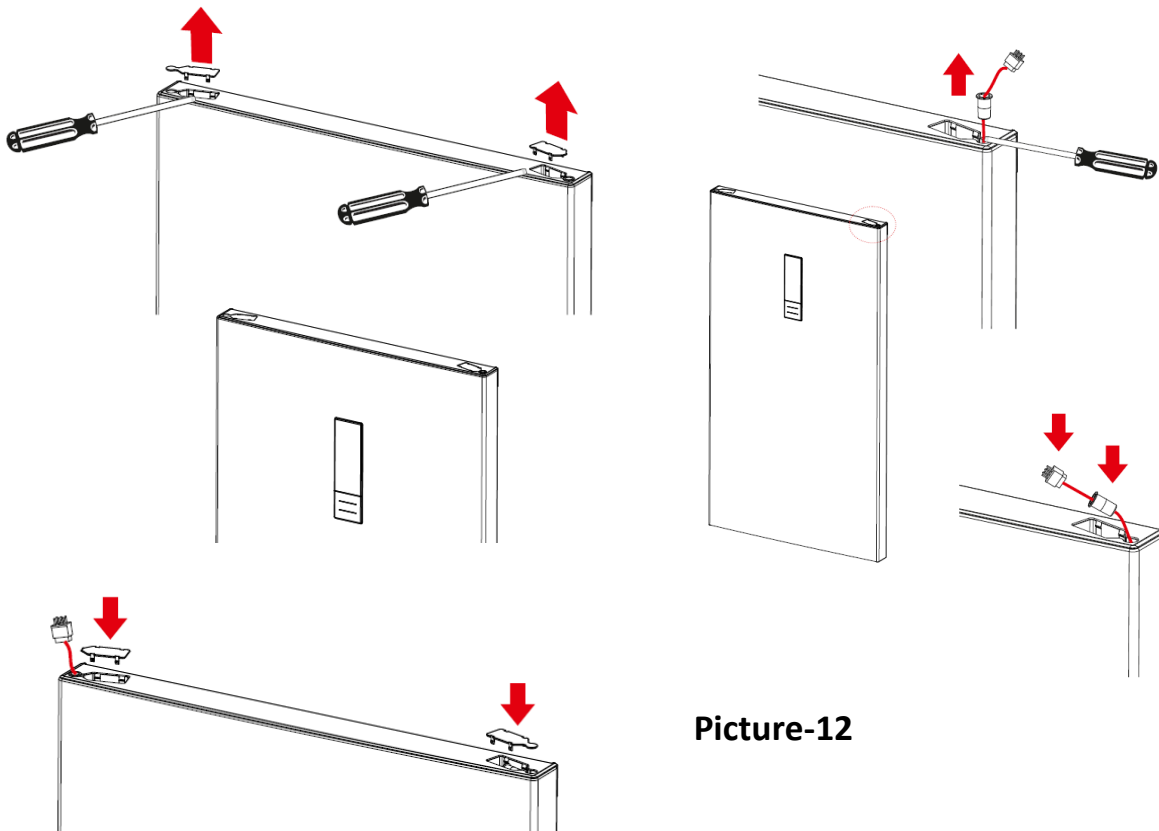

**Picture-12**

**13. Remove the middle hinge cover and then screw the screw on the side panel and assemble to the right side panel (Pic-13)**

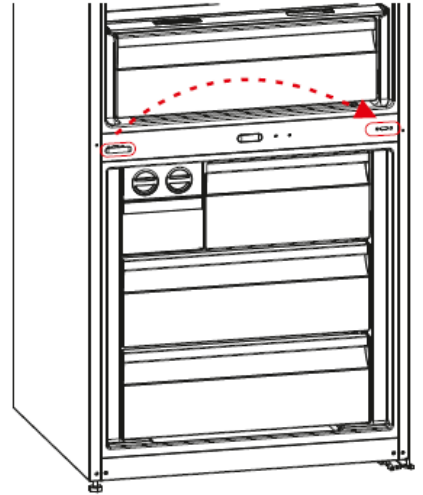

**Picture-13**

**14. Place the bottom door and rotate the middle hinge by 180°. After that, screw to the right side on the middle sheet. (Pic-14)**

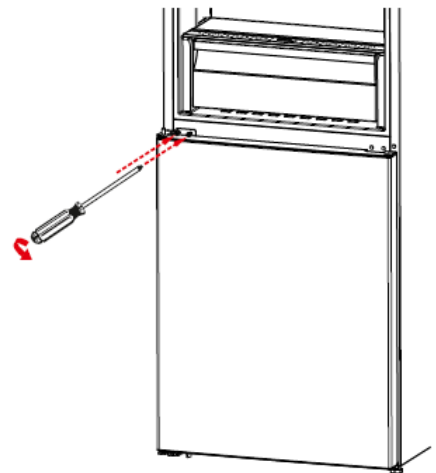

**Picture-14**

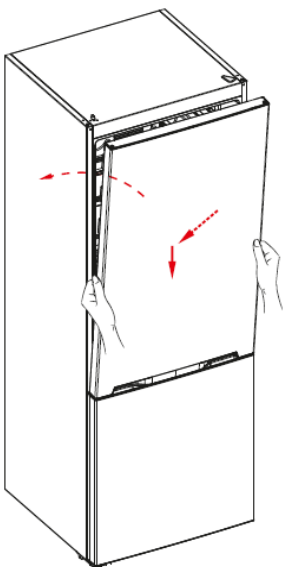

**Picture-15**

**15. Place the top door to the middle hinge and then connect the display connector and screw the top hinge to the top panel. Place the top hinge cover. (Pic-15)**

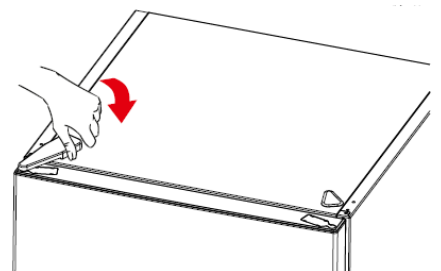
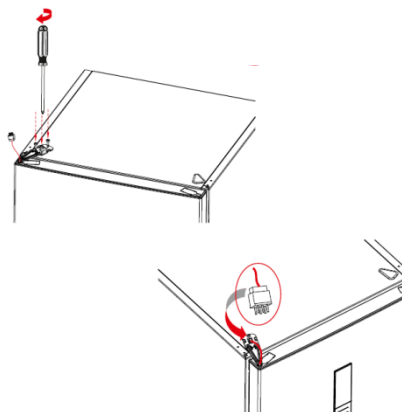

***CAUTION: The plug must be pulled out before the mainboard group is removed.***

**1. Unscrew the screws which are fixing the main board cover. (Pic-1 / Pic-2)**



**Picture-1**



**Picture-2**

**2. Pull the mainboard slightly forward and disconnect all the connectors and then replace it. Finally, place the mainboard cover and screw it. (Pic-3 / Pic-4)**

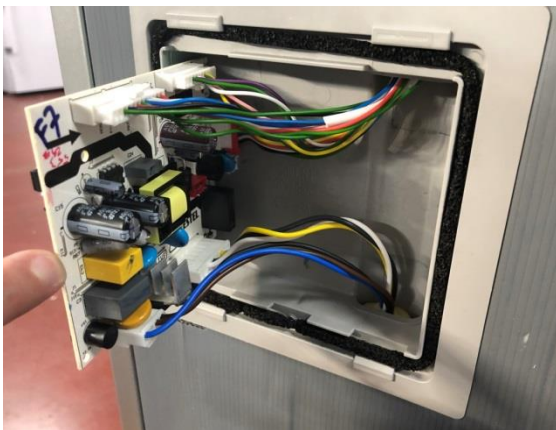

**Picture-3**



**Picture-4**

**1- First remove the glass shelves and chiller shelf (Pic-1)**



**Picture-1**

**2- Remove refrigerator multi-flow caps and unscrew the screws. (Pic-4)**



**Picture-2**

**3- Flex the multi flow by holding the fan cover and remove it. Disconnect the connector after removing the multi flow. (Pic-3)**



**Picture-3**

**1. Remove the fan cover by flexing the fan cover detail and then remove the fan motor by flexing the fan motor rubbers. (Pic-1/ Pic-2/Pic-3)**



**Picture-1**



**Picture-2**



**Picture-3**

**2. Place the rubbers to the fan motor. After that, first place the bottom two details of the fan motor and place the top two details by pressing-flexing it. (Pic-4/ Pic-5/Pic-6)**

*Note : The fan motor cable outlet should be at the top-left corner of it.*

**3. After the connector is connected, place it by flexing it and then reassemble the multi flow by screwing.**



**Picture-4**



**Picture-5**



**Picture-6**

**1. Stick a tape to protect plastic. Insert a flat screwdriver into the gap and remove the cover.  
(Pic-1)**



**Picture-1**

**2. Remove the led strip light from its housing. (Pic-2)**



**Picture-2**

**3. Disconnect the connector and change the led light strip. (Pic-3)**

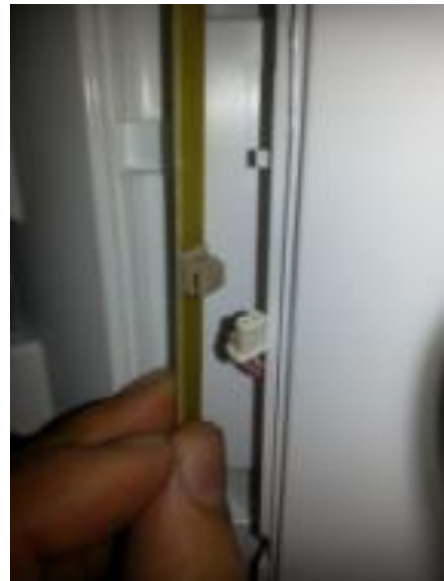

**Picture-3**

**4. First, place the bottom point of the led light strip and then place towards other side.(Pic-4)**



**Picture-4**

**5. Reassemble the led cover. (Pic-5)**



**Picture-5**

Remove the sensor cover by pulling forward and disconnect sensor connector.

**Refrigerator Sensor**



**Picture-1**



**Picture-2**



**Picture-3**

**Freezer Sensor**



**Picture-1**



**Picture-2**

***CAUTION: Pay attention not to damage to the sensor cover details!***

**1. Remove the freezer baskets, freezer glass shelves and icematic (Pic-1 / Pic-2)**



**Picture-1**



**Picture-2**

**2. Unscrew the screw fixing the multiflow group. (Pic-3)**

**3. Removing the freezer bottom cover by flexing back side of it. (Pic-4)**



**Picture-3**



**Picture-4**

## Replacement of Fin Evaporator Assy

1. Disconnect to evaporator connector. (blue connector) (Pic-1)

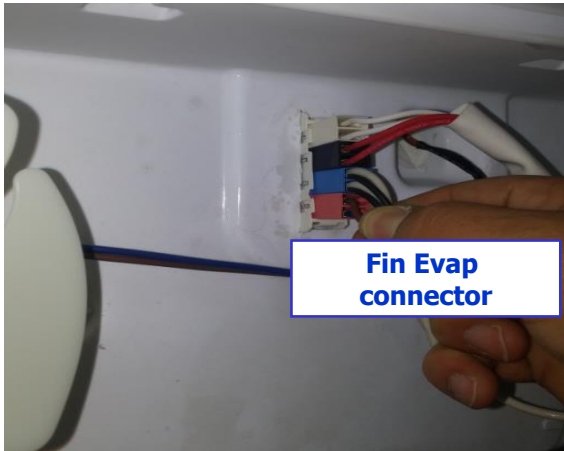

Picture-1

2. Remove the evaporator by pulling forward in a horizontal direction. (Pic-2)



Picture-2

**Do not push it up or down. You may broke the fixing plastics.**

### Removing The Thermal Fuse

1. Remove the thermal fuse connector. (Pic-1) (black-white connector)

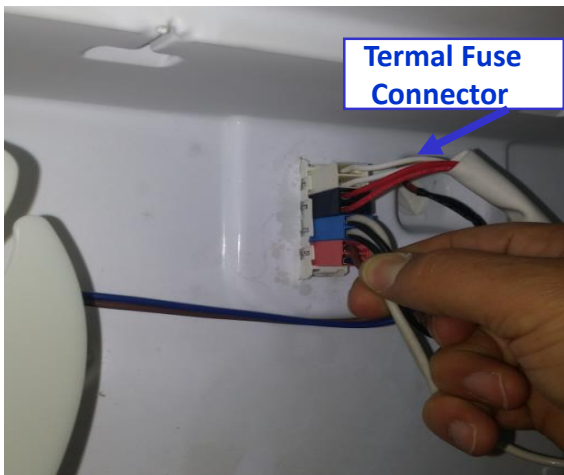

Picture-1

2. Thermal fuse has two details. These details hold on to the pipe. It could be removed easily.(Pic-2)



Picture-2

1. Unscrew the bottom tray screws and displace it from the compressor basement. (Pic-1)
2. Remove the fan motor connector. (Pic-2)
3. Unscrew the screws fixing the evaporating tray. (Pic-3)
4. Remove the evaporating tray to displace the fan motor. (Pic-4)



Picture-1



Picture-2



Picture-3



Picture-4

5. Unscrew the fan motor screws. (Pic-5)

6. Remove the propeller. (Pic-6 / Pic-7)



Picture-5



Picture-6



Picture-7

### Removing/Assembling The Reed Switch

Take the reed switch out of its place with a screwdriver. Then Disconnect the connectors of the Switch and remove it.

**NOTE:** Reed Switch is a very sensitive miniature electronic card. So during the assembly and disassembly be carefull not to damage it.



***CAUTION: The plug must be pulled out before the display is removed.***

**1.** The display can be removed with the help of a horizontal brace or a spatula. Avoid screwdriver etc. in display disassembly which will apply pressure to the liner plastic on single point. This will damage the liner. By placing the spatula near the door side of the refrigerator between the display and the housing in the body. Remove it from its slot. (Picture-1) (Picture-2)



**Picture-1**



**Picture-2**

**2.** The display tabs are fixed (B) at the bottom and flexible (A) near the door side of the refrigerator. (Picture-3)



**Picture-3**

**B**

**A**

**3.** Unplug the cable connector on the display board and remove the display assembly. (Picture-4)



**Picture-4**