



1. Freezer temperature setting.
2. Super Freeze mode indicator
3. Fridge temperature setting
4. Super Cooling mode indicator
5. Holiday mode indicator
6. Eco mode indicator
7. Alarm indicator
8. Child Lock mode indicator
9. Screen selector
10. Decrease value
11. Increase value
12. Mode Selector
13. Child Lock Selector

Super freeze mode

Purpose

- To freeze a large quantity of food that cannot fit on the fast freeze shelf.
- To freeze prepared foods.
- To freeze fresh food quickly to retain freshness.

How to use

- Press  icon (#9 on control panel diagram), until the 'Freezer temperature setting' is selected (#1).
- Once Freezer temperature setting is selected, the temperature will flash.
- Press the  icon (#10) repeatedly until the 'Super Freeze logo appears'  in the top left corner (#2)
- Once the Super Freeze mode has been set, the machine will beep to confirm the mode has been switched on.
- After the beep the original temperature of the freezer will appear on screen.
- Mode can be cancelled by repeating the above instructions from the beginning.

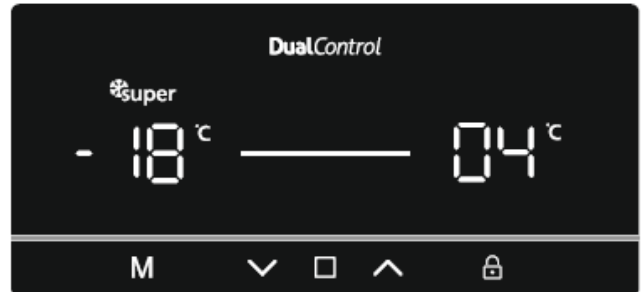

During this mode:



- Temperature of the fridge compartment may be adjusted, this will not impact Super Freeze Mode.
- Economy and holiday mode cannot be selected whilst Super Freeze is active.

Super cool mode

Purpose

- To cool and store a large quantity of food in the fridge compartment.
- To quickly cool drinks.

How to use

- Press  icon (#9 on control panel diagram), until the 'Fridge temperature setting' is selected (#1).
- Once fridge temperature setting is selected, the temperature will flash.
- Press the  icon (#10) repeatedly until the 'Super Cool logo appears'  in the top right corner (#4)
- Once the Super Cool mode has been set, the machine will beep to confirm the mode has been switched on.
- After the beep the last temperature of the fridge will appear on screen.
- Mode can be cancelled by repeating the above instructions from the beginning.



During this mode:

- Temperature of the freezer compartment may be adjusted, this will not impact Super Cool Mode.
- Economy and holiday mode cannot be selected whilst Super Cool is active.

Economy Mode

Purpose

Energy savings. During periods of less frequent use (door opening) or absence from home, such as a holiday, Eco program can provide optimum temperature whilst saving power.

How to Use

• Press **M** icon (#12 on control panel diagram), until the 'Eco Mode' icon  appears (#6).

- Once the 'Eco mode' has been set, the machine will beep to confirm the mode has been switched on.
- After the beep the both the fridge and freezer temperature setting (#1 and #3) will display an 'E'.
- Eco Mode can be cancelled by pressing the **M** Icon (#12).

During this mode:

- The freezer and fridge temperature may be adjusted however the adjustment will not be made until Eco Mode is cancelled. When economy mode is cancelled, the selected setting values will be activated and the temperature(s) will be adjusted.
- Super Cool or Super Freeze mode can be selected, however by selecting either modes Eco Mode is cancelled immediately.
- Holiday mode can only be selected after cancelling the economy mode.

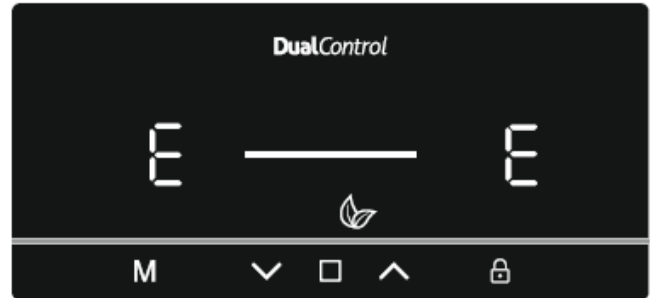

Holiday Mode

Purpose

Holiday mode is to be used if the device is to be left for an extended period. During Holiday mode only the freezer compartment remains active.

How to Use

• Press **M** icon (#12 on control panel diagram), until the 'Holiday Mode' icon  appears (#5).

- Once the 'Holiday mode' has been set, the machine will beep to confirm the mode has been switched on.
- After the beep the fridge will display '--' and the freezer will display the -18 °C set temperature.
- Holiday Mode can be cancelled by pressing the **M** icon (#12).

During this mode:

- Freezer and fridge temperature may be adjusted however the adjustment will not be made until Holiday Mode is cancelled. When Holiday mode is cancelled, the selected setting values will be activated and the temperature(s) will be adjusted.
- Super Cool or Super Freeze mode can be selected, however by selecting either modes Holiday Mode is cancelled immediately.
- Eco Mode can only be selected after Holiday mode has been cancelled.

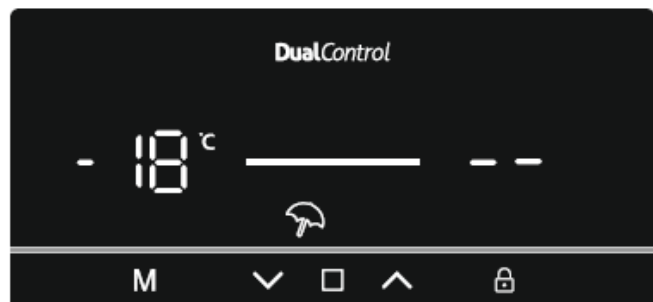

Drink Cool Mode

Purpose

This mode is used to cool drinks within an adjustable time frame.

How to Use

- Press **M** icon (#12) and **□** (#9) icons simultaneously for five seconds.
- The cooler temperature set indicator will start showing '05'. This value will flash on screen
- Users can either press **∨** or **∧** buttons to adjust the time period (05, 10, 15, 20, 25 or 30 minutes)
- When you select the time the numbers will blink 3 times on screen and sound beep beep. If the user do not press any button within 2 seconds the time will be set.
- The machine will then set the time, the remaining time will be shown on screen
- Once the total time has elapsed, an alarm will sound
- Cool Drink Mode can be cancelled by following pressing the **M** icon (#12) and **□** (#9) icons simultaneously for five seconds.

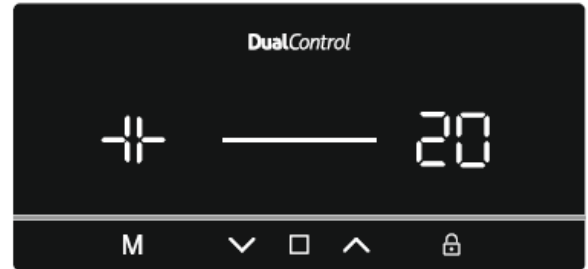

During this mode:

- When drink cool and child lock modes are active, the child lock mode must be cancelled in order to stop the alarm sound
- While using this mode, you must regularly check the temperature of the bottles. When the bottles are cool enough, you must take them out of the appliance.
- Bottles can explode if left in the appliance for too long with drink cool mode active.

Screen Saver Mode

Purpose

This mode saves energy by switching off all control panel lighting when the panel is left inactive.

How to Use

- Screen saver mode will be activated automatically after 30 seconds.
- If you press any key while the lighting of the control panel is off, the current machine settings will reappear on the display to let you make any change you wish.
- If you do not cancel the screen saving mode or press any key for 30 seconds, control panel will remain off.

To deactivate the screen saving mode,

- To cancel the screen saving mode, first of all, you need to press any key to activate the keys and then press and hold the Mode button "**M**" (#12) for 3 seconds.
- To reactivate screen saving mode, press and hold the mode button "**M**" (#12) for 3 seconds.

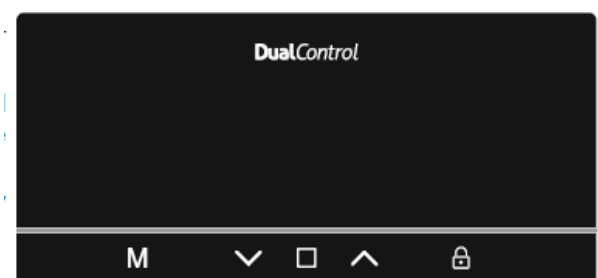

Child Lock

Purpose

Child lock can be activated to prevent any accidental or unintentional changes being made to the appliance settings.

Activating Child Lock

Press and hold child lock button  (#13) for 5 seconds.

Cancelling Child Lock

Press and child lock button  (#13) for 5 seconds.

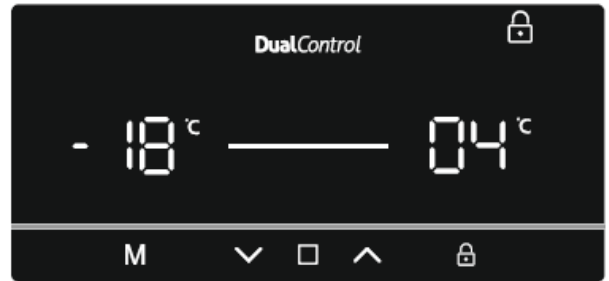

Door Open Alarm Function

If the fridge door is left open for more than 2 minutes, the appliance will beep

Demo Mode

This mode will be use for only sales points by salesman to show functions & modes to customer without operating components as a compressor, fan, motor..Etc.

Entering Demo mode:

- Firstly the power is on , secondly within 1 minute user will push mode & child lock button at the same time , Then appliance will go on «dE» and «On» every 10 seconds this operations will occur.
- All functions can be adjusted to show how they are adjusted to the customer.



Canceling Demo mode:

For cancelling; Same operation will be used. If user will push mode & child lock button at the same time, demo function will be cancelled.

When appliance is Demo mode; if plug is removed or there is an electricity breakdown; demo mode will continue with current settings after user plug into or electricity breakdown finish.



Control Panel

Freezer temperature settings

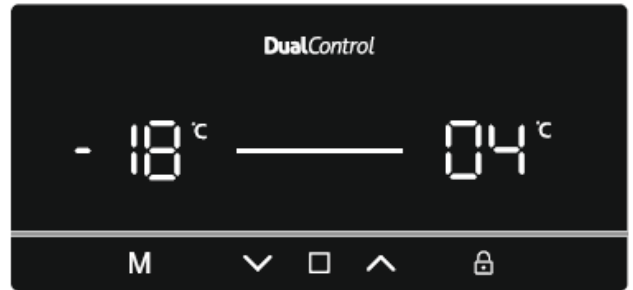
- Press  on (#9 on control panel diagram), until the 'Freezer temperature setting' is selected (#1).
- Once Freezer temperature setting is selected, the temperature will flash.
- Users can then use the up or down arrow ( / ) to set the temperature (-16, -18, -20, -22, -24°C and Super Freeze Mode).
- If Super Freeze mode or Eco mode is activated, the temperature will not change until the mode is cancelled.



Cooler temperature settings

- Press  icon (#9 on control panel diagram), until the 'Fridge temperature setting' is selected (#1).
- Once Fridge temperature setting is selected, the temperature will flash.
- Users can then use the up or down arrow ( / ) to set the temperature (8, 6, 5, 4, 2°C and Super Cool Mode).
- If Super Freeze mode or Eco mode is activated, the temperature will not change until the mode is cancelled.

Warnings About Temperature Adjustments

- Your temperature adjustments will not be deleted when an energy breakdown occurs.
- It is not recommended that you operate your fridge in environments colder than 10°C.
- Temperature adjustments should be made according to the frequency of door openings, the quantity of food kept inside the fridge and ambient temperature of the placement of your fridge.
- Your fridge should be operated up to 24 hours according to the ambient temperature without interruption after being plugged in, this is so it is completely cooled. Do not open the doors of your fridge and do not place food inside it during this period.
- A 5 minute delay function is applied to prevent damage to the compressor of your fridge, when you take the plug out and then plug it back in again after an energy breakdown has occurred. Your fridge will start to operate normally after 5 minutes.
- Your fridge is designed to operate in the ambient temperature intervals stated in the standards, according to the climate class stated in the information label. We do not recommend operating your fridge out of the stated temperatures value limits in terms of cooling effectiveness.
- This appliance is designed for use at an ambient temperature within the 10°C - 43°C range.

Air Flow Diagram

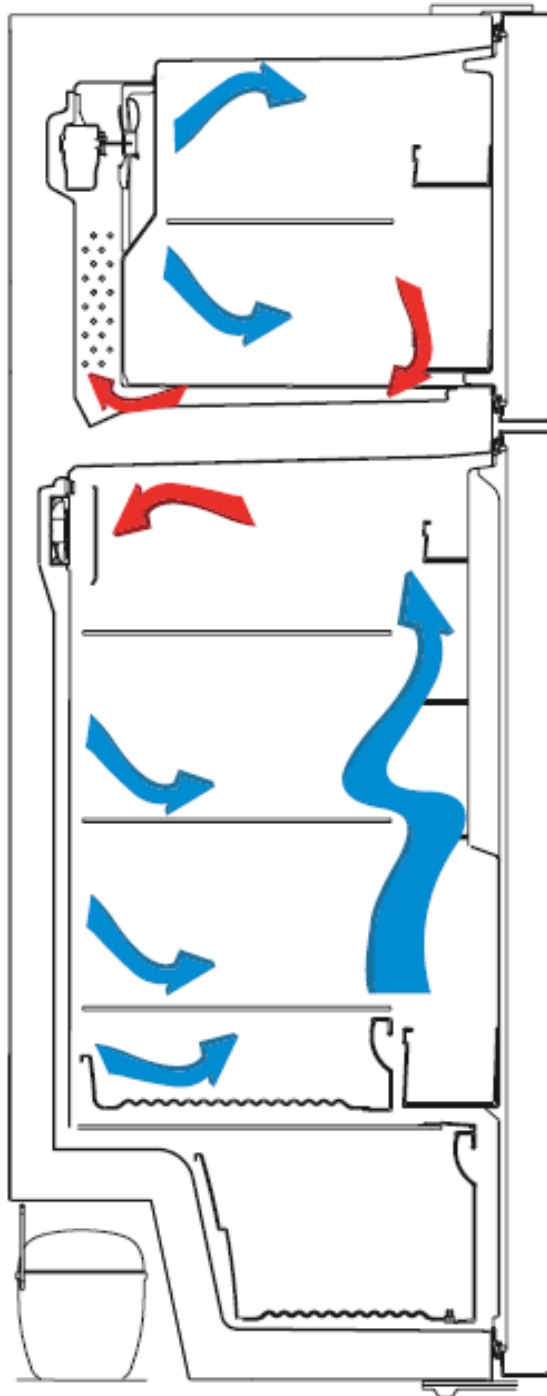

Cutaway view: Air Flow Direction



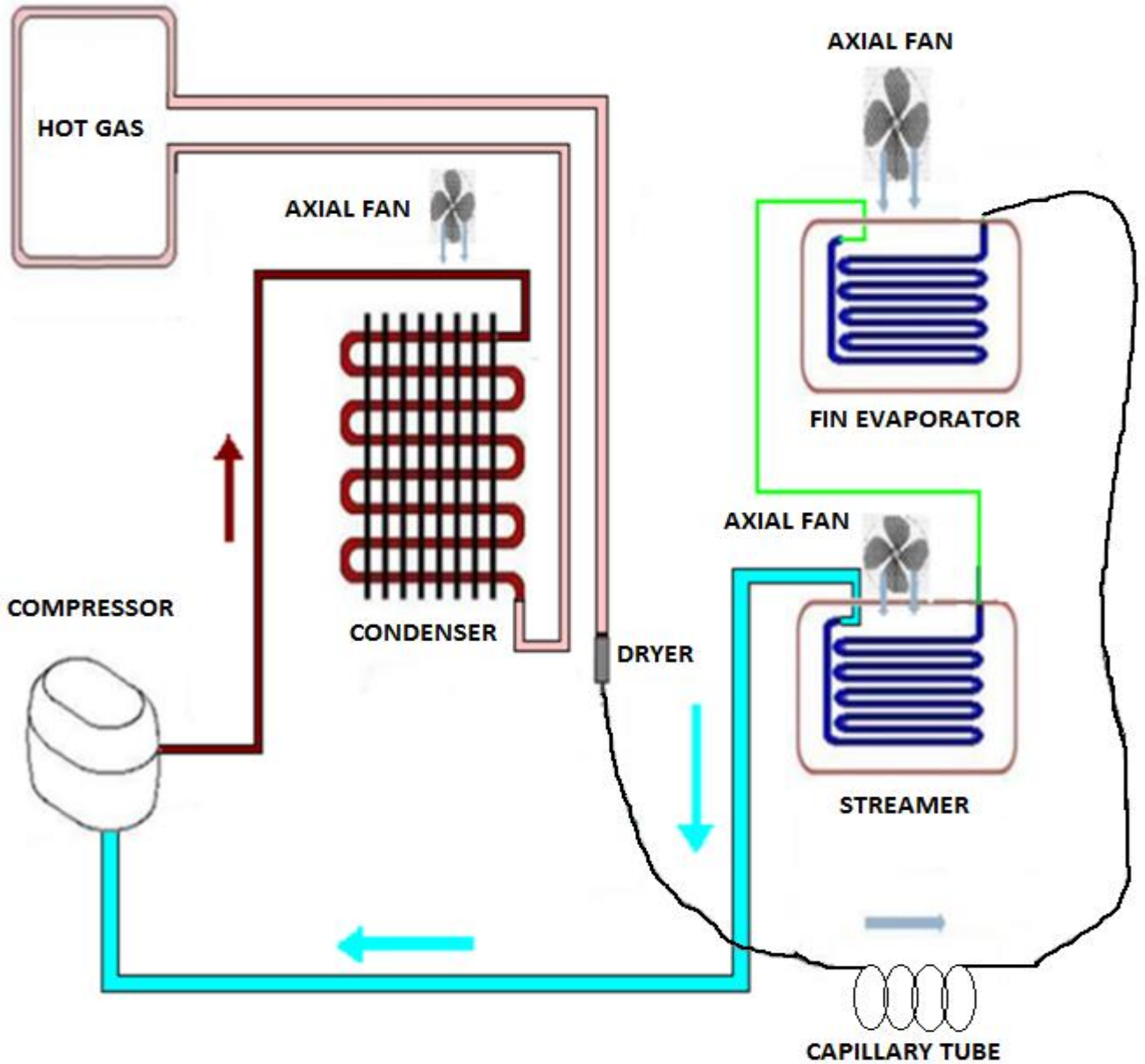

The freezer fan motor and the condenser fan motor work parallel time with the compressor. The freezer fan motor works when the freezer compartment door is opened. It is normal.

The cooler fan motor works parallel time with the compressor. However it could work while the compressor is stopped or the cooler is defrosting.



NO-FROST 643 ELECTRONIC



Special Programs

When you first start the appliance

If the freezer and defrost sensors are warmer than -5°C , then the automatic test starts. The below listed components will be tested respectively with 5 second intervals.

- Radyal fan for 5 seconds
- Drain heater for 5 seconds
- Defrost heaters for 5 seconds
- Evaporator fan motor for 5 seconds
- Compressor for 5 seconds

After 5 seconds, the appliance will start to run.

Defrost algorithm

Defrosting activates after 55 hours of total running time of refrigerator or 18 hours of total compressor running time. Up to below mentioned reasons running times might decrease to 12 hours for refrigerator or 15 hours for compressor.

- Amount of ice formed,
- Number of times the door is opened and closed,
- Duration the door remained opened,
- Sudden usage change ,
- Sudden Cooler Compartment temperature increase,
- Sudden Freeze Compartment temperature increase,

Freezer Defrosting time

Under normal conditions, defrosting period ends when the defrost sensor measures 8°C . But if the defrosting period exceeds 37 minutes, then the defrosting mode completion temperature will be rised to 15°C .

Cooler Defrosting time

The cooler defrost and the freezer defrost are operated parallel except those below.

If the cooler defrost sensor does not feel 5°C three times during a particular period of time.

• Defrost will be activated after the refrigerator works max 9 hours. According to the conditions of usage, the defrost might be activated (due to mentioned those below) after the compressor works min 5 hours.

- Consisted ice amount,
- Door open-close,
- Sudden usage variance,
- Cooler sudden temperature rise,

Delay of the compressor run

Compressor will be started after 5 minutes of defrost mode.

Low Voltage Program

In case of supply voltage lower than 170 V for more than 5 seconds, the low voltage program will stop the compressor, evaporator fan motor, condenser fan motor and also the super freezing super cooling functions. If this situation happens during the defrost mode, then the appliance will stop during defrosting.

When the supply voltage reaches a value greater than 180V, the appliance will start again from the defrost mode.

If the appliance was not stopped during the defrost mode, then will be stopped for minutes more for compressor secure start-up and will be started from the last setted program.

When the electricity is off

- All the parameters and functions will be kept in the memory (except the child lock function)
- When the electricity is on if the defrost sensor measures $<5^{\circ}\text{C}$ then the compressor will be started after 5 minutes.
- The appliance will be started with the last program setted.



NO-FROST 643 ELECTRONIC



SERVICE MODE

Push freezer temperature button continuously. During this time, open and close the cooler or freezer door for least 3 times. The appliance will enter service mode 3 sec. late.

- If there is a faulty situation, error code will be observed on screen. Otherwise nothing will be on the screen.
- Buzzer will sound beep for 0.1 sec. each 5 sec. during service mode.
- Child lock icon will blink
- Service function could be activated by pushing «Mode» button

SERVICE FUNCTIONO	
	While display is on service mode, it could be changed among service functions by touching mode icon
TOUCHING M (MODE) BUTTON ONE TIME.	STARTING MODE
	Eco icon blinks
	The number of components which is controlled is shown at freezer segments of display Eco icon goes off when the starting test finishes and then display returns to initial service mode.
TOUCHING M (MODE) BUTTON TWO TIMES.	MANUAL DEFROST
	Holiday icon blinks
	Defrost might be finished manually or automatically.
	Defrost might be finished manually by using the screen select button. Holiday icon goes off and display returns to initial service mode.
	Automatic defrost operates according to the standard defrost time. Holiday icon goes off when he when the manual defrost ends and display returns to initial service mode.
TOUCHING M (MODE) BUTTON THREE TIMES.	DAMPER MOTOR CONTROL MODE (this is a general function for other models which have damper)
	SC icons blink.
	There is no function due to not having damper component in the product Unless touch anything on the screen for 5 minutes, this function will be finished.
	SC icons goes off and display returns to initial service mode.
TOUCHING M (MODE) BUTTON FOUR TIMES.	CURRENT TEMPERATURE VALUES INDICATOR
	Sf icons blink.
	Current temp. Value of freezer set sensor is shown on cooler set segment. Freezer set segment shows "1"
	After touching child lock button one time, current temp. Value of cooler sensor is shown on cooler set segment. Freezer set segment shows «2"
	After touching freezer set icon one more time, current temp. Value of defrost sensor is shown on cooler set segment. Freezer set segment shows «3"
	After touching child lock button one more time, Constant value is shown on cooler set segment due to not being an ambient sensor in the appliance. Freezer set segment shows «4" (this is a general function for other models which have ambient sensor)
	After touching child lock button one more time, current temp. Value of cooler serpentine sensor is shown on cooler set segment. Freezer set segment shows «5"
	Unless touch child lock button for 5 minutes, function will be finished automatically.
	Touching screen select button , function will be finished manually.
	Sf icon goes off and display returns to initial service mode.
TOUCHING M (MODE) BUTTON FIVE TIMES.	DOOR SWITCH CONTROL
	No icons at display
	Cooler set segment gives information about cooler door
	Mode just could be deactivated by cooler set button.



NO-FROST 643 ELECTRONIC



User and Service Mode Error Message

**Error codes can appear in normal use and they will be on a screen for 10 seconds. SR (Symbol blinks. No alarm sounds).

SENSOR	TEMPERATURE	USER MODE REACTION	SERVICE MODE REACTION
(1) Freezer	> +50 °C or <-50 °C (sensor is short or open)	Display E 01	Display E 01
(2) Refrigerator		Display E 02	Display E 02
(3) Defrost		Display E 03	Display E 03
4) Serpantin		In normal mode, Serpantin sensor defect will not be shown.	Display E 05

Component defect on display

DEFECT TYPE	DETAILS	USER MODE REACTION	SERVICE MODE REACTION
Compressor Defect	Defrost sensor temp > -10°C (D sensor temp.unchanges for 10 min.continuous compressor run)	Display E 06	Display E 06
Defrost Heater Defect	Defrost sensor < 0°C	Display E 07	Display E 07



NO-FROST 643 ELECTRONIC



User and Service Mode Error Message

Low voltage error on display

DEFECT TYPE	DETAILS	USER MODE REACTION	SERVICE MODE REACTION
Low voltage	Power supply < 170	Display E 08	Display E 08

Cooling error on display

Note: To prevent the wrong alarms, this alarm status is disabled on following conditions:

- During the first 6 hours after the product was firstly connected.
- During the defrost period
- During the first two hours after a defrost
- During the first 2 hours that one of the doors was open.

DEFECT TYPE	DETAILS	USER MODE REACTION	SERVICE MODE REACTION
Freezer sensor > -10°C	Freezer compartment is not cool enough	Display E 09	Display E 09
Ref. sensor > +10°C and if Holiday mode is not active	Refrigerator compartment is warm	Display E 10	Display E 10
Ref. sensor < -5°C	Refrigerator compartment is so cool	Display E 11	Display E 11
F sensor > -10°C and R sensor >15°C and if Holiday mode is not active	Freezer and Refrigerator compartment both are not cool enough	Display E 09 ,E 10	Display E 09 ,E 10

Reversing the door

1. Hold the top hinge cover and remove it toward that direction (Pic-1)



Picture-1

2. Disconnect the display connector. Unscrew the screws fixing the top hinge and remove it. (Pic-2)



Picture-2

3. Displace the top door (Pic-3)



Picture-3

4. Unscrew the two screws fixing the middle hinge and remove it. (Pic-4)



Picture-4

5. Displace the bottom door. (Pic-5)



Picture-5

6. Unscrew the adjustable foot (Pic-6)



Picture-6

7. Unscrew the bottom hinge screws. (Pic-7)



Picture-7

8. Unscrew the bottom hinge pin and screw it to other hole. (Pic-8)



Picture-8

9. Unscrew the left bottom adjustable foot and the screws fixing roller. After that screw them to other side (Pic-9)



Picture-9

10. Screw the bottom hinge to the left bottom side of refrigerator. Screw the adjustable foot there. (Pic-10)



Picture-10

11. Unscrew the two screws fixing stopper and stopper support plate under the cooler door. After that screw the other side. (Pic-11)



Picture-11

12. Replace the top bushing and the top bushing cap at the bottom door. (Pic-12)



Picture-12

13. Remove the catcher under the top door and then stopper reinforcement plate and screw to the right side (Pic-13)



Picture-13

14. Remove the middle hinge cover and then screw the screw on the side panel (Pic-14.1) and assemble to the right side panel (Pic-14.2)



Picture-14.1



Picture-14.2

15. Place the bottom door (Pic-15.1) and rotate the middle hinge by 180°. After that, Screw to the right side on the middle sheet. (Pic-15.2)



Picture-15.1



Picture-15.2

16. Remove the socket cover-right of the top door (Pic-16.1)
 Remove the display socket (Pic-16.2)
 Please use the socket cover to hidden other housing (Pic-16.3 / Pic-16.4)



Picture-16.1



Picture-16.2



Picture-16.3



Picture-16.4

17. Place the top door to the middle hinge and then connect the display connector and screw the top hinge to the top panel. (Pic-17)

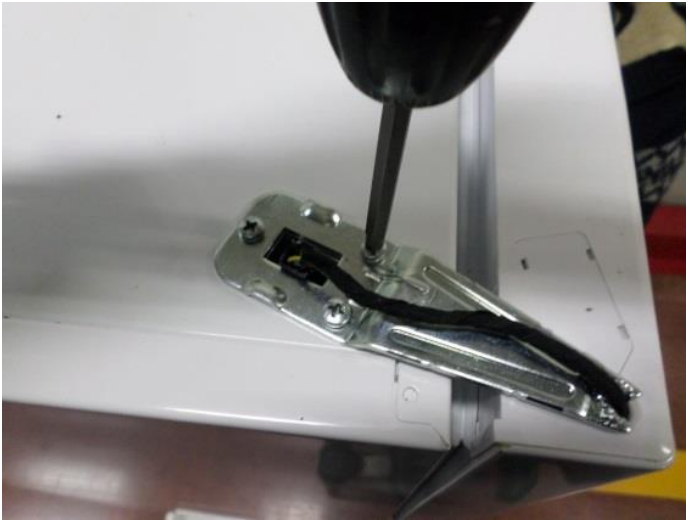

Picture-17

18. Place the top hinge cover. (Pic-18)



Picture-18

⚠ CAUTION: The plug must be pulled out before the display is removed.

1. Display can be removed with the disassembly tool. Do not use any sharp objects to remove the display.
2. Disassembly tool code is **42152193** (Pic-1)



Picture-1

3. Place and fix the disassembly tool on to display and pull to take out the display. (Pic-2)



Picture-2

4. Take out the display cable socket. (Pic-3)



Picture-3

CAUTION: The plug must be pulled out before the mainboard group is removed.

1. Unscrew the three screws which are fixing the mainboard cover by using the screwdriver. (Pic-1 / Pic-2 / Pic-3)
2. Remove the cover after the screws are removed.(Pic-4)



Picture-1



Picture-2

3. Pull the mainboard slightly forward and disconnect all the connectors and then replace it. Finally, place the mainboard cover and screw it.



Picture-3



Picture-4

Removing The Cooler Multi Flow

1. Remove the cooler glass shelves and the chiller. (Pic-1)



Picture-1

2. Stick one tape to each air duct to avoid scratching. Remove the screw caps by using a flat screwdriver and screw the screws. (Pic-2.1/Pic-2.2)



Picture-2.1



Picture-2.2

3. Flex the multi flow by holding the fan cover and remove it. Disconnect the connector after removing the multi flow. (Pic-3)



Picture-3

1. Remove the fan cover by flexing the fan cover detail and then remove the fan motor by flexing the fan motor rubbers. (Pic-1/ Pic-2/Pic-3)



Picture-1



Picture-2



Picture-3

2. Place the rubbers to the fan motor. After that, first place the bottom two details of the fan motor and place the top two details by pressing-flexing it. (Pic-4/ Pic-5/Pic-6)

Note : *The fan motor cable outlet should be at the top-left corner of it.*

3. After the connector is connected, place it by flexing it and then reassemble the multi flow by screwing.



Picture-4



Picture-5



Picture-6

1. Stick a tape to protect plastic. Insert a flat screwdriver into the gap and remove the cover. (Pic-1)



Picture-1

2. Remove the led strip light from its housing. (Pic-2)



Picture-2

3. Disconnect the connector and change the led light strip. (Pic-3)

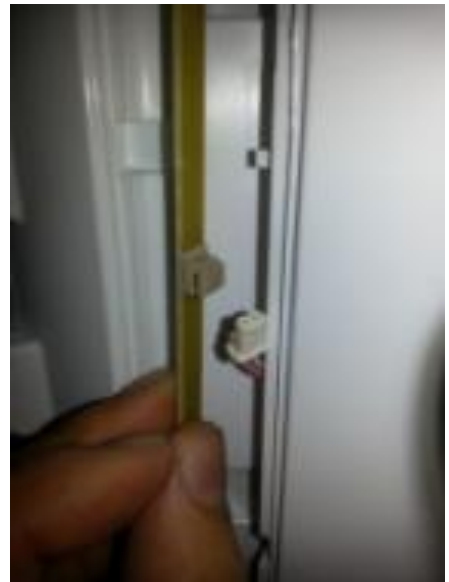

Picture-3

4. First, place the bottom point of the led light strip and then place towards other side.(Pic-4)



Picture-4

5. Reassemble the led cover. (Pic-5)



Picture-5

Changing The Cooler Sensor

1. Remove the sensor cover with the help of a screwdriver and then disconnect the sensor connector. (Pic-1)



Picture-1

2. Place the bottom-front details of the cover to its housing and then place the top cover detail to the housing by flexing it with a screwdriver. (Pic-2)



Picture-2

CAUTION: Pay attention not to damage to the sensor cover details!

Removing The Freezer Multi Flow Group

1. Displace the glass shelf or the ice box group if there is. (Pic-1)
2. Insert a flat screwdriver into the gap and then support the lateral surface of the multi flow with the help of a hand and remove the freezer multi flow group. (Pic-2)
3. Removing the freezer bottom cover. (Pic-3)



Picture-1



Picture-2



Picture-3

Assembling The Freezer Multi Flow Group

1. Recline the bottom cover against one side and place the freezer multi flow cover details. (Pic-4)
2. Hold the back side of the bottom cover and flex it. After that, reassemble the other side details. Finish the assembly by pulling the cover. (Pic-5 / Pic-6)
3. First, place the freezer multi flow details to the backside of the bottom cover (Pic-7/Pic-8) and reassemble the freezer multi flow cover by pushing back. (Pic-9)

Note: The freezer multi flow should be removed before the freezer bottom cover.



Picture-4



Picture-5



Picture-6



Picture-7



Picture-8



Picture-9

Removing Fin Evaporator Group

1. Remove the fin evaporator resistance connectors from the sockets. (Pic-1) (**blue** connector)

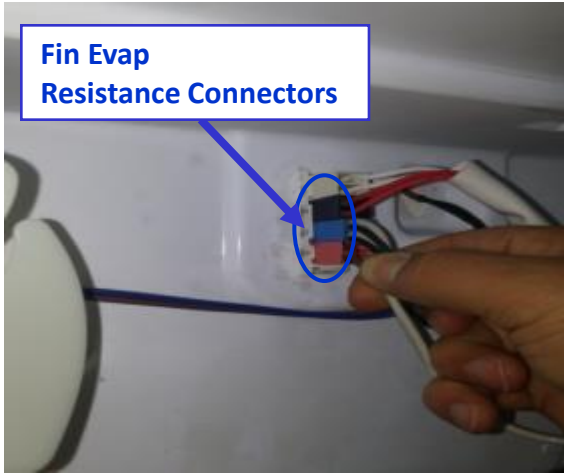

Picture-1

2. Displace the fin evaporator balanced by holding on both sides. (Pic-2)



Picture-2

CAUTION: The fin evaporator should not be pulled upward-downward. Otherwise, the fin evaporator fixing plastics might be broken.

Removing The Thermal Fuse

1. Remove the thermal fuse connector. (Pic-1) (**white-black** connector)

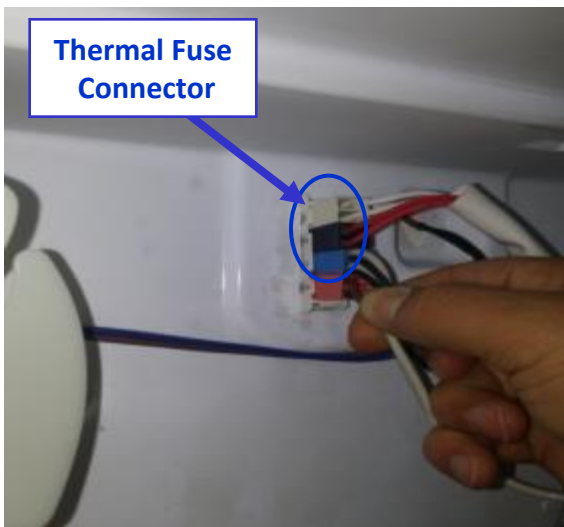

Picture-1

2. Thermal fuse has two details. These details hold on to the pipe. It could be removed easily. (Pic-2)



Picture-2

CAUTION: The plug must be pulled out before the mainboard group is removed.

1. Remove the putty around the freezer defrost sensor. (Pic-1)



Picture-1

2. Disconnect the sensor connector. (Pic-2)



Picture-2

3. Assemble the new sensor to the evaporator resistance as shown in the picture. (Pic-3)



Picture-3

4. Connect the sensor socket and apply putty. (Pic-4)



Picture-4

Removing The Freezer Fan Motor

1. Remove the fan motor connector. (Pic-1)
2. Unscrew the fan motor fixing screws and displace the fan motor. (Pic-2)
3. Remove the propeller. (Pic-3)



Picture-1



Picture-2



Picture-3

4. Displace the details on the fan motor box. (Pic-4)



Picture-4



Fan Motor Components

1. Unscrew the bottom tray screws and displace it from the compressor basement. After that, remove the fan motor connector. (Pic-1)
2. Unscrew the screws fixing the evaporating tray. (Pic-2)
3. Remove the evaporating tray to displace the fan motor. (Pic-3)



Picture-1



Picture-2



Picture-3

4. Unscrew the fan motor screws. (Pic-4)
5. Remove the propeller. (Pic-5,Pic-6)



Picture-4



Picture-5

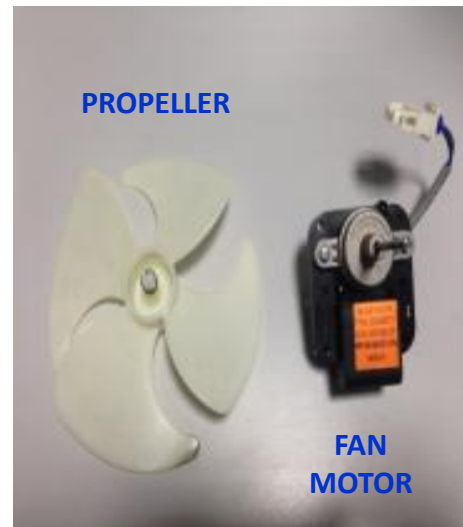

Picture-6

Removing/Assembling The Reed Switch

Take the reed switch out of its place with a screwdriver. Then Disconnect the connectors of the Switch and remove it.



Cabinet



Top door

NOTE: Reed Switch is a very sensitive miniature electronic card. So during the assembly and disassembly be careful not to damage it.

During the disassembly of the reed switch, there is a step on the edge of the plastic part which provides easier disassembly and by that tool it can be taken out from the same place every time.

It must be assembled as this step should be in the invisible (inside of the refrigerator) part. Otherwise the distance which the lamp turns on/off may change.

After the assembly or replacement the service should check if the reed switch is damaged by giving energy and opening and closing the door.