

DISHWASHER SERVICE MANUAL



A SERIES

CONTENTS

INFORMATION SHEET	3
INTERFACE AND HARDWARE	4
ELECTRICAL COMPONENTS	32
WATER HARDNESS SET	39
WASHING SPECIFICATIONS AND PROGRAMS	40
SERVICE FAILURE CODES	41
SETTING THE WATER HARDNESS	53
FAILURE CODES(POSSIBLE PROBLEMS)	54
BLDC MOTOR CONTROL SET	57
AUTOMATIC PROGRAM(TURBIDITY SENSOR)	58
NECESSARY INFORMATION WHILE INSTALLATING THE DISHWASHER	59
MEASURING COMPONENTS AND RESISTANCE VALUES	60
DISASSEMBLY	74

BARCODE STICKER CODE EXPLANATION / DISHWASHER:

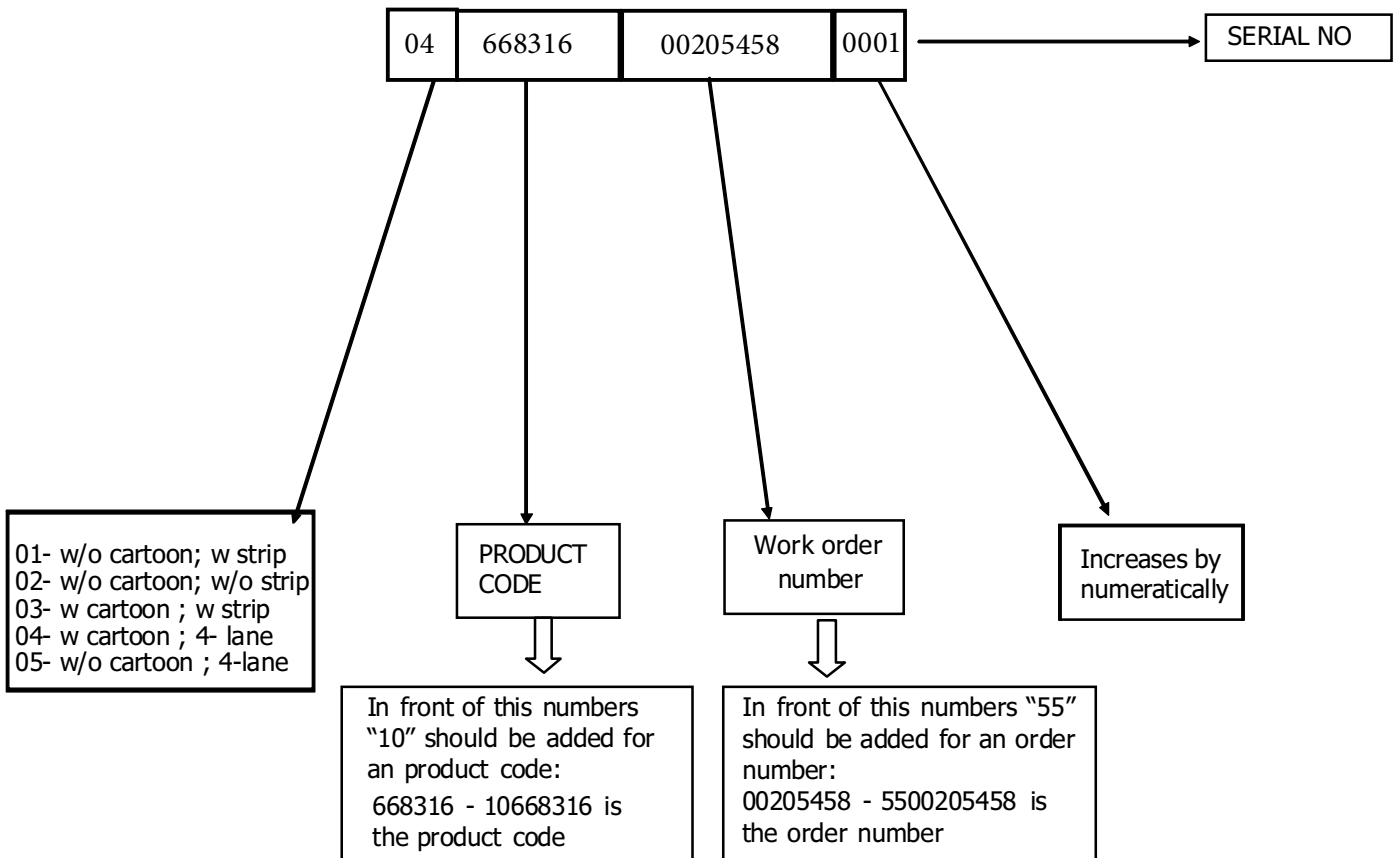

1. INTERFACE AND HARDWARE

1.1 A0 A SERIES W/O DISPLAY(A01,A02,A03,A04, A05, A06)

A01



A02



A03



A04



A05



A05



A0A

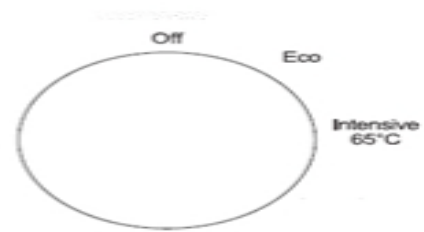

A0B

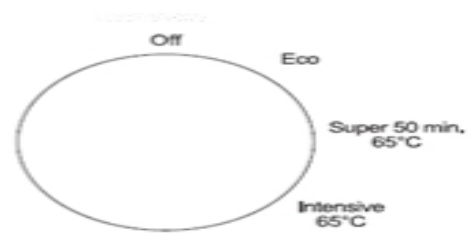

A0C

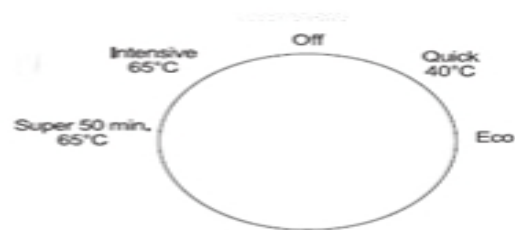

A0D

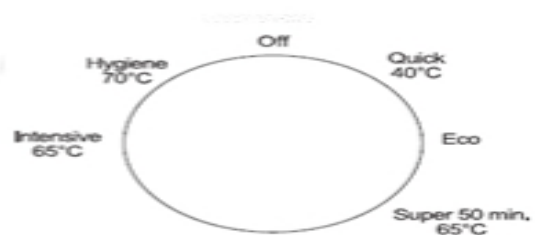

A0E

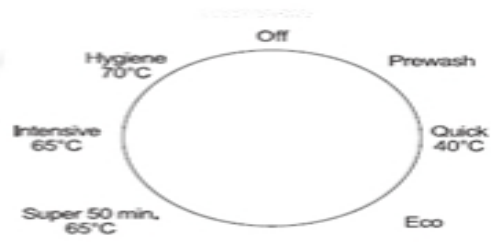

A0F

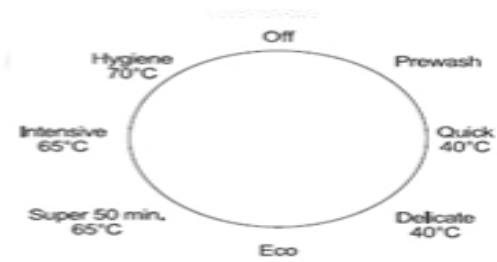

1.3 A SERIES W/O DISPLAY(A11, A12,A13,A14, A15)

- On/Off button with integrated led
- Up/down button
- Program leds
- Half Load button with integrated led(Half Load led)
- Tablet button with integrated led (Tablet led)
- Delay button
- Delay durations with 2 leds
- Rinse aid and Salt leds
- Child lock led
- Program status with Wash, Dry and End leds
- Start/Stop and Reset button with integrated led

A11



A12



A13



A14



A15

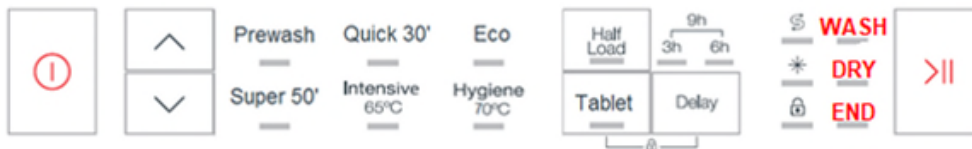

1.4 A SERIES W DISPLAY-W/O DIVERTER(A1A, A1B,A1C,A1D,A1E)

The user interface includes:

- On/Off button with integrated led
- Program button
- Program leds
- Delay button
- Rinse aid and Salt leds
- 888 display with “delay timer active” icon
- Program status with Wash, Rinse, Dry and End leds
- Start/Stop and Reset button with integrated led
- Half Load button with integrated led(Half Load led)
- Tablet button with integrated led (Tablet led)

Note: This must be done before turning on the machine.

VERSION 0 ((for Lily_VxRx1)

Models with “Lily” series.

A1A



A1B



A1C



A1D



A1E



VERSION 1 (for Lily1_VxRx1)
Models with display version Lily1 series.

A1A



A1B



A1C



A1D



A1E



1.3 A SERIES W/ DIVERTER(A21,A22,A23,A24,A25,A26)

The user interface includes:

- On/Off button with integrated led
- Program button
- Program leds
- Delay button
- Rinse aid and Salt leds
- 888 display with “delay timer active” icon
- Program status with Wash, Rinse, Dry and End leds
- Start/Stop and Reset button with integrated led
- Half Load button with integrated led(Half Load led)
- Tablet button with integrated led (Tablet led)

A21



A22

Programs	Prewash		Options
Delay	Quick 30' Delicate 40°C		Select
	Daily Super 65°C Intensive 65°C		

A23

Programs	Prewash Quick 30'		Options
Delay	Eco Daily Super 65°C		Select
	Auto Delicate Auto Normal Auto Intensive		

A24

Programs	Jetwash 14' Quick 30'		Options
Delay	Eco Dual Pro Wash Super 65°C		Select
	Auto Delicate Auto Normal Auto Intensive		

A25

Programs	Jetwash 14' Quick 30'		Options
Delay	Eco Eco 5.4 lt Dual Pro Wash		Select
	Super 65°C Auto Delicate Auto Intensive		

A26

Programs	Jetwash 14' Quick 30'		Options
Delay	Eco Dual Pro Wash Super 65°C		Select
	Auto Delicate Auto Normal Auto Intensive		

1.4 A SERIES W/ DIVERTER(A31,A32,A33,A34,A35,A36)

The user interface includes:

- On/Off button
- Program button
- Program icons
- Delay button
- Rinse aid and Salt icons
- 888 display
- “delay timer active” icon
- Program status with Wash, Rinse, Dry and End icons
- Start/Stop and Reset button
- Option button
- Select button





1.5 A SERIES W/ DIVERTER and FULL TOUCH DISPLAY(A41,A42,A43,A44,A45)

The user interface includes:

- On/Off touch button
- Program touch icons
- Delay touch button
- Energy Save touch icon(if available)
- Rinse aid and Salt icons
- 888 display
- “delay timer active” icon
- Program status with Wash, Rinse, Dry and End icons
- Start/Stop and Reset touch button
- Option touch buttons
- Energy and water consumption status icons

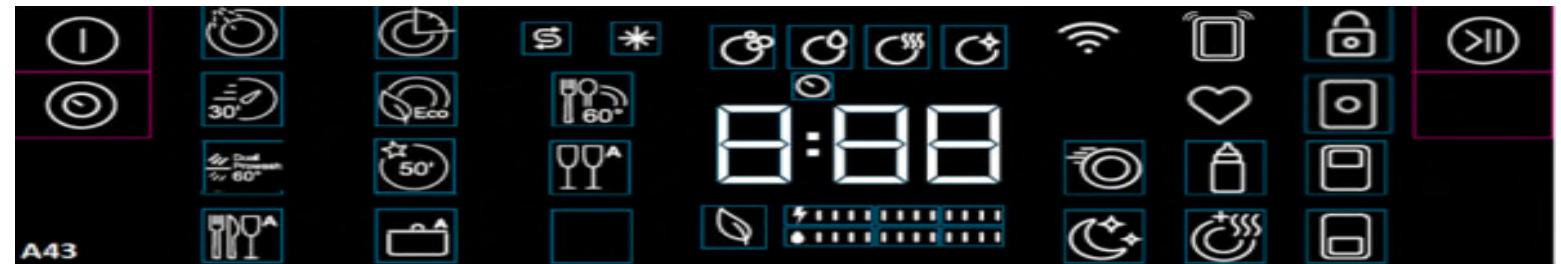
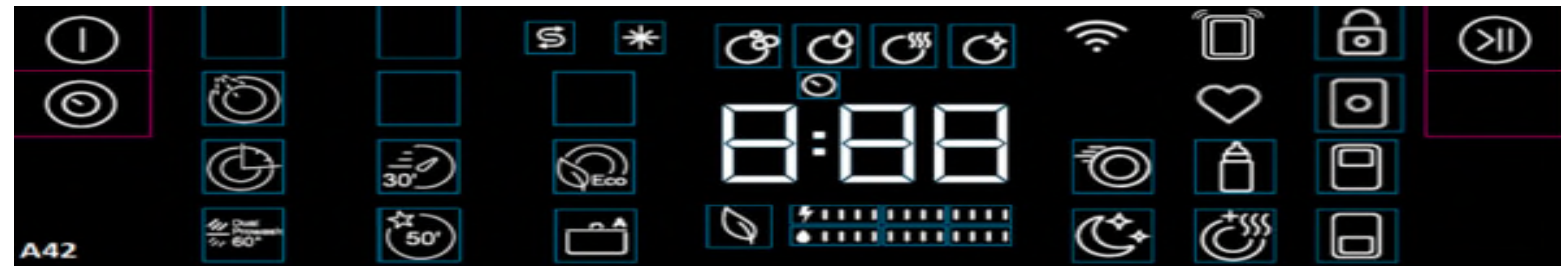
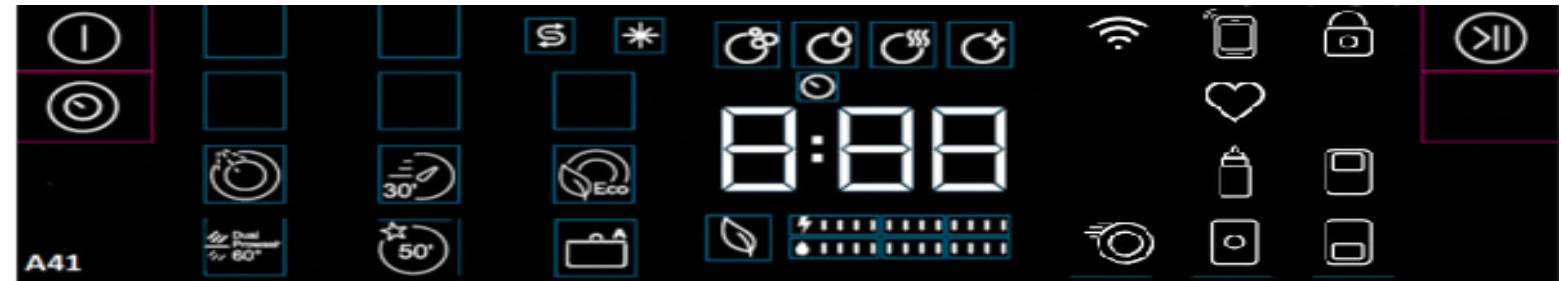

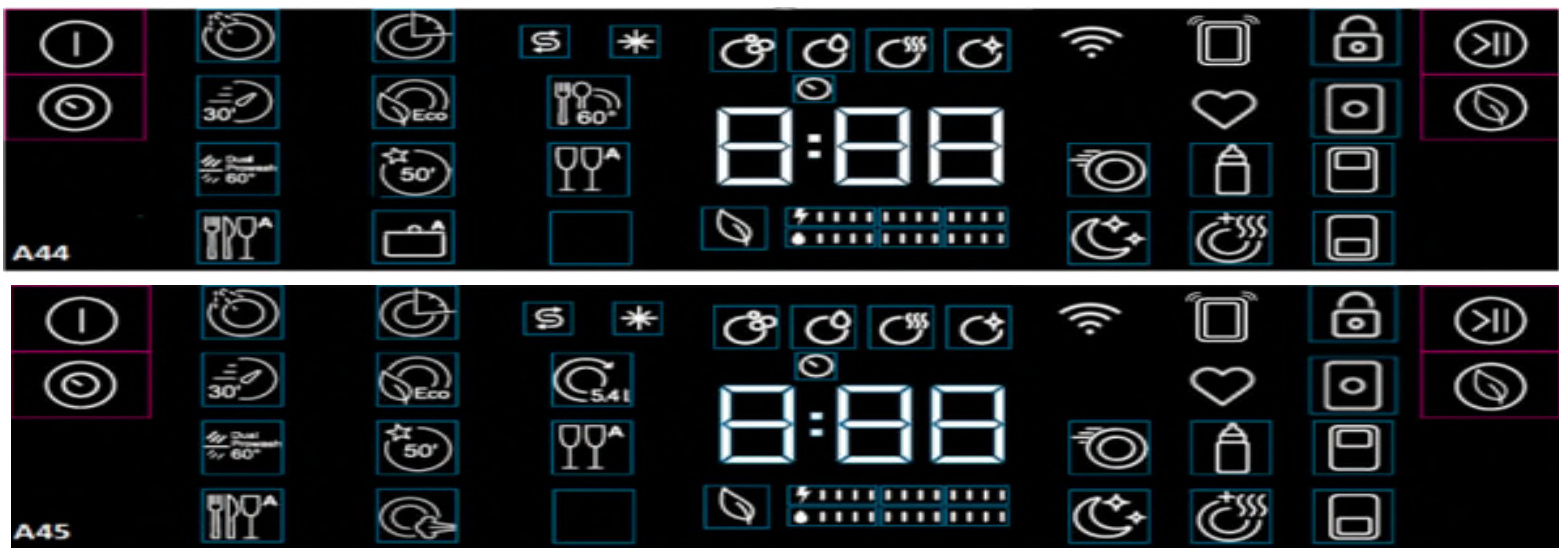

Display of the A4 indicator Energy and water bar



Prew	Jet1 8	Quick30	Eco	Eco 5,4lt	Sup 50	Daily	Dual Pro W	A./Delicete	A./Normal	A./Intensive	Steam
1	2	2	3	4	5	5	5	4	5	8	7
1	2	4	3	2	4	5	5	6	7	8	7

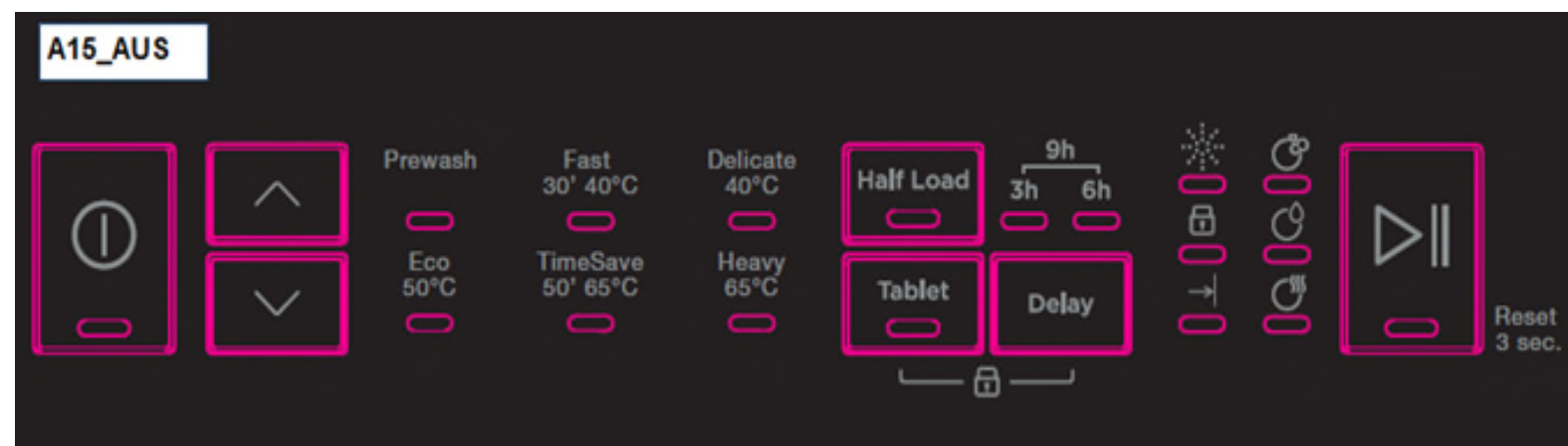

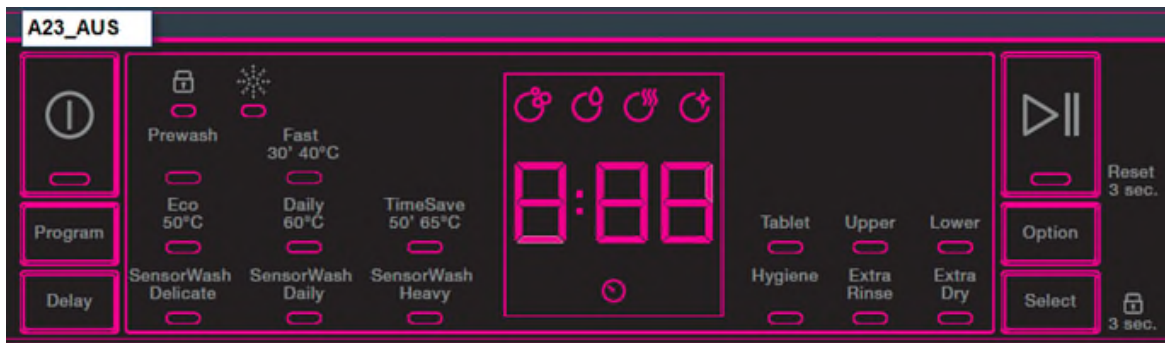

2. WASHING PROGRAM

2.1 WASHING PROGRAM CROSS TABLE

MODEL	PREWASH	JETWASH 14'	QUICK 30'	ECO 50 °C	Eco 5.4 lt	SUPER 50' 65 °C	DELICATE 40°C	INTENSIVE 65°C	AUTO	DAILY 60°C	DUAL PRO WASH 60°C	HYGIENE 70°C	AUTO DELICATE	AUTO NORMAL	AUTO INTENSIVE	STEAM WASH
A01-A0A				X				X								
A02-A0B				X		X		X								
A03-A0C			X	X		X		X								
A04-A0D			X	X		X		X				X				
A05-A0E	X		X	X		X		X				X				
A06-A0F	X		X	X		X	X	X				X				
A11-A1A				X				X								
A12-A1B				X		X		X								
A13-A1C			X	X		X		X								
A14-A1D			X	X		X		X				X				
A15-A1E	X		X	X		X		X				X				
A15_AUS	X		X	X		X	X	X								
A21	X		X	X		X	X	X	X							
A21_AUS	X		X	X		X	X	X	X							
A22	X		X	X		X	X	X	X	X						
A23	X		X	X		X				X			X	X	X	
A23_AUS	X		X	X		X				X			X	X	X	
A24		X	X	X		X					X		X	X	X	
A25		X	X	X	X	X					X		X		X	
A26		X	X	X		X					X		X	X	X	

A31	X	X	X	X		X								X	
A32	X	X	X	X		X						X	X	X	
A33		X	X	X		X				X				X	
A34		X	X	X		X				X		X	X	X	
A35		X	X	X	X	X				X		X	X	X	
A36		X	X	X		X				X		X	X	X	
A41	X		X	X		X				X				X	
A42	X	X	X	X		X				X				X	
A43	X	X	X	X		X			X	X		X	X	X	
A44	X	X	X	X		X			X	X		X	X	X	
A45	X	X	X	X	X	X				X		X	X		X

2.2 PROGRAMME SEQUENCES

Programme Number	A01-A0A	A02-A0B	A03-A0C	A04-A0D	A05-A0E	A06-A0F
P1	Eco 50°C	Eco 50°C	Quick 30'	Quick 30'	Prewash	Prewash
P2	Intensive 65°C	Super 50'	Eco 50°C	Eco 50°C	Quick 30'	Quick 30'
P3	-	Intensive 65°C	Super 50'	Super 50'	Eco 50°C	Delicate 40°C
P4	-	-	Intensive 65°C	Intensive 65°C	Super 50'	Eco 50°C
P5	-	-	-	Hygiene 70°C	Intensive 65°C	Super 50'
P6	-	-	-	-	Hygiene 70°C	Intensive 65°C
P7	-	-	-	-	-	Hygiene 70°C

Programme Number	A11-A1A	A12-A1B	A13-A1C	A14-A1D	A15-A1E	A15_AUS
P1	Eco 50°C	Eco 50°C	Quick 30'	Quick 30'	Prewash	Prewash
P2	Intensive 65°C	Super 50'	Eco 50°C	Eco 50°C	Quick 30'	Quick 30'
P3	-	Intensive 65°C	Super 50'	Super 50'	Eco 50°C	Delicate
P4	-	-	Intensive 65°C	Intensive 65°C	Super 50'	Eco
P5	-	-	-	Hygiene 70°C	Intensive 65°C	Süper 50'
P6	-	-	-	-	Hygiene 70°C	Yoğun

Programme Number	A21 A21_AUS	A22	A23 A23_AUS	A24	A25	A26
P1	Prewash	Prewash	Prewash	Jetwash 14'	Jetwash 14'	Jetwash 14'
P2	Quick 30'	Quick 30'	Quick 30'	Quick 30'	Quick 30'	Quick 30'
P3	Delicate 40°C	Delicate 40°C	Eco 50°C	Eco 50°C	Eco 50°C	Eco 50°C
P4	Eco 50°C	Eco 50°C	Daily 60°C	Dual Prowash	Eco 5,4 lt	Dual Prowash

P5	Super 50'	Daily 60°C	Super 50'	Super 50'	Dual Prowash	Super 50'
P6	Intensive 65°C	Super 50'	Auto Delicate	Auto Delicate	Super 50'	Auto Delicate
P7	-	Intensive 65°C	Auto Normal	Auto Normal	Auto Delicate	Auto Normal
P8	-	-	Auto Intensive	Auto Intensive	Auto Intensive	Auto Intensive

Programme Number	A31	A32	A33	A34	A35	A36
P1	Prewash	Prewash	Jetwash 14'	Jetwash 14'	Jetwash 14'	Jetwash 14'
P2	Jetwash 14'	Jetwash 14'	Quick 30'	Quick 30'	Quick 30'	Quick 30'
P3	Quick 30'	Quick 30'	Eco 50°C	Eco 50°C	Eco 50°C	Eco 50°C
P4	Eco 50°C	Eco 50°C	Dual Prowash	Dual Prowash	Eco 5.4 lt	Dual Prowash
P5	Super 50'	Super 50'	Super 50'	Super 50'	Dual Prowash	Super 50'
P6	Auto Intensive 60°C - 70°C	Auto Delicate	Auto Intensive 60°C - 70°C	Auto Delicate	Super 50'	Auto Delicate
P7	-	Auto Normal	-	Auto Normal	Auto Delicate	Auto Normal
P8	-	Auto Intensive	-	Auto Intensive	Auto Intensive	Auto Intensive

Programme Number	A41	A42	A43	A44	A45
P1	Prewash	Prewash	Prewash	Prewash	Prewash
P2	Quick 30'	Jetwash 14'	Jetwash 14'	Jetwash 14'	Jetwash 14'
P3	Eco 50°C	Quick 30'	Quick 30'	Quick 30'	Quick 30'
P4	Dual Prowash	Eco 50°C	Eco 50°C	Eco 50°C	Eco 50°C
P5	Super 50'	Dual Prowash	Daily 60°C	Daily 60°C	Eco 5.4 lt
P6	Auto Intensive 60°C - 70°C	Super 50'	Dual Prowash	Dual Prowash	Dual Prowash
P7	-	Auto Intensive 60°C - 70°C	Super 50'	Super 50'	Super 50'
P8	-	-	Auto Delicate	Auto Delicate	Auto Delicate
P9	-	-	Auto Normal	Auto Normal	Auto Normal
P10	-	-	Auto Intensive	Auto Intensive	Steam Wash

3. WASHING SPECIFICATIONS AND PROGRAMS

3.1 SELECTING AND STARTING PROGRAM AT POWER ON(BEFORE PROGRAM STARTS)

When the dishwasher is switched on,

- Firstly, when the power is turned ON and the machine is energized, all led + digits should remain lit until the program information (ready position or any other situation, step) remains on the display (A1, A2, A3, A4).

For models w/o display;

COMMANDS	On/Off	Start/Stop	Wash	Dry	End
Switch on	ON	ON	OFF	OFF	OFF
Select program	ON	ON	OFF	OFF	OFF
Pressure of Start/Stop button	ON	OFF	ON	OFF	OFF

3.10 IF USER PRESSES ANY BUTTON(AT THE END OF PROGRAM)

For models w/o display;

COMMANDS	On/Off	Start/Stop	Wash	Dry	End
End of program	ON	OFF	OFF	OFF	ON
Selection of new program or pressed option	ON	ON	OFF	OFF	OFF
Pressure of Start/Stop button	ON	OFF	ON	OFF	OFF

-When user selects a program at the end of program, related program led and Start/Stop led are ON. If selected, related option led(s) is ON.

After pressing Start/Stop button Wash led is ON. If selected, related option led(s) is ON.

For models w/ display;

COMMANDS	On/Off	Start/Stop	Wash	Rinse	Dry	End	Digit
End of program	ON	OFF	OFF	OFF	OFF	ON	OFF
Selection of new program or pressed option	ON	ON	OFF	OFF	OFF	OFF	Duration of new program is shown
Pressure of Start/Stop button	ON	OFF	ON	OFF	OFF	OFF	Duration of new program

When user selects a program at the end of program, related program duration is shown on the display. If selected, related option led is ON.

After pressing Start/Stop button, program starts and Wash led is ON. If selected, related option led(s) is ON.

3.11 MODIFICATION OF A PROGRAM WITHOUT RESET

The program continues with the flow program but with the parameters (temperature, times) of the new program. In heating step: If temperature is over than the new desired temperature, cut off heating step and go on with the next step with new parameters.

If temperature is lower than the new desired temperature heat up water to the desired temperature level.

In washing step: If the washing duration is over than the washing duration of new program, cut off washing step and go on with next step of new program.

If the washing duration is lower than the washing duration of new program, go on with washing step.

When new program is selected, display duration is changed to same step of new program.

For models w/o display;

COMMANDS	On/Off	Start/Stop	Wash	Dry	End
Washing cycle is in progress	ON	OFF	ON/OFF	ON/OFF	OFF
Pressure of Start/Stop button	ON	Blink	ON/OFF	ON/OFF	OFF
Select new program	ON	Blink	ON/OFF	ON/OFF	OFF
Pressure of Start/Stop button	ON	OFF	ON/OFF*	ON/OFF*	OFF

If user selects new program, related new program led is ON.

*Program continues with the new parameters and related washing led is ON.

For models w/ display;

COMMANDS	On/Off	Start/Stop	Wash	Rinse	Dry	End	Digit
Washing cycle is in progress	ON	OFF	ON/OFF	ON/OFF	ON/OFF	OFF	Duration of program
Pressure of Start/Stop button	ON	Blink	ON/OFF	ON/OFF	ON/OFF	OFF	Duration of program
Select new program	ON	Blink	ON/OFF	ON/OFF	ON/OFF	OFF	duration of new program
Pressure of Start/Stop button	ON	OFF	ON/OFF*	ON/OFF*	ON/OFF*	OFF	Duration of new program

*If user presses Start/Stop button, program continues with the new parameters and related washing led is ON

3.12 MODIFICATION OF A PROGRAM WITH RESET

For models w/o display;

COMMANDS	On/Off	Start/Stop	Wash	Dry	End
Washing cycle is in progress	ON	OFF	ON/OFF	ON/OFF	OFF
Pressure of Start/Stop button 3"	ON	OFF	OFF	OFF	Blink
Drain of water	ON	OFF	OFF	ON	Blink
End of Drain	ON	OFF	OFF	OFF	ON*
Select new program	ON	ON	OFF	OFF	OFF

*During the cancellation process End led blinks. After cancelling is finished, and only end led, on/off led, salt/rinse aid lack leds(if salt/rinse aid tanks are empty) are on.

For models w/ display;

COMMANDS	On/Off	Start/Stop	Wash	Rinse	Dry	End	Digit
Washing cycle is in progress	ON	OFF	ON/OFF	ON/OFF	ON/OFF	OFF	Duration of program
Pressure of Start/Stop button 3"	ON	OFF	OFF	OFF	OFF	Blinks	Duration of program
Drain of water	ON	OFF	OFF	OFF	ON	Blinks	0:01
End of Drain	ON	OFF	OFF	OFF	OFF	ON	OFF
Select new program	ON	ON	OFF	OFF	OFF	OFF	duration of new program

- Display shows "0:01" during reset process.

Display is off and and only end led , on/off led, salt/rinse aid lack leds(if salt/rinse aid tanks are empty) are on at the end of the reset process

3.13 SWITCH OFF THE MACHINE DURING PROGRAM AND BEFORE STARTING PROGRAM

When user presses On/Off button in standby position, machine is changed to Power OFF position and all leds and display are OFF.

For models w/o display;

COMMANDS	On/Off	Start/Stop	Wash	Dry	End
Before starting program	ON	ON	OFF	OFF	OFF
Pressure of On/Off button	OFF	OFF	OFF	OFF	OFF

For models w/ display;

COMMANDS	On/Off	Start/Stop	Wash	Rinse	Dry	End	Digit
Before starting program	ON	ON	OFF	OFF	OFF	OFF	duration of program
Pressure of On/Off button	OFF	OFF	OFF	OFF	OFF	OFF	OFF

3.14 SWITCH OFF THE MACHINE DURING PROGRAM AND AFTER STARTING PROGRAM

When machine is changed to Power OFF position during program, all leds are OFF, display is OFF, Program is paused and all electrical components are stopped. After pressing On/Off button, machine is ON. Selecting any program does not affect the program flow of previously selected program. Therefore, previously selected program is resumed.

For models w/o display;

COMMANDS	On/Off	Start/Stop	Wash	Dry	End
Washing cycle is in progress	ON	OFF	ON/OFF	ON/OFF	OFF
Machine is "POWER OFF"	OFF	OFF	OFF	OFF	OFF
Machine is "POWER ON"	ON	OFF	ON/OFF	ON/OFF	OFF
Select new program*	ON	OFF	ON/OFF	ON/OFF	OFF
Pressure of Start/Stop button	ON	Blink	ON/OFF	ON/OFF	OFF

Pressure of Start/Stop button again	ON	OFF	ON/OFF	ON/OFF	OFF
-------------------------------------	----	-----	--------	--------	-----

*New program cannot be selected without pressing Start/Stop button.

For models w/ display;

COMMANDS	On/Off	Start/Stop	Wash	Rinse	Dry	End	Digit
Washing cycle is in progress	ON	OFF	ON/OFF	ON/OFF	ON/OFF	OFF	Duration of program
Machine is "POWER OFF"	OFF	OFF	OFF	OFF	OFF	OFF	OFF
Machine is "POWER ON"	ON	OFF	ON/OFF	ON/OFF	ON/OFF	OFF	Duration of program
Select new program*	ON	OFF	ON/OFF	ON/OFF	ON/OFF	OFF	Duration of new program
Pressure of Start/Stop button	ON	Blink	ON/OFF	ON/OFF	ON/OFF	OFF	Duration of new program
Pressure of Start/Stop button again	ON	OFF	ON/OFF	ON/OFF	ON/OFF	OFF	Duration of new program

*New program cannot be selected without pressing Start/Stop button. □

Note: If the washing step is Dry before machine is powered off, program ends after machine is powered on.

3.15 CANCELLING OF A PROGRAM (DURING DELAY TIME)

For models w/o display;

COMMANDS	On/Off	Start/Stop	Wash	Dry	End	Selected indicators (delay timer)	Related program led
Pressure of Start/Stop button for 3"	ON	ON	OFF	OFF	Blink	ON	ON
End of program	ON	OFF	OFF	OFF	ON*	OFF	OFF

While pressing the Start/Stop button for 3", selected indicator led(3h, 6h or both 3h and 6h) is ON and related program led is ON.

*During the cancellation process End led blinks. After cancelling is finished, only end led, salt/rinse aid lack leds(if salt/rinse aid tanks are empty) are on.

For models w/ display;

COMMANDS	On/Off	Start/Stop	Wash	Rinse	Dry	End	Digit
Pressure of Start/Stop button for 3"	ON	ON	OFF	OFF	OFF	Blinks	Delay duration
End of program	ON	OFF	OFF	OFF	OFF	ON*	OFF

While pressing the Start/Stop button for 3", delay duration is shown on display.

*During the cancellation process End led blinks and digit shows "0:01". At the end of cancelling, only end led, salt/rinse aid lack leds(if salt/rinse aid tanks are empty) are on.

3.16 MODIFICATION OF A PROGRAM DURING DELAY TIME

After selecting new program or same program and pressing Start/Stop button, Delay time resumes, does not start again.

NOTE: The delay icon is active when the delayed start is started.

For models w/o display;

COMMANDS	On/Off	Start/Stop	Selected indicators(delay timer)	Related program led
During delay time	ON	ON	ON	ON
Pressure of Start/Stop button	ON	Blink	ON	ON
Select new program	ON	Blink	ON	New program led is ON
Pressure of Start/Stop button	ON	ON	ON	New program led is ON

New program starts with delay which is selected before.

For models w/ display;

COMMANDS	On/Off	Start/Stop	Delay	Digit
During delay time	ON	ON	ON	Delay duration
Pressure of Start/Stop button	ON	Blink	ON	1 st Delay duration, 1 st duration of program are shown alternately
Select new program	ON	Blink	ON	1 st Delay duration, 1 st duration of new program are shown alternately
Pressure of Start/Stop button	ON	ON	ON	Delay duration

3.17 SWITCH OFF THE MACHINE DURING DELAY TIME

For all models:

When only delay timer is active;

* If Stand-by off-on is done; delay is cancelled

Namely, If user cuts the energy by On/Off button and then machine is powered ON; Machine is in standby position. Then if user selects new program and presses Start/Stop button, selected program starts without delay.

* If Power off-on occurs; delay continues.

Namely, If mains voltage is cut, power is off and then power is on; delay continues, Start/Stop led is ON and related delay led blinks twice

When Delay timer is active and then child lock is activated;

* Delay timer continues for both standby off-on and power off-on.

For models w/o display;

COMMANDS	On/Off	Start/Stop	Selected indicators(delay timer)
During delay time	ON	ON	ON
Standby off	OFF	OFF	OFF
Standby on	ON	ON	OFF
Select new program	ON	ON	OFF
Pressure of Start/Stop button	ON	OFF	OFF

For models w/ display;

COMMANDS	On/Off	Start/Stop	Delay icon	Digit
During delay time	ON	ON	ON	Delay duration
Mains voltage is cut(Power off)	OFF	OFF	OFF	OFF
Mains voltage is back(Power on)	ON	ON	ON	Delay duration blinks twice and then resumes
Select new program	ON	ON	ON	Delay duration
Pressure of Start/Stop button	ON	OFF	ON	1" Delay duration, 1" duration of new program are shown alternately

Note: When user selects delay time but does not presses Start/Stop button: if user switch off/on the machine, delay timer is cancelled and machine is on standby position.

Note: When user starts a programme with delay and activates child lock: if user switch off/on the machine or mains voltage is cut; both delay and child lock is active when machine is energized.

3.18 BUZZER BEHAVIOURS

For A1 and A2 models;

COMMANDS	Buzzer
Power On and Power Off	Short beep
Pressure of all buttons	cShort beep
During 3"count down	Short beep(in every second)
During canceling	Short beep(once in two seconds like T24 models)
End of program or cancellation	3*Long beep
Failure situation	2*Short beep+wait+2*Short beep+ ...
Invalid action	2*Short beep

4. POWER FAIL

- During a Delay Start: At the power on, program consumes the remaining time.
- During a Drain + Fill step: At the power on the program restarts the step to the beginning (with the drain).
- During a Wash step: At the power on the program consumes the remaining time.
- During a Heating step: At the power on the program continues heating up to the desired temperature. The time out for the heating restart to the beginning (water could be cold again).
- During a Dry step: At the power on the program ends.
- During the first two step of a salt regeneration cycle (60" REGVALVE = ON or 60" REGVALVE +DRAIN ON): At the power on washing program will continue.
- During the washing resin step at regeneration cycle: At the power on the program ends.

It is possible that the power fail occurred when a regeneration cycle is requested. If it occurs:

- During the first two step of a salt regeneration cycle (60" REGVALVE = ON or 60" REGVALVE +DRAIN ON): at the power on washing program will continue.

- After the first two step of a salt regeneration cycle: at the power on the washing program will end and the resin wash will be performed at the beginning of the next washing cycle.

After a Power Fail washing program re-starts without any delay if temp. is less than 45 C.

After a Power Fail washing program wait 8" before re-starts program if temp. is equal or more than 45 C.

4.1 STANDBY ON/OFF - POWER ON/OFF

	CL is active in standby position	Delay timer is active	CL+Delay timer are active
Standby Off	Machine turns off	Machine turns off	Machine turns off
Standby On	CL is cancelled	Delay timer is cancelled	CL+Delay timer are active
Power Off	Machine turns off	Machine turns off	Machine turns off
Power On	CL is cancelled	Delay timer is active	CL+Delay timer are active

While washing is being operated, CL(which is activated before) is not cancelled if standby or power off/on is done.

5. OPTIONS

5.1 OPTIONS & MODELS

-In case of Power fail during washing, options are stored in memory.

-When the machine is switched on again, the last selected options are active and washing must go on remaining.

-Due to Eco design requirements, each energized of the machine (by pressing ON/OFF) Eco program must be fixed as default, the options that are chosen before will be cancelled.

- In case of Power fail, options are stored in memory if it occurs in washing cycle.
- For models with display; At the end of the program, when drain step is performed, only the third digit that is on the right of display will be ON. (It shows only one “0”). Then, when the users push any button, display shows the total time of the program).
- For all A models, each energized of the machine (by pressing ON/OFF), Eco program will be set as default setting. And the options that are chosen before (i.e: child lock, delay option etc...) will be cancelled.

For A0 models w/o diverter;

Option	A01-A0A	A02-A0B	A03-A0C	A04-A0D	A05-A0E	A06-A0F
Delay	X	X	X	X	X	X
Half load	X	X	X	X	X	X

For models w/o diverter;

Option	A12-A1B	A13-A1C	A14-A1D	A15-A1E
Delay	X	X	X	X
Half load	X	X	X	X
Tablet	X	X	X	X

For models w/ display-w/ diverter;

Option	A21	A22	A23	A24	A25	A26	A31 A32	A33 A34 A35	A36	A41	A42 A43	A44 A45
Delay	X	X	X	X	X	X	X	X	X	X	X	X
Half load(3 modes)	X	X	X	X	X	X	X	X	X	X	X	X
Tablet	X	X	X	X	X	X	X	X	X	X	X	X
Extra Hygiene	X	X	X	X	X	X	X	X	X	X	X	X
Extra Rinse	X	X	X	-	-	-	X	-	-	-	-	-
Extra Dry	X	X	X	-	-	X	X	-	X	-	X	X
Extra Silent	-	-	-	X	X	X	-	X	X	-	X	X
Extra Fast	-	-	-	X	X	X	-	X	X	X	X	X
Energy Save	-	-	-	X	X	-	-	X	-	-	-	X
Child Lock	X	X	X	X	X	X	X	X	X	X	X	X

5.2 COMPATIBILITY BETWEEN OPTIONS
For A1-A24-A25-A26-A3-A4

Options	Delay Timer	Half Load (3 modes)	Tablet	Child Lock	Extra Rinse	Extra Hygiene	Extra Dry	Energy save(Extra Drying for Y26)	Extra Fast	Extra Silent
Delay Timer		OK	OK	OK	OK	OK	OK	OK	OK	OK
Half Load (3 modes)	OK		OK	OK	OK	OK	OK	OK	OK	OK
Tablet	OK	OK		OK	OK	OK	OK	OK	OK	OK
Child Lock	OK	OK	OK		OK	OK	OK	OK	OK	OK
Extra Rinse	OK	OK	OK	OK		OK	OK	OK	OK	OK
Extra Hygiene	OK	OK	OK	OK	OK		-	OK	-	-
Extra Dry	OK	OK	OK	OK	OK	-		OK	OK	OK
Energy save(Extra Drying for Y26)	OK	OK	OK	OK	OK	OK	OK		OK	OK
Extra Fast	OK	OK	OK	OK	OK	-	OK	OK		-
Extra Silent	OK	OK	OK	OK	OK	-	OK	OK	-	

5.3 COMPATIBILITY BETWEEN OPTIONS & PROGRAMS.

A1 series	OPTIONS	Delay	Half Load	Tablet	Child Lock
PROGRAMS					
Prewash		X	-	-	X
Quick 30'		X	-	X	X
Eco 50°C		X	X	X	X
Super 50'		X	X	X	X
Intensive 65°C		X	X	X	X
Hygiene 70°C → yerine A15_AUS Delicate		X	X	X	X

Note: Half load option(with Prewash/Quick 30' program) cannot be selected for models without diverter.

Not: **Note: For A15_AUS, the current A15 Hygiene is replaced by DELICATE.**

A21 A22 Series	Delay	Half load(3 modes)	Tablet	Extra Hygiene	Extra Rinse	Extra Dry	Child Lock
Prewash	✗	✗	-	-	-	-	✗
Quick 30'	✗	✗	✗	-	✗	✗	✗
Delicate 40°C	✗	✗	✗	✗	✗	✗	✗
Eco 50°C	✗	✗	✗	✗	✗	✗	✗
Daily 60°C	✗	✗	✗	✗	✗	✗	✗
Super 50'	✗	✗	✗	✗	✗	✗	✗
Intensive 65°C	✗	✗	✗	✗	✗	✗	✗

A23 Series	Delay	Half load(3 modes)	Tablet	Extra Hygiene	Extra Rinse	Extra Dry	Child Lock
Prewash	X	X	-	-	-	-	X
Quick 30'	X	X	X	-	X	X	X
Eco 50°C	X	X	X	X	X	X	X
Daily 60°C	X	X	X	X	X	X	X
Super 50'	X	X	X	X	X	X	X
Auto Delicate	X	X	X	X	X	X	X
Auto Normal	X	X	X	X	X	X	X
Auto Intensive	X	X	X	X	X	X	X

A24 Series	Delay	Half load(3 modes)	Tablet	Extra Hygiene	Extra Silent	Extra Fast	Energy Save	Child Lock
Jetwash 14'	X	X	-	-	-	-	X	X
Quick 30'	X	X	X	-	-	-	X	X
Eco 50°C	X	X	X	X	X	X	X	X
Dual Prowash	X	X	X	X	X	X	X	X
Super 50'	X	X	X	X	-	-	X	X
Auto Delicate	X	X	X	X	-	-	X	X
Auto Normal	X	X	X	X	-	-	X	X
Auto Intensive	X	X	X	X	-	-	X	X

A25 Series	Delay	Half load(3 modes)	Tablet	Extra Hygiene	Extra Silent	Extra Fast	Energy Save	Child Lock
Jetwash 14'	X	X	-	-	-	-	X	X
Quick 30'	X	X	X	-	-	-	X	X
Eco 50°C	X	X	X	X	X	X	X	X
Eco 5.4 lt	X	X	X	X	X	X	X	X
Dual Prowash	X	X	X	X	X	X	X	X
Super 50'	X	X	X	X	-	-	X	X
Auto Delicate	X	X	X	X	-	-	X	X
Auto Intensive	X	X	X	X	-	-	X	X

A26 Series	Delay	Half load(3 modes)	Tablet	Extra Hygiene	Extra Dry	Extra Silent	Extra Fast	Child Lock
Jetwash 14'	X	X	-	-	-	-	-	X
Quick 30'	X	X	X	-	X	-	-	X
Eco 50°C	X	X	X	X	X	X	X	X
Dual Prowash	X	X	X	X	X	X	X	X
Super 50'	X	X	X	X	X	-	-	X
Auto Delicate	X	X	X	X	X	-	-	X
Auto Normal	X	X	X	X	X	-	-	X
Auto Intensive	X	X	X	X	X	-	-	X

A31 A32 Series	Delay	Half load(3 modes)	Tablet	Extra Rinse	Extra Dry	Extra Hygiene	Child Lock
Prewash	✗	✗	-	✗	-	-	✗
Jetwash 14'	✗	✗	-	✗	-	-	✗
Quick 30'	✗	✗	✗	✗	✗	-	✗
Eco 50°C	✗	✗	✗	✗	✗	✗	✗
Super 50'	✗	✗	✗	✗	✗	✗	✗
Auto Delicate	✗	✗	✗	✗	✗	✗	✗
Auto Normal	✗	✗	✗	✗	✗	✗	✗
Auto Intensive	✗	✗	✗	✗	✗	✗	✗

A33 A34 Series	Delay	Half load(3 modes)	Tablet	Extra Hygiene	Extra Silent	Extra Fast	Energy Save	Child Lock
Jetwash 14'	✗	✗	-	-	-	-	✗	✗
Quick 30'	✗	✗	✗	-	-	-	✗	✗
Eco 50°C	✗	✗	✗	✗	✗	✗	✗	✗
Dual Prowash	✗	✗	✗	✗	✗	✗	✗	✗
Super 50'	✗	✗	✗	✗	-	-	✗	✗
Auto Delicate	✗	✗	✗	✗	-	-	✗	✗
Auto Normal	✗	✗	✗	✗	-	-	✗	✗
Auto Intensive	✗	✗	✗	✗	-	-	✗	✗

A35 Series	Delay	Half load(3 modes)	Tablet	Extra Hygiene	Extra Silent	Extra Fast	Energy Save	Child Lock
Jetwash 14'	✗	✗	-	-	-	-	✗	✗
Quick 30'	✗	✗	✗	-	-	-	✗	✗
Eco 50°C	✗	✗	✗	✗	✗	✗	✗	✗
Eco 5,4 It	✗	✗	✗	✗	✗	✗	✗	✗
Dual Prowash	✗	✗	✗	✗	✗	✗	✗	✗
Super 50'	✗	✗	✗	✗	-	-	✗	✗
Auto Delicate	✗	✗	✗	✗	-	-	✗	✗
Auto Intensive	✗	✗	✗	✗	-	-	✗	✗

A36 Series	Delay	Half load(3 modes)	Tablet	Extra Hygiene	Extra Dry	Extra Silent	Extra Fast	Child Lock
Jetwash 14'	✗	✗	-	-	-	-	-	✗
Quick 30'	✗	✗	✗	-	✗	-	-	✗
Eco 50°C	✗	✗	✗	✗	✗	✗	✗	✗
Dual Prowash	✗	✗	✗	✗	✗	✗	✗	✗
Super 50'	✗	✗	✗	✗	✗	-	-	✗
Auto Delicate	✗	✗	✗	✗	✗	-	-	✗
Auto Normal	✗	✗	✗	✗	✗	-	-	✗
Auto Intensive	✗	✗	✗	✗	✗	-	-	✗

A41 Series	Delay	Half load(3 modes)	Tablet	Extra Hygiene	Extra Fast	Child Lock
Prewash	✗	✗	-	-	-	✗
Quick 30'	✗	✗	✗	-	-	✗
Eco 50°C	✗	✗	✗	✗	✗	✗
Dual Prowash	✗	✗	✗	✗	✗	✗
Super 50'	✗	✗	✗	✗	-	✗
Auto Intensive	✗	✗	✗	✗	-	✗

A42 Series	Delay	Half load(3 modes)	Tablet	Extra Hygiene	Extra Dry	Extra Silent	Extra Fast	Child Lock
Prewash	X	X	-	-	-	-	-	X
Jetwash 14'	X	X	-	-	-	-	-	X
Quick 30'	X	X	X	-	X	-	-	X
Eco 50°C	X	X	X	X	X	X	X	X
Dual Prowash	X	X	X	X	X	X	X	X
Super 50'	X	X	X	X	X	-	-	X
Auto Intensive	X	X	X	X	X	-	-	X

A43 Series	Delay	Half load(3 modes)	Tablet	Extra Hygiene	Extra Dry	Extra Silent	Extra Fast	Child Lock
Prewash	X	X	-	-	-	-	-	X
Jetwash 14'	X	X	-	-	-	-	-	X
Quick 30'	X	X	X	-	X	-	-	X
Eco 50°C	X	X	X	X	X	X	X	X
Daily 60°C	X	X	X	X	X	-	-	X
Dual Prowash	X	X	X	X	X	X	X	X
Super 50'	X	X	X	X	X	-	-	X
Auto Delicate	X	X	X	X	X	-	-	X
Auto Normal	X	X	X	X	X	-	-	X
Auto Intensive	X	X	X	X	X	-	-	X

A44 Series	Delay	Half load(3 modes)	Tablet	Extra Hygiene	Extra Dry	Extra Silent	Extra Fast	Energy Save	Child Lock
Prewash	X	X	-	-	-	-	-		X
Jetwash 14'	X	X	-	-	-	-	-	X	X
Quick 30'	X	X	X	-	X	-	-	X	X
Eco 50°C	X	X	X	X	X	X	X	X	X
Daily 60°C	X	X	X	X	X	-	-	X	X
Dual Prowash	X	X	X	X	X	X	X	X	X
Super 50'	X	X	X	X	X	-	-	X	X
Auto Delicate	X	X	X	X	X	-	-	X	X
Auto Normal	X	X	X	X	X	-	-	X	X
Auto Intensive	X	X	X	X	X	-	-	X	X

A45 Series	Delay	Half load(3 modes)	Tablet	Extra Hygiene	Extra Dry	Extra Silent	Extra Fast	Energy Save	Child Lock
Prewash	X	X	-	-	-	-	-		X
Jetwash 14'	X	X	-	-	-	-	-	X	X
Quick 30'	X	X	X	-	X	-	-	X	X
Eco 50°C	X	X	X	X	X	X	X	X	X
Eco 5.4 lt	X	X	X	X	X	X	X	X	X
Dual Prowash	X	X	X	X	X	X	X	X	X
Super 50'	X	X	X	X	X	-	-	X	X
Auto Delicate	X	X	X	X	X	-	-	X	X
Auto Normal	X	X	X	X	X	-	-	X	X
Steam Wash	X	X	X	X	X	-	-	-	X

5.4.2. COMPATIBILITY BETWEEN OPTIONS & PROGRAMS (A45_x)

	Delay Start	Half Load (3 modes) or Triple&Direct wash	Tablet	Child Lock	Extra Fast	Extra Hygiene	Extra Silent	Extra Drying
Prewash	X	X	-	X	-	-	-	-
Mini 18'	X	X	-	X	-	-	-	-
Quick 30'	X	X	X	X	-	-	-	X
Eco 50°C	X	X	X	X	X	X	X	X
Eco 5.4lt	X	X	X	X	X	X	X	X
DUAL PRO WASH	X	X	X	X	X	X	X	X
Super 50'	X	X	X	X	-	X	-	X
Auto Intensive 60°/70°C	X	X	X	X	-	X	-	X
Auto Normal 50-60°C	X	X	X	X	-	X	-	X
Auto Delicate 30-50°C	X	X	X	X	-	X	-	X
Steam Wash	X	X	X	X	-	X	-	X

- All options can be selected with eco 5.4lt program. But, when any option is selected in eco 5.4lt program, software start economic 50C program with options that is selected instead of eco 5.4lt.

ELECTRICAL COMPONENTS

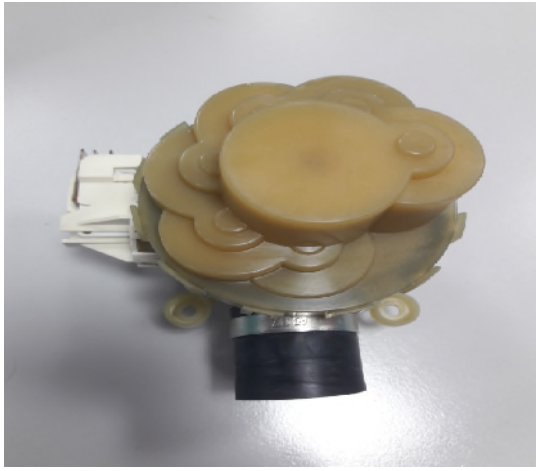

AQUAZONE

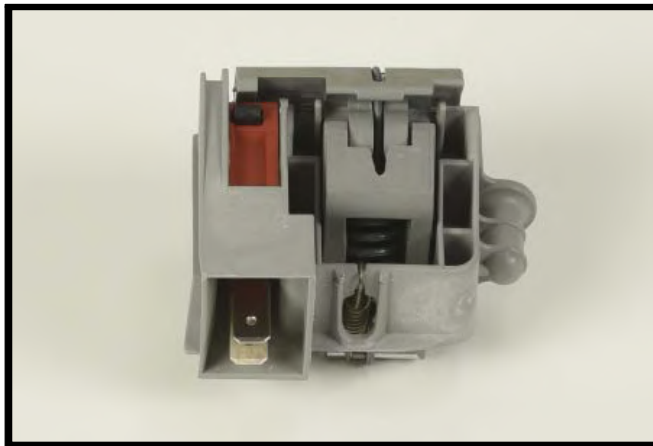

DOOR LOCK

It is a mechanical lock/release system that is closing the door, supplying the connection of electrical parts in the machine and cutting off the connection.

Currency 16 (4) A

CIRCULATION PUMP

Voltage	220/240
Frequency	50HZ
Total Power	90W
Coil Isolation Class	F
Thermal Protector	150°C
Pump Outlet Pressure	300mbar
Pump Flowrate	60 lt/min

Measurement of the primary windings of the washing pump. (118.2-135.9 Ω)

Measurement of the secondary windings of the washing pump (white cable – blue cable)(117.9-135.6 Ω)

Single direction, single phase, asynchronous and two pole.

It turns opposite clock direction.

It is assembled to the basement with rubber hangers.



FLOATER



CAPACITOR

2,5 μ F - 450 V class S2

Capacitor is permanently connected to the circulation pump coils.



DRAIN PUMP

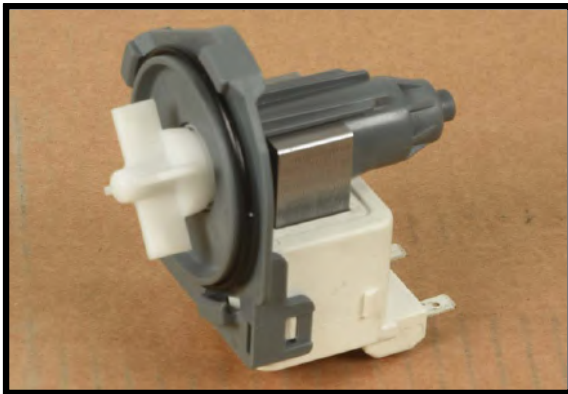

Voltage	220/240 volt
Frequency	50Hz
Flowrate	30W
Coil Resistance / Hanyu	220 Ω % \pm 7
Coil Resistance / Leili	141 Ω % \pm 7
Coil Isolation Class	F
Thermal Protector	120 $^{\circ}$ C

HEATER

Voltage 220/240 volt

Total power 1800W

27.6-30.6 ohm

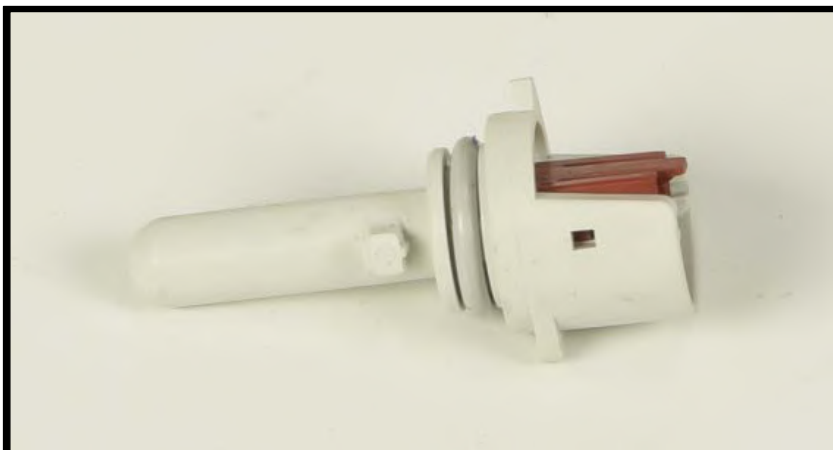
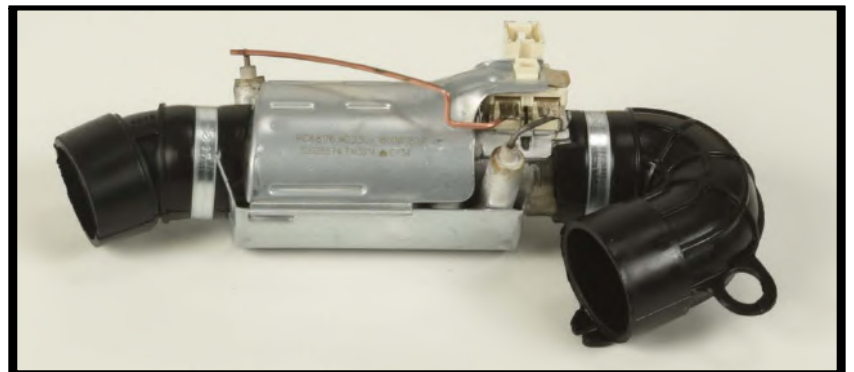

NTC

+25 $^{\circ}$ C	-	47.200	\pm	850	Ω
+30 $^{\circ}$ C	-	37.500	\pm	675	Ω
+40 $^{\circ}$ C	-	24.900	\pm	349	Ω
+50 $^{\circ}$ C	-	17.000	\pm	170	Ω
+60 $^{\circ}$ C	-	11.700	\pm	117	Ω
+70 $^{\circ}$ C	-	8.280	\pm	108	Ω
+80 $^{\circ}$ C	-	5.945	\pm	101	Ω

		C		T		
PRESSURE SWITCH	CN2.10 - CN2.2		0 Ω ∞Ω	KN2.9 - KN2.10		0 Ω ∞Ω
					WATER	NO WATER

PRESSURE SWITCH

Voltage 220/240 v

Frequency 50/60 Hz

16 A - 3 Pins

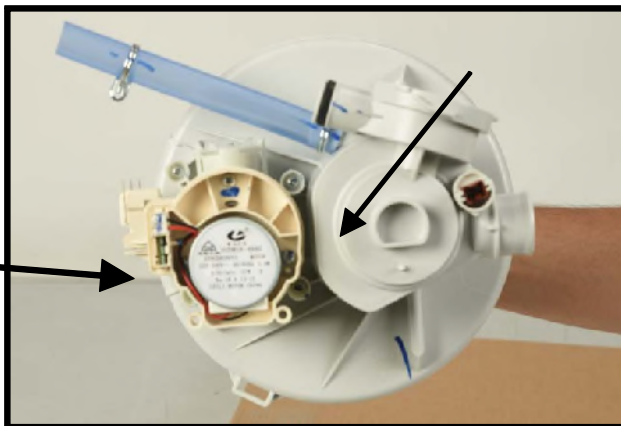
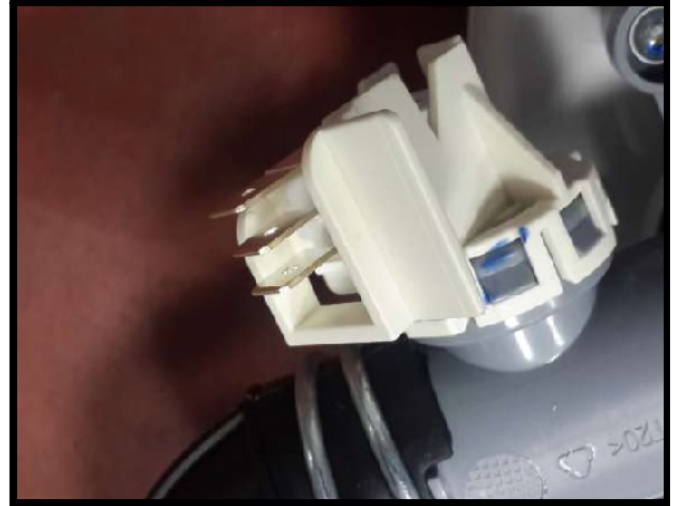

DIVERTER

There is diverter at A15 and A23 models It is assembled to the heater Casing Group.

Voltage	220/240 V
Frequency	50 Hz
Power	8W
Resistance	10500 ± %5 Ω

WATER INLET VALVE

Single inlet and single outlet standard single coil solenoid valve.

Voltage	220 - 240
Total Power	6W
Flowrate	2,5 ±% 15 lt/dk
Coil Isolation Class	H
Resistance	4200 ±%10



It is assembled to the basement and connect to the airbreak by hose.

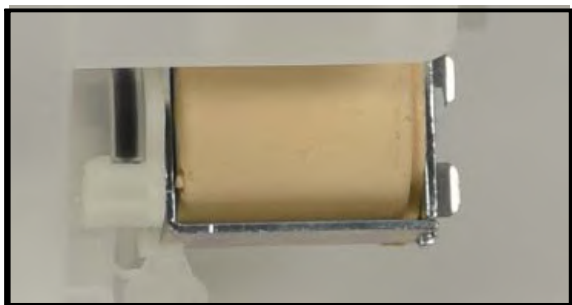

REGENERATION VALVE

Voltage	220/240 V
Frequency	50/60 Hz
Total power	6 W
Resistance	$3560 \pm \% 10 \Omega^{\circ}\text{C}$

Regeneration valve is assembled on the water softener.

PARASITE FILTER

Voltage	220/240
Frequency	50/60 Hz

$0,1 \mu\text{F} (\text{X1}) + 2 \times 2,2 \mu\text{F} (\text{Y2}) + 1\text{M}\Omega$

It is used to prevent parasites from the main supply It has been assembled to basement.

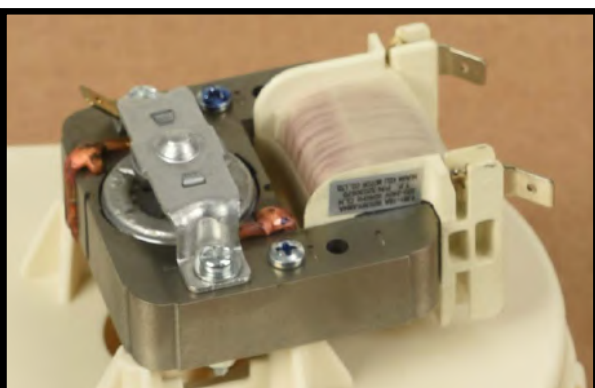
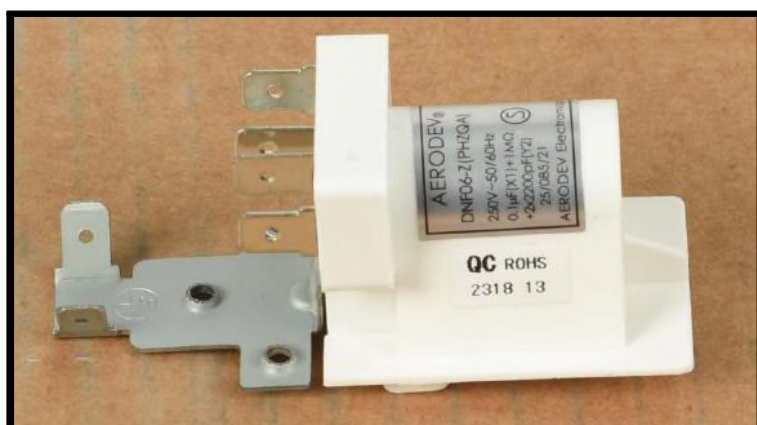

TURBO FAN MOTOR

There is a thermal protector shaded pole motor, two pole temperature is between $-40-150^{\circ}\text{C}$

There is turbo fan motor only at A models.

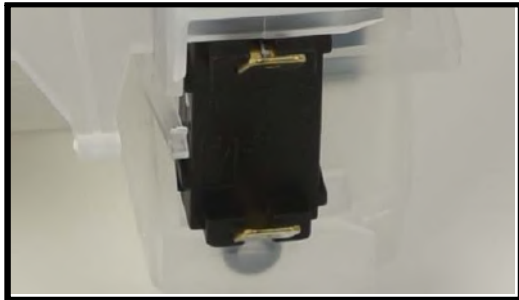

SALT SENSOR

Voltage	250 V
Current	50 mA



It is assembled to the water softener. It warns if the salt is less than requested quantity.

POWER CORD

Type	Euro 3'lü 1mm ² , copper conducting
Isolation	TS 9760 HO 5VV - F
Plug	TS - IEC 60884 - 1 PVC injected
Length	1650 mm

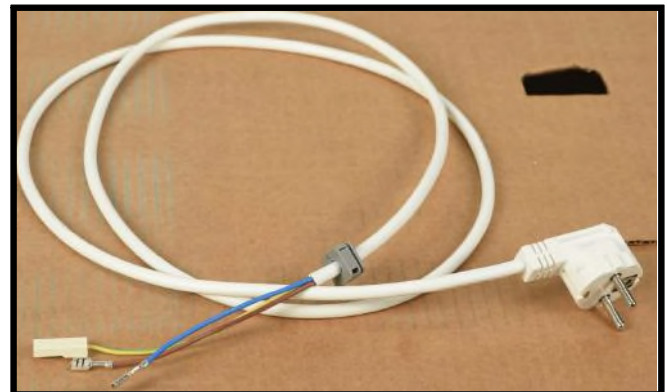

DRAIN HOSE



Drain hose maximum height	110 cm
Drain hose minimum height	50 cm
Drain hose maximum length	400 cm
Total Power	15 W
Voltage	220/240 V
Frequency	50 Hz
Resistance	238.6± %5 Ω



BLDC MOTOR

UPPER SPRAY ARM

It distributes water from upper spray arm to dirty dishes in the upper basket.

It provides to wash the dishes in the upper basket through turning by the holes with various angles.



LOWER SPRAY ARM

It distributes water from lower spray arm to dirty dishes in the lower basket.

It provides to wash the dishes in the lower basket through turning by the holes with various angles.



DETERGENT / RINSE AID DISPANSER

Detergant dispenser consists of rinse aid and detergent compartment. It has been assembled to the inner door by the snap fits. Only one bobbin has been used for operation the system.

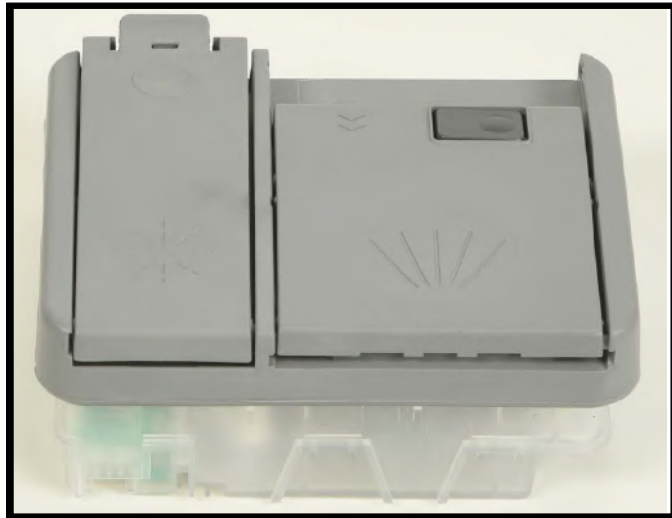

RINSE AID SET

In order to enter rinse aid set, user applies below steps.

- Power ON; press Up button at least for 5" for models without display
Power ON; press Program button at least for 5" for models with display. For A4 models, use delay button and press it for 5".
- If "Rinse aid set" is recognized;
all leds blink twice if model is without display. If model has display, "rA" is shown.
- Release program button. The last setting level is viewed*.
- Press program button to set the desired level.

At any pressure of program button rinse aid level is incremented. The level 1 returns after level 5. For models without display; rinse aid levels are the same with water hardness levels as shown in the table.

Level	Wash	Dry	End
1(0cc)	FIX	OFF	OFF
2(1,5cc)	OFF	FIX	OFF
3(3cc)	OFF	OFF	FIX
4(4,5cc)	FIX	FIX	OFF
5(6cc)	FIX	OFF	FIX

WATER HARDNESS SET

Only service can execute this procedure. This procedure erases the cycle counter. For AU Y models, water hardness level is level 1 as default.

Water Level	Hardness	German Hardness °dH	French hardness °dF	British hardness °dE	Water Liter
Level 1		0-5	0-9	0-6	-
Level 2		6-11	10-20	7-14	160lt
Level 3		12-17	21-30	15-21	89lt
Level 4		18-22	31-40	22-28	59lt
Level 5		23-31	41-55	29-39	46lt
Level 6		32-50	56-90	40-63	16lt

For models w/o display;

Power ON and press Up button at least for 3”.

If “Hardness set” is recognized all leds blink for 2”. This means that all leds blink once.

Release Up button. The last setting level is viewed*. Press Up button to increase press down button to decrease the level.

At any pressure of up button hardness level is increased. Hardness level 1 returns after hardness level 6. At any pressure of down button hardness level is decreased. Hardness level 6 returns after hardness level 1. If it is the first hardness set, hardness level is level 3.

Level	Wash	Dry	End
1	FIX	OFF	OFF
2	OFF	FIX	OFF
3	OFF	OFF	FIX
4	FIX	FIX	OFF
5	FIX	OFF	FIX
6	OFF	FIX	FIX

WASHING SPECIFICATIONS AND PROGRAMS

SELECTING AND STARTING PROGRAM AT POWER ON(BEFORE PROGRAM STARTS)

When the dishwasher is switched on,

For models w/o display;

COMMANDS	On/Off	Start/Stop	Wash	Dry	End
Switch on	ON	ON	OFF	OFF	OFF
Select program	ON	ON	OFF	OFF	OFF
Pressure of Start/Stop button	ON	OFF	ON	OFF	OFF

When user selects a program, related program led is ON. After pressing Start/Stop button, related program and wash led are ON. Note: When user always presses up button, first program follows last program. (ex: Program1-2-3-4-5-6-1-2-...)When user always presses down button, last program follows first program.(ex: Program 6-5-4-3-2-1-6-5-4-..)

SERVICE TEST

Only service can execute this procedure.

- Power OFF; press Start/Stop button.
- For all models: Power ON by pressing On/Off button and continue to press Start/Stop button at least for 6".
- When "Service test" is recognized
 - **For models w/o display:** All leds are ON.If model has sliding dispenser, all leds blink three times and service test starts.
 - **For models w/ display:** All leds are ON, SP is visualized on display and service test starts. During the first 6" of test, if a failure code is stored in memory, its codification blinks. Also at the end of the test if an error occurs its error code blinks.

During the test, SP is shown.

Step		Time	Tested Load
0	Show code	6"	Before start, the code of last error is visualized (see below)
1	Drain	6"	Drain pump.
2	Fill (3l/2,5l)*	~ 1'	Flow meter; Inlet Valve;
3	Fill + Wash (0,5/1l)**		Flow meter; Inlet Valve; Pressure Switch;
4	Turb. Sensor	30"	Measure of turbidity sensor
5	Wash	1'	Circulation pump; Regeneration Valve; detergent dispenser.
6	Wash + Heat ***	5'	Heater (PSW); NTC; diverter (position).
7/8	Reg. Valve + Turbo Fan	1'	Regeneration Valve + Turbo Fan
9	Water V+Drain	1'20"	Water Valve; Drain pump; Pressure switch
10	Drain	20"	Drain pump; pressure switch.
11	End	-	Code error or end led

* 3lt in A1; 2,5lt in A2.

** 0,5lt in A1; 1lt in A2.

*** In service test the unsuccessful heating failure routine works with reduced time of recognize (first measure at 2'20", second measure t 4'20")

If during the service test, the door is opened, Start/Stop led blinks (for models w/ display "SP" is shown).

If during the service test, the Start/Stop button is pressed, the program corresponding on the program leds(for models w/o display) or display(for models w/ display) position starts.

To reset the service test, press On/Off button or plug out and then plug in.

Also at the end of the test, if an error does not occur, any error code is not visualized. Machine will be standby position.

Note: If user did not set water hardness level before service test, "SE" is shown at the beginning and end of service test.

SERVICE FAILURE CODES

For models w/o display;

Name	S_P	Wash	Dry	End	display	Notes
Overflow/Leakage	-	Blink	-	Blink	F0/F1	In the normal work only leakage is visualized.
Drain time out	Blink	-	-	Blink	F2	
Presence Flow meter impulses	-	-	-	Blink	F3	
Absence Flow meter imp.	-	Blink	-	-	F4	In the normal work is not visualized.
Empty Level	Blink	-	-	-	F5	
Re-Fill time out	Blink	-	-	-	F5	
NTC ca/cc	Blink	Blink	-	-	F6	
Overheating	Blink	-	Blink	-	F7	
Unsuccessful heating	-	Blink	Blink	-	F8	In the normal work is visualized at the end of prg
Parameter set salt incorrect	Blink	Blink	-	Blink	SE	In the normal work this failure is not visualized.
CK Parameters	Blink	Blink	Blink	Blink	FE	
HIGH VOLTAGE	Blink	Blink	Blink	-	HI	
LOW VOLTAGE	-	Blink	Blink	Blink	LO	

For models w/ display;

Name	DISPLAY	Notes
Overflow	F0	In the normal work this failure is not visualized.
Leakage	F1	
Draining time out	F2	
Presence of Flow meter impulses	F3	
Absence of Flow meter	F4	In the normal work this failure is not visualized.
Empty Level	F5	
Re-Fill time out	F5	
NTC ca/cc	F6	
Overheating	F7	
Unsuccessful heating	F8	
Diverter opened	F9	
Turbidity Sensor	FA	In the normal work this failure is not visualized.
Parameter set salt incorrect	SE	In the normal work this failure is not visualized.
CK Parameter	FE	
High Voltage	HI	In the normal work this failure is not visualized.
Low Voltage	LO	In the normal work this failure is not visualized.

WASHING SPECIFICATIONS AND PROGRAMS

SELECTING AND STARTING PROGRAM AT POWER ON(BEFORE PROGRAM STARTS)

When the dishwasher is switched on,

For models w/o display;

COMMANDS	On/Off	Start/Stop	Wash	Dry	End
Switch on	ON	ON	OFF	OFF	OFF
Select program	ON	ON	OFF	OFF	OFF
Pressure of Start/Stop button	ON	OFF	ON	OFF	OFF

When user selects a program, related program led is ON. After pressing Start/ Stop button, related program and Wash led are ON.

Note: When user always presses up button, first program follows last program. (ex: Program1-2-3-4-5-6-1- 2-...)When user always presses down button, last program follows first program.(ex: Program 6-5-4-3-2-1- 6-5-4-..)

For models w/ display;

- The duration of the selected cycle is shown on the display.

COMMANDS	On/Off	Start/Stop	Wash	Rinse	Dry	End
Switch on	ON	ON	OFF	OFF	OFF	OFF
Select program	ON	ON	OFF	OFF	OFF	OFF
Pressure of Start/Stop button	ON	OFF	ON	OFF	OFF	OFF

- Default program is “Eco program”.

- When the dishwasher is powered off and on again in selection situation, the last executed program and options are not visualized on screen anymore. Every time machine is energized, Eco program is set as default.

OPENING AND CLOSING DOOR(BEFORE PROGRAM STARTS)

For models w/o display;

COMMANDS	On/Off	Start/Stop	Wash	Dry	End
Door open	ON	ON	OFF	OFF	OFF
Door closed	ON	ON	OFF	OFF	OFF

For models w/ display;

COMMANDS	On/Off	Start/Stop	Wash	Rinse	Dry	End
Door open	ON	ON	OFF	OFF	OFF	OFF
Door closed	ON	ON	OFF	OFF	OFF	OFF

OPENING AND CLOSING DOOR DURING PROGRAM(NOT IN DRY STEPS)

During the program if the door is opened and re-closed without any modifications on the program button and without the pressure of Start/Stop button, the program continues. Washing program re-starts after 8” if the measured temperature is equal or more than 45°C.

For models w/o display;

COMMANDS	On/Off	Start/Stop	Wash	Dry	End
Door open	ON	Blink	ON	OFF	OFF
Door closed	ON	OFF	ON	OFF	OFF

* When the door is opened, Washled is ON together with the blinking Start/Stop led.

For models w/ display;

COMMANDS	On/Off	Start/Stop	Wash	Rinse	Dry	End
Door open	ON	Blink	ON/OFF*	ON/OFF*	OFF	OFF
Door closed	ON	OFF	ON/OFF*	ON/OFF*	OFF	OFF

* **For models w/ display;**

- The duration of the selected cycle is shown on the display.

OPENING AND CLOSING DOOR DURING PROGRAM(IN DRY STEPS)

During dry step: if the door is opened and re-closed, the program is ended.

For models w/o display;

COMMANDS	On/Off	Start/Stop	Wash	Dry	End
Door open	ON	Blink	OFF	ON	OFF
Door closed	ON	OFF	OFF	OFF	ON

*When the door is opened, Dry led is ON together with the blinking Start/Stop led.

When the door is closed, program ends and End led is ON.

- Next, if user presses program or Start/Stop or delay button, machine is in standby position(last executed programme led and Start/Stop led are ON)
- Then, if user presses Start/Stop button, wash led is ON.

For models w/ display;

During dry step: if the door is opened and re-closed, the program is continued.

COMMANDS	On/Off	Start/Stop	Wash	Rinse	Dry	End
Door open	ON	Blink	OFF	OFF	ON	OFF
Door closed	ON	OFF	OFF	OFF	ON	OFF

OPENING AND CLOSING DOOR DURING PROGRAM(IN REGENERATION FIRST STEP)

During regeneration and resin washing step: if the door is opened and re-closed, the program continues.

For models w/o display;

COMMANDS	On/Off	Start/Stop	Wash	Dry	End
Door open	ON	Blink	OFF	ON	OFF
Door closed	ON	OFF	OFF	ON	OFF

*When the door is opened, Dry led is ON together with the blinking Start/Stop led.

When the door is closed, Dry led is

ON. For models w/ display;

COMMANDS	On/Off	Start/Stop	Wash	Rinse	Dry	End
Door open	ON	Blink	OFF	OFF	ON	OFF
Door closed	ON	OFF	OFF	OFF	ON	OFF

OPENING AND CLOSING DOOR DURING PROGRAM(IN REGENERATION SECOND STEP)

During regeneration and resin washing step: if the door is opened and re-closed, the program is ended.

For models w/o display;

COMMANDS	On/Off	Start/Stop	Wash	Dry	End
Door open	ON	Blink	OFF	ON	OFF
Door closed	ON	OFF	OFF	OFF	ON

*When the door is opened, Dry led is ON together with the blinking Start/Stop led.

When the door is closed, the program ends. Machine is in standby position(last executed programme led and Start/Stop led are ON)

For models w/ display;

COMMANDS	On/Off	Start/Stop	Wash	Rinse	Dry	End
Door open	ON	Blink	OFF	OFF	ON	OFF
Door closed	ON	OFF	OFF	OFF	OFF	ON

When the door is opened and re-closed, program ends and display shows 0:00”.

SELECTING AND STARTING PROGRAM WHEN DOOR IS OPENED(BEFORE PROGRAM STARTS)

For models w/o display;

COMMANDS	On/Off	Start/Stop	Wash	Dry	End
Switch on	ON	ON	OFF	OFF	OFF
Door open	ON	ON	OFF	OFF	OFF
Select program	ON	ON	OFF	OFF	OFF
Pressure of Start/Stop button	ON	Blink*	ON	OFF	OFF
Door closed	ON	OFF	ON	OFF	OFF

*If user presses Start/Stop button, Start/Stop led blinks and also related program led(s)is ON.

After closing the door, Wash led is ON and selected program starts.

For models w/ display;

COMMANDS	On/Off	Start/Stop	Wash	Rinse	Dry	End
Switch on	ON	ON	OFF	OFF	OFF	OFF
Door open	ON	ON	OFF	OFF	OFF	OFF
Select program	ON	ON	OFF	OFF	OFF	OFF
Pressure of Start/Stop button	ON	Blink*	ON	OFF	OFF	OFF
Door closed	ON	OFF	ON	OFF	OFF	OFF

If user selects a program when the door is open, related program duration is seen on the display. Then, if user presses Start/Stop button, duration of the selected program led blinks. After closing the door, Wash led is ON and selected program starts.

TERMINATION OF A PROGRAM(END OF PROGRAM)

For models w/o display;

COMMANDS	On/Off	Start/Stop	Wash	Dry	End
End of program	ON	OFF	OFF	OFF	ON
Door open	ON	OFF	OFF	OFF	ON
Door closed	ON	ON	OFF	OFF	OFF

When the door is closed, last executed program led and Start/stop led are ON. Namely, Machine is in standby position.

For models w/ display;

COMMANDS	On/Off	Start/Stop	Wash	Rinse	Dry	End	Digit
End of program	ON	OFF	OFF	OFF	OFF	ON	"0:00"
Door open	ON	OFF	OFF	OFF	OFF	ON	"0:00"
Door closed	ON	ON	OFF	OFF	OFF	OFF	duration of last executed program is shown

At the end of program, display shows 0:00.

CANCELLING OF A PROGRAM(DURING PROGRAM)

For models w/o display;

COMMANDS	On/Off	Start/Stop	Wash	Dry	End
Pressure of Start/Stop button 3"	ON	ON	OFF	OFF	Blink
End of program	ON	OFF	OFF	OFF	ON

While pressing the Start/Stop button for 3",End led blinks.After cancelling is finished, "End Led" is ON.

For models w/ display;

COMMANDS	On/Off	Start/Stop	Wash	Rinse	Dry	End	Digit
Pressure of Start/Stop button 3"	ON	ON	OFF	OFF	OFF	Blink	"0:01"
End of program	ON	OFF	OFF	OFF	OFF	ON	"0:00"

- Display shows "0:01" during cancelation process and End led blinks.
- Display shows 0:00 at the end of the cancelation process and End led is ON.

For both models with and without display:

If cancelling operation is paused, S/P led and end led blinks together.

IF USER PRESSES ANY BUTTON(AT THE END OF PROGRAM)

For models w/o display;

COMMANDS	On/Off	Start/Stop	Wash	Dry	End
End of program	ON	OFF	OFF	OFF	ON
Selection of new program or pressed option	ON	ON	OFF	OFF	OFF
Pressure of Start/Stop button	ON	OFF	ON	OFF	OFF

-When user selects a program at the end of program, related program led and Start/Stop led are ON. If selected, related option led(s) is ON.

After pressing Start/Stop button Wash led is ON. If selected, related option led(s) is ON.

For models w/ display;

COMMANDS	On/Off	Start/Stop	Wash	Rinse	Dry	End	Digit
End of program	ON	OFF	OFF	OFF	OFF	ON	0:00
Selection of new program or pressed option	ON	ON	OFF	OFF	OFF	OFF	Duration of new program is shown
Pressure of Start/Stop button	ON	OFF	ON	OFF	OFF	OFF	Duration of new program

When user selects a program at the end of program, related program duration is shown on the display. If selected, related option led is ON.

After pressing Start/Stop button, program starts and Wash led is ON. If selected, related option led(s) is ON.

MODIFICATION OF A PROGRAM WITHOUT RESET

The program continues with the flow program but with the parameters (temperature, times) of the new program. In heating step: If temperature is over than the new desired temperature, cut off heating step and go on with the next step with new parameters. If temperature is lower than the new desired temperature heat up water to the desired temperature level. In washing step: If the washing duration is over than the washing duration of new program, cut off washing step and go on with next step of new program. If the washing duration is lower than the washing duration of new program, go on with washing step. When new program is selected, display duration is changed to same step of new program.

For models w/o display;

COMMANDS	On/Off	Start/Stop	Wash	Dry	End
Washing cycle is in progress	ON	OFF	ON/OFF	ON/OFF	OFF

Pressure of Start/Stop button	ON	Blink	ON/OFF	ON/OFF	OFF
Select new program	ON	Blink	ON/OFF	ON/OFF	OFF
Pressure of Start/Stop button	ON	OFF	ON/OFF*	ON/OFF*	OFF

If user selects new program, related new program led is ON.

*Program continues with the new parameters and related washing led is ON.

For models w/ display;

COMMANDS	On/Off	Start/Stop	Wash	Rinse	Dry	End	Digit
Washing cycle is in progress	ON	OFF	ON/OFF	ON/OFF	ON/OFF	OFF	Duration of program
Pressure of Start/Stop button	ON	Blink	ON/OFF	ON/OFF	ON/OFF	OFF	Duration of program
Select new program	ON	Blink	ON/OFF	ON/OFF	ON/OFF	OFF	duration of new program
Pressure of Start/Stop button	ON	OFF	ON/OFF*	ON/OFF*	ON/OFF*	OFF	Duration of new program

*If user presses Start/Stop button, program continues with the new parameters and related washing led is ON

MODIFICATION OF A PROGRAM WITH RESET

For models w/o display;

COMMANDS	On/Off	Start/Stop	Wash	Dry	End
Washing cycle is in progress	ON	OFF	ON/OFF	ON/OFF	OFF
Pressure of Start/Stop button 3"	ON	OFF	OFF	OFF	Blink
Drain of water	ON	OFF	OFF	ON	Blink
End of Drain	ON	OFF	OFF	OFF	ON*
Select new program	ON	ON	OFF	OFF	OFF

*During the cancellation process End led blinks. After cancelling is finished, "End Led" is ON.

After the cancellation process, if user selects new program, related program led is ON.

For models w/ display;

COMMANDS	On/Off	Start/Stop	Wash	Rinse	Dry	End	Digit
Washing cycle is in progress	ON	OFF	ON/OFF	ON/OFF	ON/OFF	OFF	Duration of program

Pressure of Start/Stop button 3"	ON	OFF	OFF	OFF	OFF	Blinks	Duration of program
Drain of water	ON	OFF	OFF	OFF	ON	Blinks	0:01
End of Drain	ON	OFF	OFF	OFF	OFF	ON	0:00
Select new program	ON	ON	OFF	OFF	OFF	OFF	duration of new program

- Display shows "0:01" during reset process.
- Display shows "0:00" at the end of the reset process

SWITCH OFF THE MACHINE DURING PROGRAM AND BEFORE STARTING PROGRAM

When user presses On/Off button in standby position, machine is changed to Power OFF position and all leds and display are OFF.

For models w/o display;

COMMANDS	On/Off	Start/Stop	Wash	Dry	End
Before starting program	ON	ON	OFF	OFF	OFF
Pressure of On/Off button	OFF	OFF	OFF	OFF	OFF

For models w/ display;

COMMANDS	On/Off	Start/Stop	Wash	Rinse	Dry	End	Digit
Before starting program	ON	ON	OFF	OFF	OFF	OFF	duration of program
Pressure of On/Off button	OFF	OFF	OFF	OFF	OFF	OFF	OFF

SWITCH OFF THE MACHINE DURING PROGRAM AND AFTER STARTING PROGRAM

When machine is changed to Power OFF position during program, all leds are OFF, display is OFF, Program is paused and all electrical components are stopped. After pressing On/Off button, machine is ON. Selecting any program does not affect the program flow of previously selected program. Therefore, previously selected program is resumed.

For models w/o display;

COMMANDS	On/Off	Start/Stop	Wash	Dry	End
Washing cycle is in progress	ON	OFF	ON/OFF	ON/OFF	OFF
Machine is "POWER OFF"	OFF	OFF	OFF	OFF	OFF
Machine is "POWER ON"	ON	OFF	ON/OFF	ON/OFF	OFF
Select new program*	ON	OFF	ON/OFF	ON/OFF	OFF
Pressure of Start/Stop button	ON	Blink	ON/OFF	ON/OFF	OFF
Pressure of Start/Stop button again	ON	OFF	ON/OFF	ON/OFF	OFF

*New program cannot be selected without pressing Start/Stop button.

For models w/ display;

COMMANDS	On/Off	Start/Stop	Wash	Rinse	Dry	End	Digit
Washing cycle is in progress	ON	OFF	ON/OFF	ON/OFF	ON/OFF	OFF	Duration of program
Machine is "POWER OFF"	OFF	OFF	OFF	OFF	OFF	OFF	OFF
Machine is "POWER ON"	ON	OFF	ON/OFF	ON/OFF	ON/OFF	OFF	Duration of program
Select new program*	ON	OFF	ON/OFF	ON/OFF	ON/OFF	OFF	Duration of new program
Pressure of Start/Stop button	ON	Blink	ON/OFF	ON/OFF	ON/OFF	OFF	Duration of new program
Pressure of Start/Stop button again	ON	OFF	ON/OFF	ON/OFF	ON/OFF	OFF	Duration of new program

*New program cannot be selected without pressing Start/Stop button.

Note: If the washing step is Dry before machine is powered off, program ends after machine is powered on.

CANCELLING OF A PROGRAM (DURING DELAY TIME)

For models w/o display;

COMMANDS	On/Off	Start/Stop	Wash	Dry	End	Selected indicators (delay timer)	Related program led
Pressure of Start/Stop button for 3"	ON	ON	OFF	OFF	Blink	ON	ON
End of program	ON	OFF	OFF	OFF	ON*	OFF	OFF

While pressing the Start/Stop button for 3", selected indicator led(3h, 6h or both 3h and 6h) is ON and related program led is ON.

*During the cancellation process End led blinks. After cancelling is finished, "End Led" is ON.

For models w/ display;

COMMANDS	On/Off	Start/Stop	Wash	Rinse	Dry	End	Digit
Pressure of Start/Stop button for 3"	ON	ON	OFF	OFF	OFF	Blinks	Delay duration
End of program	ON	OFF	OFF	OFF	OFF	ON*	"0:00"

While pressing the Start/Stop button for 3”, delay duration is shown on display.

*During the cancellation process End led blinks and digit shows “0:01”. At the end of cancelling, End led is ON and digit shows “0:00”.

MODIFICATION OF A PROGRAM DURING DELAY TIME

After selecting new program or same program and pressing Start/Stop button, Delay time resumes, does not start again.

For models w/o display;

COMMANDS	On/Off	Start/Stop	Selected indicators(delay timer)	Related program led
During delay time	ON	ON	ON	ON
Pressure of Start/Stop button	ON	Blink	ON	ON
Select new program	ON	Blink	ON	New program led is ON
Pressure of Start/Stop button	ON	ON	ON	New program led is ON

New program starts with delay which is selected before.

For models w/ display;

COMMANDS	On/Off	Start/Stop	Delay	Digit
During delay time	ON	ON	ON	Delay duration
Pressure of Start/Stop button	ON	Blink	ON	1” Delay duration, 1” duration of program are shown alternately
Select new program	ON	Blink	ON	1” Delay duration, 1” duration of new program are shown alternately
Pressure of Start/Stop button	ON	ON	ON	Delay duration

SWITCH OFF THE MACHINE DURING DELAY TIME

For all models:

When only delay timer is active;

* If Stand-by off-on is done; delay is cancelled

Namely, If user cuts the energy by On/Off button and then machine is powered ON; Machine is in standby position. Then if user selects new program and presses Start/Stop button, selected program starts without delay.

* If Power off-on occurs; delay continues.

Namely, If mains voltage is cut, power is off and then power is on; delay continues, Start/Stop led is ON and related delay led blinks twice

When Delay timer is active and then child lock is activated;

* Delay timer continues for both standby off-on and power off-on.

For models w/o display;

COMMANDS	On/Off	Start/Stop	Selected indicators(delay timer)
During delay time	ON	ON	ON
Standby off	OFF	OFF	OFF
Standby on	ON	ON	OFF
Select new program	ON	ON	OFF
Pressure of Start/Stop button	ON	OFF	OFF

For models w/ display;

COMMANDS	On/Off	Start/Stop	Delay icon	Digit
During delay time	ON	ON	ON	Delay duration
Mains voltage is cut(Power off)	OFF	OFF	OFF	OFF
Mains voltage is back(Power on)	ON	ON	ON	Delay duration blinks twice and then resumes
Select new program	ON	ON	ON	Delay duration
Pressure of Start/Stop button	ON	OFF	ON	1" Delay duration, 1" duration of new program are shown alternately

Note: When user selects delay time but does not presses Start/Stop button: if user switch off/on the machine, delay timer is cancelled and machine is on standby position.

Note: When user starts a programme with delay and activates child lock: if user switch off/on the machine or mains voltage is cut; both delay and child lock is active when machine is energized.

SETTING THE WATER HARDNESS

TEST STRIP;

The washing effectiveness of your machine depends on the softness of the tap water. For this reason, your machine is equipped with a system that reduces the hardness in mains water supply. The washing effectiveness will increase when the system is correctly set. To make the system setting, use the testing strip, if it is available, and find the hardness of the mains water supply.

Open the testing strip.	Run water through your tap for 1 min.	Keep the testing strip in water for 1 sec.	Shake the testing strip after taking it out of water.	Wait for 1 min.	Make your machine's water hardness setting according to the result obtained through the testing strip.
-------------------------	---------------------------------------	--	---	-----------------	--

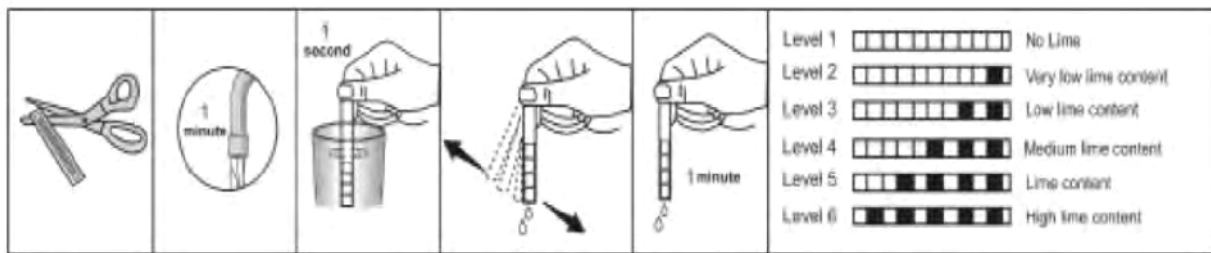

FAILURE CODES (Possible Problems)

F1 (ALARM IS ACTIVE FOR OVERFLOW)

FLOATER

- Floater switch can be out of order or have a problem with the cable connection.

TUB

- There can be a water leakage from the tub

ELECTRONIC CARD

- Electronic card can be out of order.

F2 (THE WASTE WATER IN THE MACHINE CANNOT BE DISCHARGED)

Drain hose

- Water outlet hose is clogged
- Check of the water outlet hose position.

Drain pump

- Check the drain pump resistance and power values
- There can be a problem with cable connection of the drain

Pressure switch

- Pressure switch of the heater casing group can have a mechanical or cable connection problem.

F3 (ERROR OF CONTINUOUS WATER INPUT)

Water inlet valve

- Water inlet valve can be out of order or can not be closed.

Electronic card

- Electronic card can be out of order.

F4 (FLOWMETER FAULTY)

Flowmeter

- Flowmeter can be out of order.
- Cable connection of flowmeter can be faulty.

Electronic card

- Electronic card can be out of order.

F5 (INADEQUATE WATER SUPPLY)

Water tap

- Make sure the water input tap is totally open and that there is no water cut.

Water inlet hose

- Close the water input tap, separate the water input hose from the tap and clean the filter at the connection end of the hose.

Water inlet valve

- Water inlet valve filter can be clogged.
- Water inlet valve can be out of order. There can be a problem with the cable connection of water inlet valve.

Floater

- Floater switch can be out of order or have a problem with the cable connection.

Pressure switch

- Pressure switch of the heater can have a mechanical or cable connection problem.

Circulation pump

- Circulation pump can be out of order or have a problem with the cable connection. External part can be blocked to the circulation pump.

F6 (NTC FAULTY)

Ntc

- Ntc can be out of order.
- Ntc cable connection can be faulty. Ntc can be short or open circuit.

Electronic card

- Check the power and resistance value of heater.
- Check the cable connection of the heater.

F7 (EXTREME HEATING UP FAULTY)

Ntc

- If the water temperature inside machine higher than 77°C, ntc can be out of order.

Electronic card

- Electronic card can be out of order.

F8 (INADEQUATE HEAT)

Heater

- Check the power and resistance values.
- Check the cable connection of the heater.

Electronic card

- Check the electronic card

F9 (DIVERTER POSITION PROBLEM)

Diverter

- Check the values of the diverter.
- Check the cable connection of the diverter.

Electronic card

- Check the electronic card

FA (TURBIDITY SENSOR FAULTY)

Turbidity sensor

- There can be some soil around the turbidity sensor.
- Check the cable connection of the turbidity sensor.

Electronic card

- Check the electronic card.

BLDC MOTOR CONTROL TEST

Press “Select” button. Switch-on the dishwasher. Keep pressing “Select” button for 3”.

For A4 models,press upper basket touch buttoni turn on machine and continue to press upper basket button for 3”.

Increase level by pressing upper basket touch button

Decrease level by pressing lower basket touch button.

After 3”, display shows “Pco” (means that Pump control) characters during 2 sec, then “200” characters appear and BLDC motor start performing with 2000 rpm.

Rpm values can be raised or decreased one by one.

Press “Options” button to raise RPM values from 2000 to 3400.(200,210,220,...,340)

Press “Select“ button to decrease RPM values by hundred from 3400 to 2000.(340,330,320,...,200)

-Test can be finished by pressing On/Off button.

6.17 VOICE CONTROL TEST (for models having Auto Door mechanism)

First energize the machine via main switch (if it is in OFF position).

Press option and select buttons for 3”.

If voice controlling is done first time, at the end of 3 seconds, “S:03” is shown in the display and Buzzer gives a long sound. (level of 3) (Factory setting is set to ”S:03”)

User can open or close the voice level with “Program” and “S/P“buttons. The characters must be as follow;

By each pressing “Select “button,

- Display screen changes S:03 to S:00
- Level of sound is decreased
- ”S:00” level that means all voices are off

By each pressing “Option” button

- Display screen changes from S:00 to S:03
- Level of sound is increased

Machine’s power must be off to exit voice control mode

The last voice level that user determined before must be stored in memory.

For A4 series use Lower basket solundaki ikon +lower basket buttons and press them for 3” to change sound level.

AUTOMATIC PROGRAM(TURBIDITY SENSOR)

Turbidity sensor is performed in the “auto delicate”, “auto normal” and “auto intensive” programs

- 1) The calibration is executed after reaching P1 level in the first filling step.
- 2) The first measure is executed at the end of pre-wash.
 - If turbidity is \leq TURBIDITY-LEVEL 1: drain is skipped.
 - If turbidity is $>$ TURBIDITY-LEVEL 1: drain is skipped.
- 3) The second measure is executed at the end of hot pre-wash.
 - If turbidity is \leq TURBIDITY-LEVEL 2: Drain is skipped.
 - If turbidity is $>$ TURBIDITY-LEVEL 2: Drain is skipped.
- 3) The third measure is executed after the first heating step in the main wash.
 - If turbidity is \leq TURBIDITY-LEVEL 3: The second heating step is skipped
 - If turbidity is $>$ TURBIDITY-LEVEL 3: The second heating step is performed (T24_7 is performed)
- 4) The fourth measure is executed at the beginning of rinses.
 - If turbidity is \leq TURBIDITY-LEVEL 4: First rinse is skipped.
 - If turbidity is $>$ TURBIDITY-LEVEL 4: First rinse is executed.

The levels :

TURBIDITY-LEVEL 1 = 3,0V

TURBIDITY-LEVEL 2 = 3,4V

TURBIDITY-LEVEL 3 = 3,7V

TURBIDITY-LEVEL 4 = 3,8V

In case of break of turbidity sensor, the Automatic cycle is entirely executed. The fault is not reported.

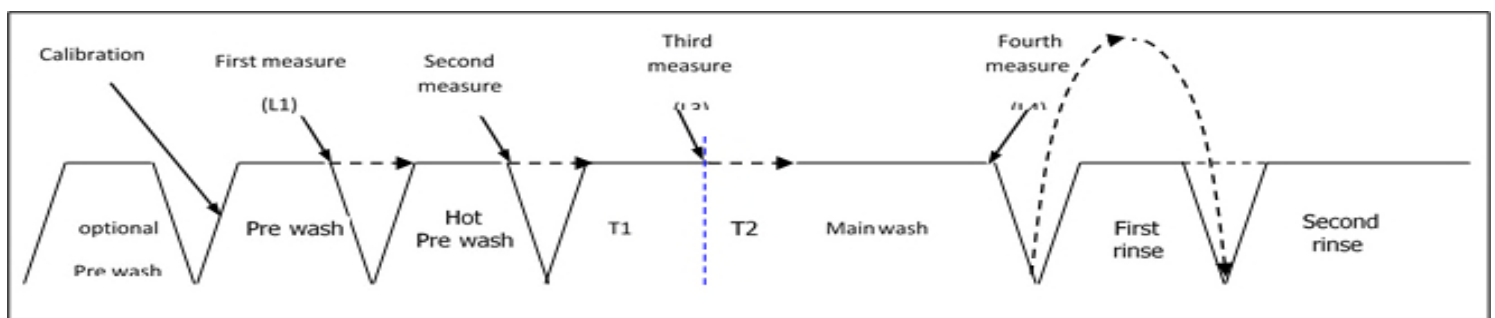

NECESSARY INFORMATION HAVE TO BE GIVEN TO USERS WHILE INSTALLATING THE DISHWASHER

Customer should be informed about following items.

- Give general information to user about the product.
- General information about washing programmes and suggest to the customer using suitable program according to the dirtiness level.
- Give information about additional functions.
- Give information to the customer about starting the machine, following the program, resetting the program and changing the program.
- Give information about activate and inactive the child lock. Customers should be informed about the child lock will not be inactive automatically at the end of the programme.

Models haved $\frac{1}{2}$ half load option;



In $\frac{1}{2}$ option when only upper Lamp is flashed, only upper spray Will be in operation.



In $\frac{1}{2}$ option, when only lower lamp is flashed, only lower spray will be On operation.



When both lamps are flashed, this Function is half load function. If the Customers have little amount of Dishes, they should use this function.

When both lamps are not flashed, It means the machine will continue normal operation. When the lamps are not flashing, does not mean spray arms are not rotating.

- The customers should be informed about looking at instruction manual at first, when they face to failure.
- After installing the machine to a suitable place, run it unloaded for the first time.

This should be recommended to the customers that they should search the instruction manual carefully when there is a possible repair.

REPAIR TECHNIQUES COMPONENTS AND RESISTANCE VALUES

COMPONENTS	C		T		NOTES
ON / OFF SWITCH	0 Ω on component		0 Ω on component		ON/OFF button is pressed
DOOR SWITCH	CN2.9 - CN2.2 0 Ω		KN2.8 - KN2.10 0 Ω		Door is close
PRESSURE SWITCH	CN2.10 - CN2.2	0 Ω ∞ Ω	KN2.9 - KN2.10	0 Ω ∞ Ω	Full fill water no water
DRAIN PUMP / HANYU	CN2.2 - CN2.4	220 Ω % ±10	KN2.4 - KN2.10	220 Ω % ±10	
DRAIN PUMP / LEIJI	CN2.2 - CN2.4	141 Ω % ±10	KN2.4 - KN2.10	141 Ω % ±10	
WATER INLET VALVE	CN2.6 - CN2.9	4200 Ω ± %10 (20°C)	KN2.6 - KN2.8	4200 Ω ± %10 (20°C)	
REGENERATION VALVE	CN2.2 - CN2.7	3560 Ω ± %10(25°C)	KN2.2 - KN2.10	3560 Ω ± %10(25°C)	
SALT SENSOR	CN5.1 - CN5.2	0 Ω NO SALT ∞ Ω THERE IS	KN50.10 - KN 50.11	0 Ω NO SALT ∞ Ω THERE IS SALT	Measure just on the electronic
HEATER	29.1 ± 1.5 Ω		29.1 ± 1.5 Ω		Measure just on the component
DETERGENT DISPENSER	2300 Ω ±%10 (25 C°)		2300 Ω ±%10 (25 C°)		Measure just on the component
CIRCULATION PUMP	CN2.3 - CN2.9		KN2.3 - KN 2.8		Primary winding Secondary winding (from the component)
SET NTC SENSOR	CN 3.2 CN 3.1		KN 50.1 KN 50.2		
FAN MOTOR	CN 6.2 - CN 2.9		KN 6.2 - KN 2.8		
DIVERTER	CN 6.1 - CN 2.9 10500 ± %7 Ω		KN 6.1 - KN 2.8 10500 ± %7 Ω		
RINSE AID SENSOR	CN 5.3 - CN 5.2	0 Ω NO RINSE AID ∞ Ω THERE IS RINSE	KN 50.8 - KN 50.9	0 Ω NO RINSE AID ∞ Ω THERE IS RINSE AID	Rinse aid off Rinse aid on
FLOATER (MICROSWITCH)	CN2.1 - CN 2.5 CN2.1 - CN 2.4	0 Ω ∞ Ω	KN2.5 - KN 2.10 KN2.4 - KN 2.5	0 Ω ∞ Ω	Microswitch is inactive (no water) microswitch is active (there is water)

MEASURING THE COMPONENTS FROM THE ELECTRICAL CARD

You might measure the components either connectors of electronic card or directly on the component.

Measuring from the connectors of electronic card gives definite result to define the repair. If you know the specialities and values of tester, you can easily determine the repair.



Picture (a)

Example electronic card

Probes of the tester should be applied on to the related connectors of the electrical card; control the values according to the resistance value table. Picture (a)

COMPONENT VALUES MEASUREMENT

Precaution: Always remove the plug from the power socket before touching internal components.

WASHING PUMP:

From the electrical card:

You can only measure the primary winding value from the electrical card. Resistance value of the primary winding must be

	C	T	
CIRCULATION PUMP	CN2.3 - CN2.9	KN2.3 - KN 2.8	Primary winding Secondary winding (from the component)

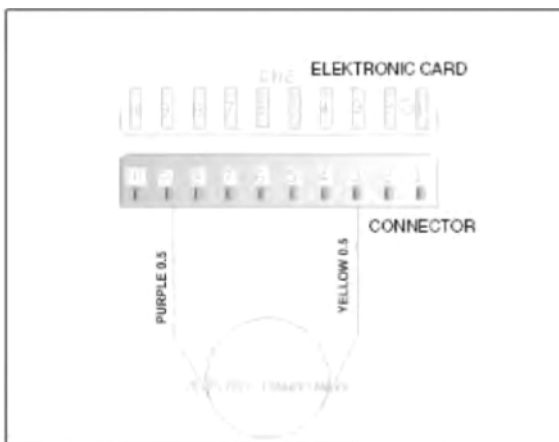

Above sketch show the connectors of the washing pump on the electrical card. Probes of the tester should be applied on to the related connectors.

From the component:



Measurement of the primary windings of the washing pump. (118.2-135.9 Ω)



Measurement of the secondary windings of the washing pump (white cable – blue cable) (117.9-135.6 Ω)

Probes of the tester should be applied on to the related connectors as shown on the pictures.

DRAIN PUMP

From the electrical Card:

	C	T
DRAIN PUMP / HANYU	CN2.2 - CN2.4 $220 \Omega \pm 10$	KN2.4 - KN2.
DRAIN PUMP / LEILI	CN2.2 - CN2.4 $141 \Omega \pm 10$	KN2.4 - KN2.

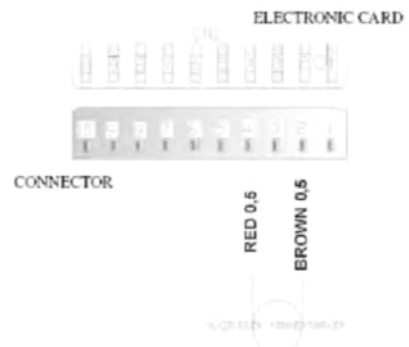

Above sketch show the connectors of the drain pump on the electrical card. Probes of the tester should be applied on to the related connectors.

From the component:



Probes of the tester should be applied on the related connectors as shown on the pictures.

WATER INLET VALVE

From the electrical Card:

	C	T
WATER INLET VALVE	CN2.6 - CN2.9 4200 Ω ± %10 (20°C)	KN2.6 - KN2.8 4200 Ω ± %10 (20°C)

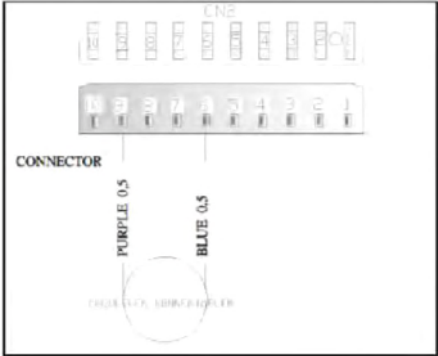

Above sketch show the connectors of the water inlet valve on the electrical card. Probes of the tester should be applied on to the related connectors.

From the component:



Probes of the tester should be applied on to the related connectors as shown on the pictures.

HEATER

It can't be measured from the electrical card.

From the component:

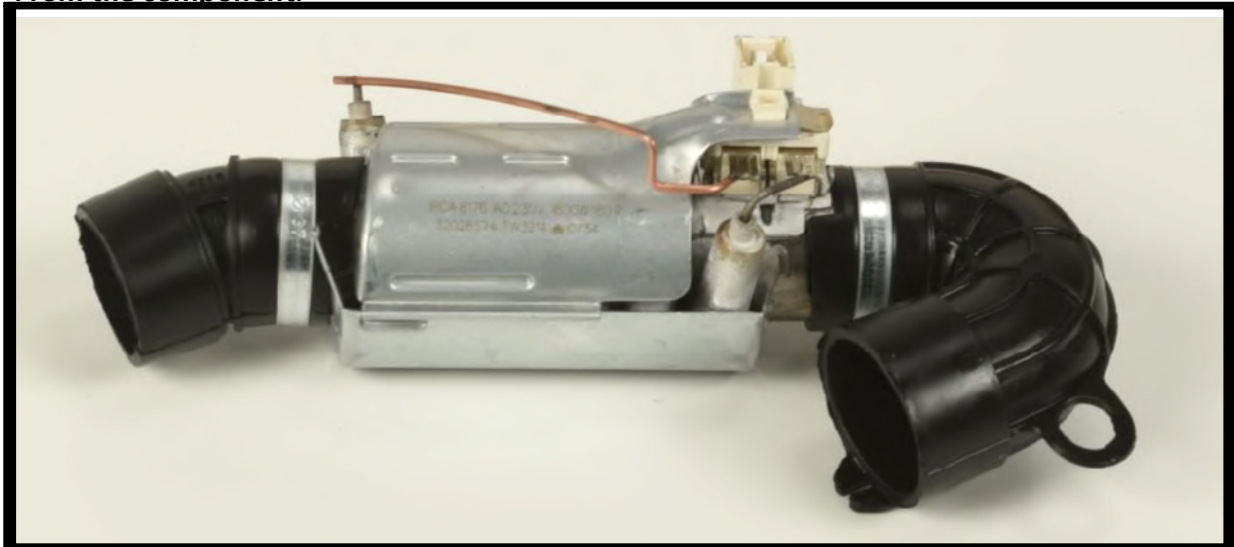

DETERGENT DISPENSER

It can't be measured from the electrical card:

	C	T
DETERGENT DISPENSER	2300 Ω \pm 10% (25 C°)	2300 Ω \pm 10% (25 C°)

From the component:

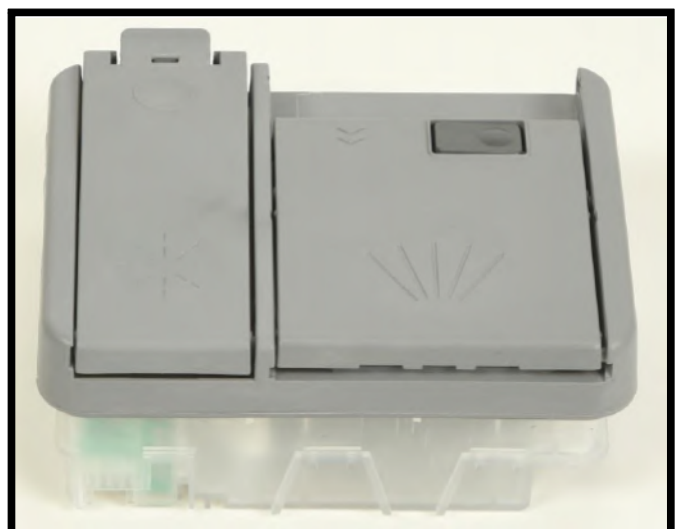

REGENERATION VALVE

From the electrical Card:

	C	T
REGENERATION VALVE	CN2.2 - CN2.7 3560 Ω ± %10(25°C)	KN2.2 - KN2.10 3560 Ω ± %10(25°C)

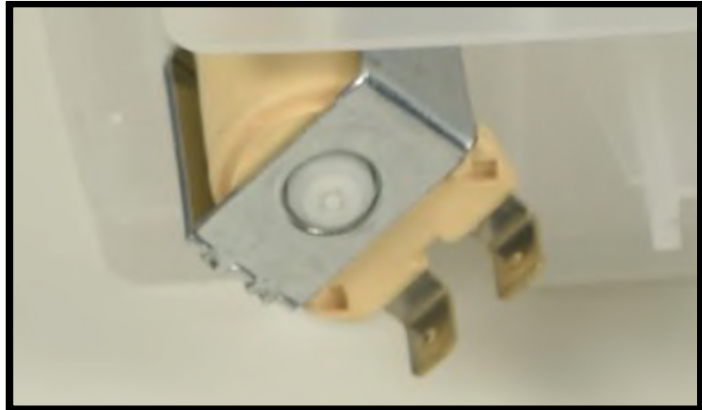
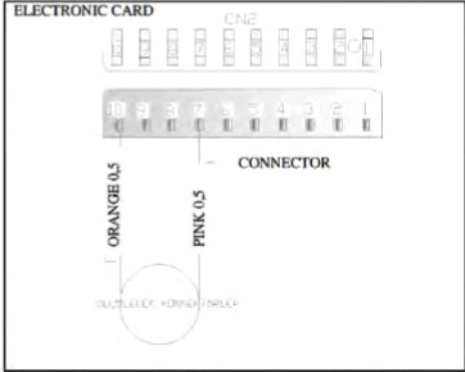
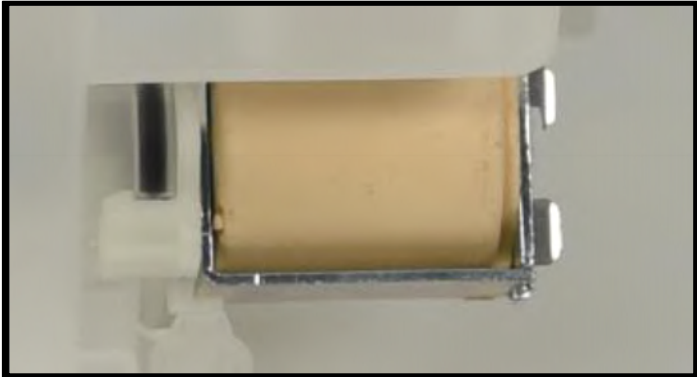

Above sketch show the connectors of the regeneration valve on the electronic card. Probes of the tester should be applied on to the related connectors.

From the component:



PRESSURE SWITCH

From the electrical card:

		C		T	
PRESSURE SWITCH	CN2.10 - CN2.2	0 Ω ∞Ω		KN2.9 - KN2.10	0 Ω ∞Ω Full fill water no water

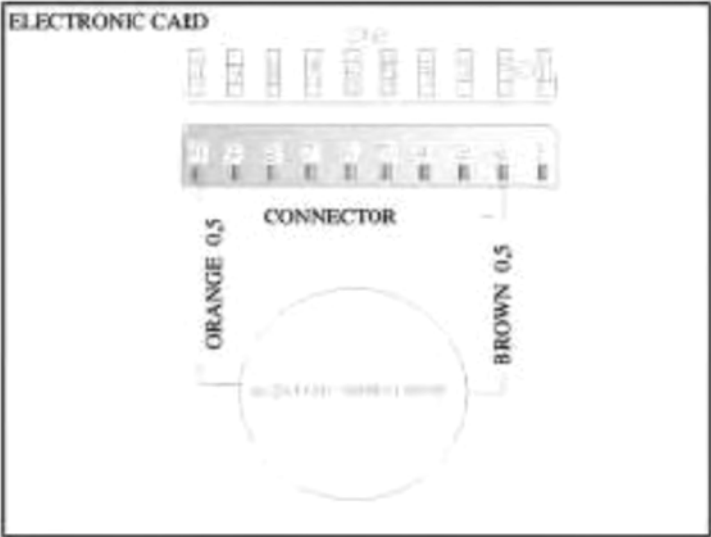

From the component:

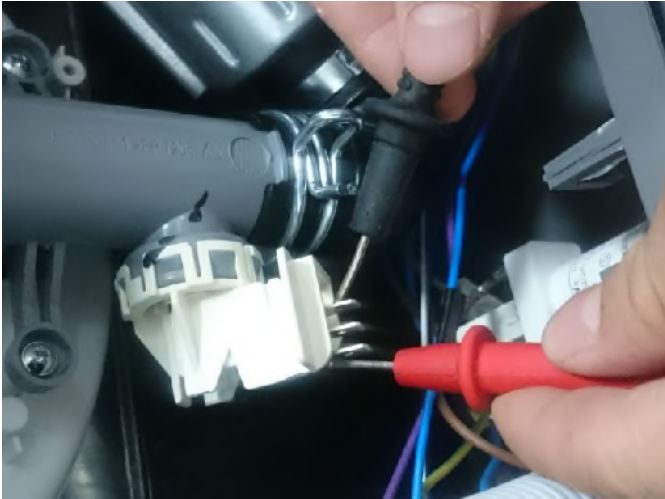

Probes of the tester should be applied on to the related connectors as shown in the picture above.

DIVERTER

From the electrical Card:

	C	T
DIVERTER	CN 6.1 - CN 2.9 10500 ± %7 Ω	KN 6.1 - KN 2.8 10500 ± %7 Ω

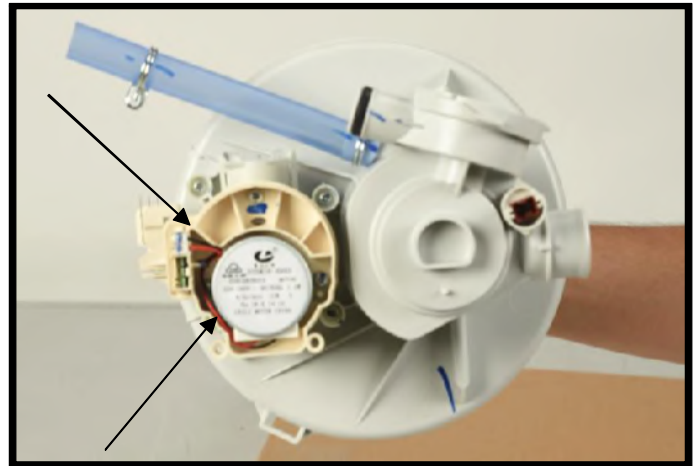
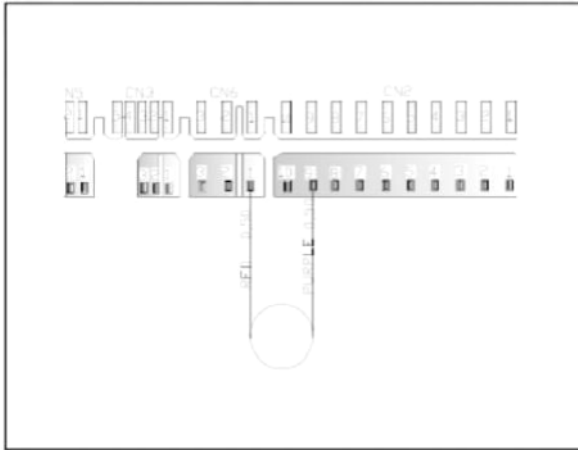

Sketch above show the connectors of the diverter on the electrical card. Probes of the tester should be applied on to the related connectors.

From the component:



Probes of the tester should be applied on to the related connectors as shown on the pictures.

SALT SENSOR

From the electrical card:

		C		T	
SALT SENSOR	CN5.1 - CN5.2	0 Ω NO SALT ∞Ω THERE IS SALT	KN50.10 - KN 50.11	0 Ω NO SALT ∞Ω THERE IS SALT	Measure just on the electronic

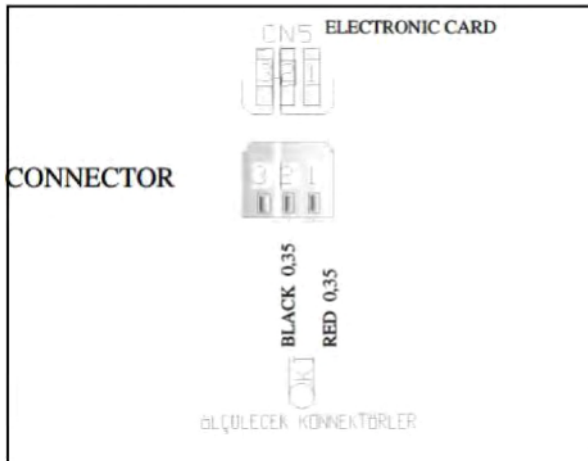

Sketch above show the connectors of the salt sensor on the electrical card. Probes of the tester should be applied on the related connectors.

From the component:

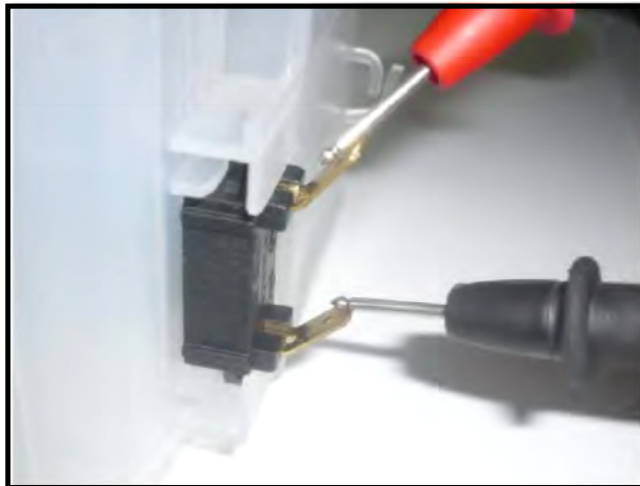

salt sensor can also be measured from the water softener when the salt sensor is assembled on the water softener.

Probes of the tester should be applied on to the related connectors as shown on the pictures.

FLOATER

From the electrical card:

		C		T	
FLOATER (MICROSWITCH)	CN2.1 - CN 2.5 CN2.1 - CN 2.4	0Ω $\infty\Omega$		KN2.5 - KN 2.10 KN2.4 - KN 2.5	0Ω $\infty\Omega$ Microswitch is inactive (no water) microswitch is active (there is water)

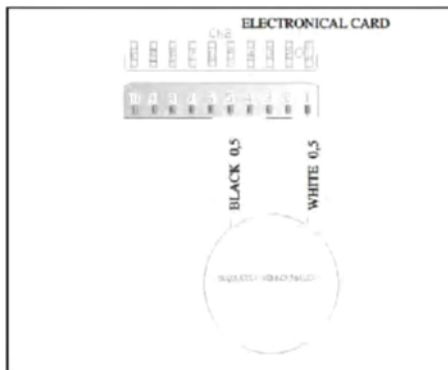
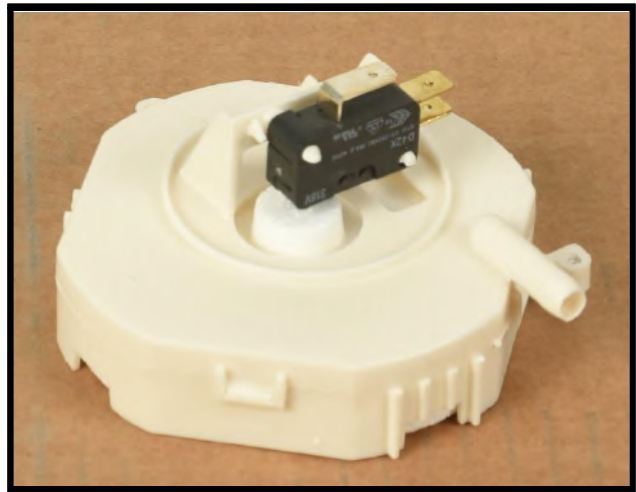
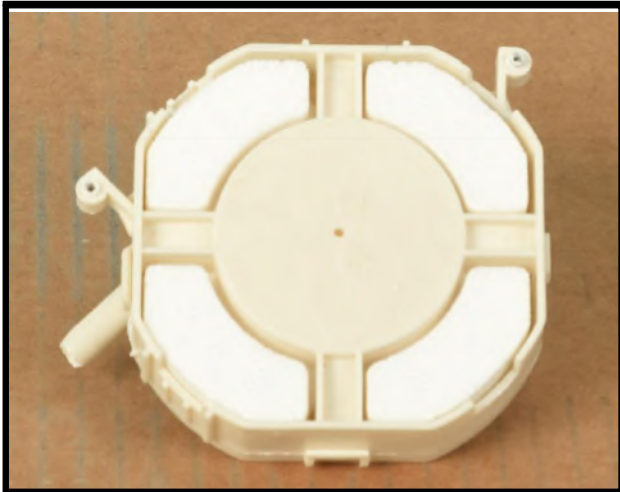

Position 1 : You can check the floater by controlling the specified value intervals.

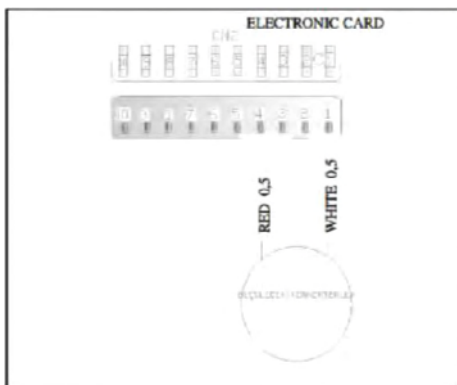

Position 2 : If failure code is occurred related with the floater within control the above values: You can figure out whether leakage occurs or not.

DOOR SWITCH

From the electrical card:

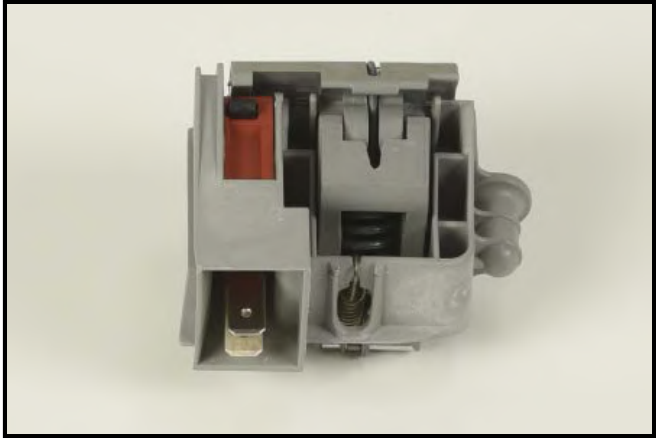
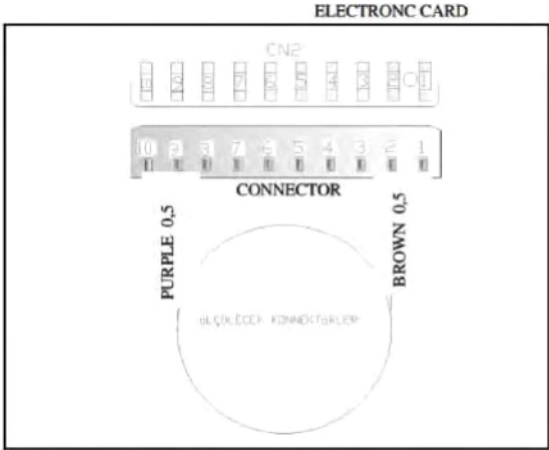

Above sketch show the connectors of the door switch on the electrical card.

From the component:

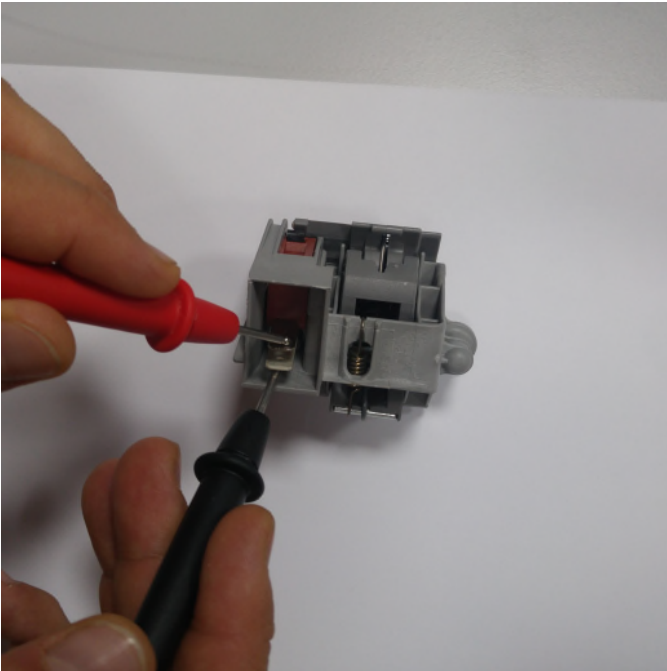

Probes of the tester should be applied on to the related connectors as shown on the pictures.

FAN MOTOR

From the electrical card:

	C	T
FAN MOTOR	CN 6.2 - CN 2.9	KN 6.2 - KN 2.8

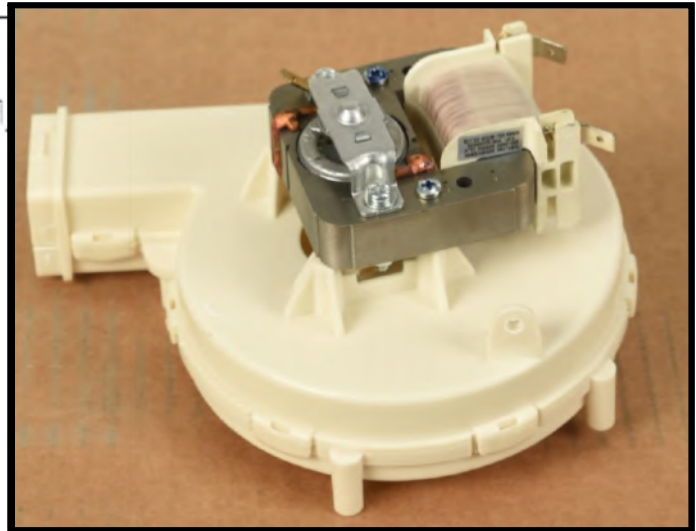
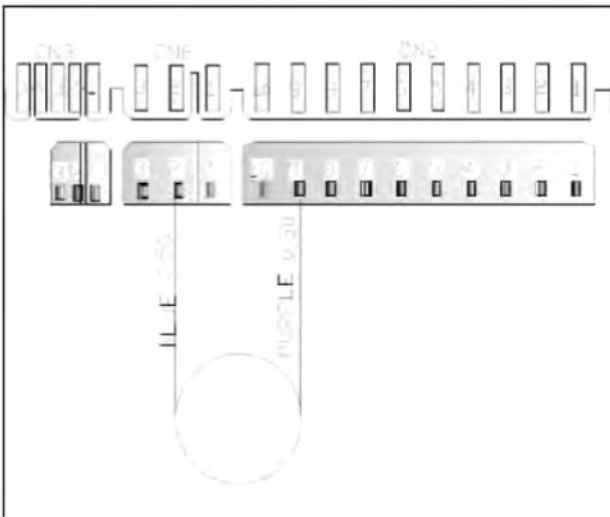

Above sketch shows the connectors of the fan motor on the electrical card.

From the component:



Turbo fan resistance value: $265 \pm 10\% \Omega$ (The resistance of the turbo fan is measured with the resistor switch).

RINSE AID SENSOR

From the electrical card:

		C		T	
RINSE AID SENSOR	CN 5.3 - CN 5.2	0 Ω NO RINSE AID ∞ Ω THERE IS RINSE AID	KN 50.8 - KN 50.9	0 Ω NO RINSE AID ∞ Ω THERE IS RINSE AID	Rinse aid off Rinse aid on

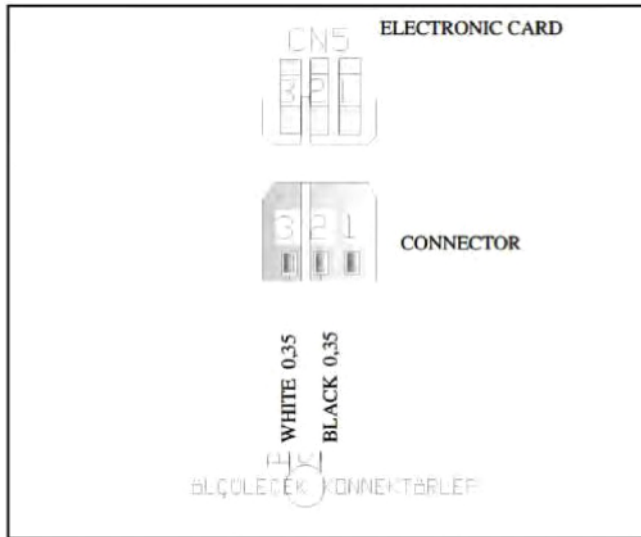

Above sketch shows the connectors of the rinse aid sensor on the electrical card.

From the component:

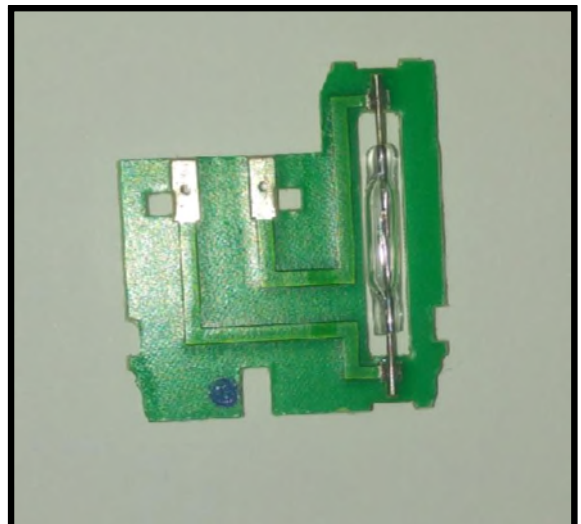
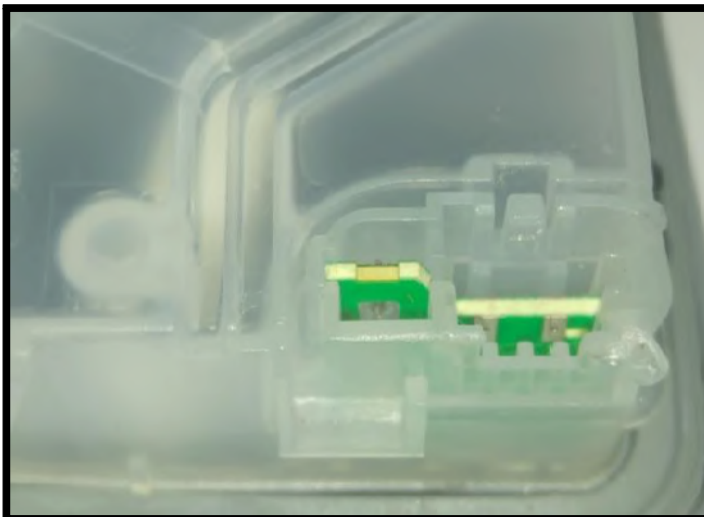

Probes of the tester should be applied on to the related connectors as shown on the pictures.

Poor drying

- a) The programme which hasn't got a drying phase; could be selected the customers should be informed about the programmes.
- b) there might be lack of rinse aid compartment.

FYAA23, FNAA15 have rinse aid indicator on the control panel.

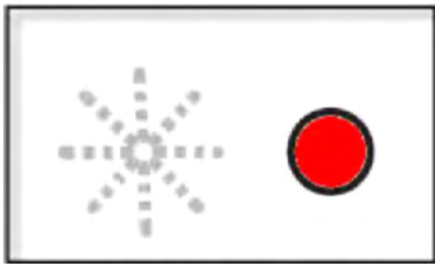

There isn't any rinse aid



there is rinse aid

- c) There can be mechanical or electrical problem with the detergent dispenser.
- d) There can be a problem on the PCB card.