



SECHE LINGE

SERVICE MANUEL

BANDEAU F2



4. CONTROL PANEL AND PROGRAM SELECTION TABLE

4.1. Control Panel

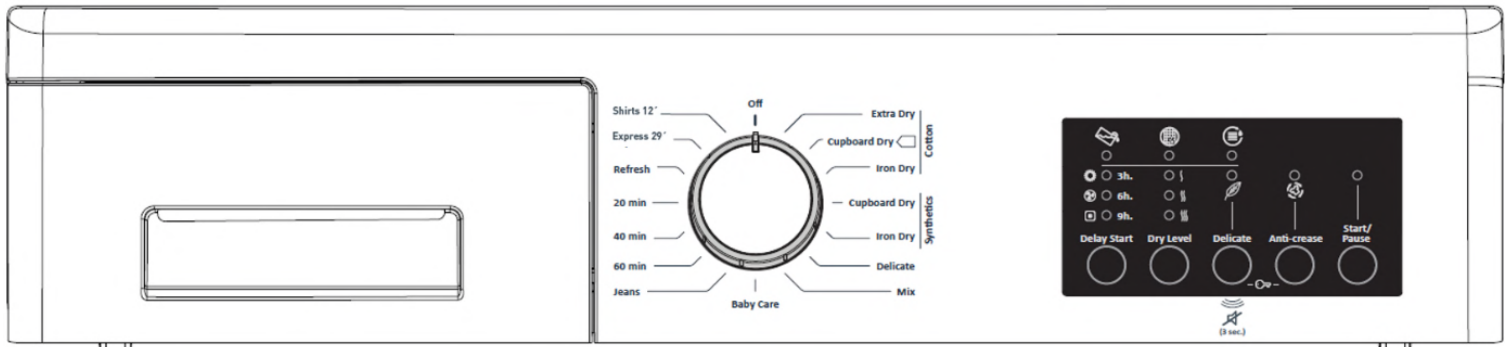

Display Symbols

Water tank warning indicator	
Lint filter cleaning warning indicator	
Condenser cleaning warning indicator	

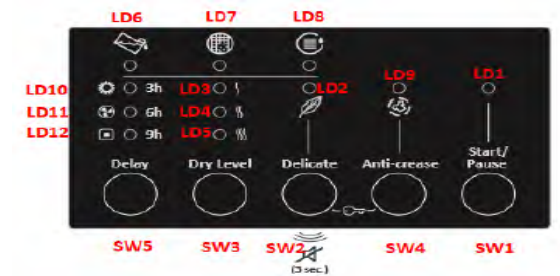

4.2. Program List

KNOB POSITION	PROGRAM
1	Cotton Extra Dry
2	Cotton Cupboard Dry
3	Cotton Iron Dry
4	Synthetics Cupboard Dry
5	Synthetics Iron Dry
6	Delicate
7	Mix
8	Baby Care
9	Jeans
10	60 min
11	30 min
12	10 min
13	Refresh
14	Express 29'
15	Shirts 12'
16	OFF

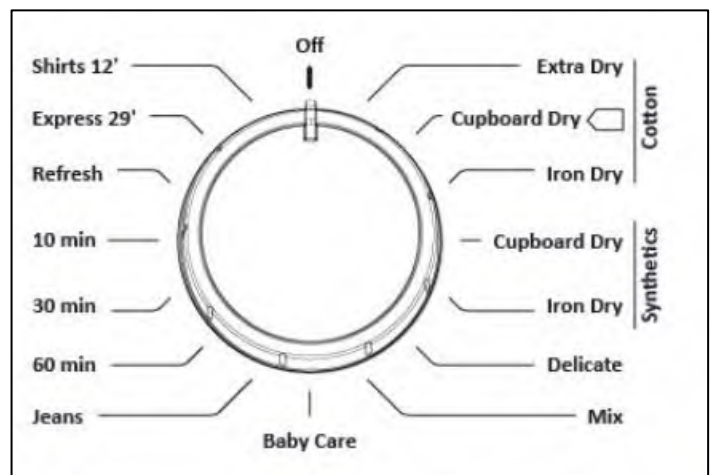

***The machine has humidity sensor that detects whether the laundry dry or not. At the programs that work with humidity sensor laundry does not dry in fixed time. Duration is constantly updates according to humidity data taking from laundry

*****Time Drying Program: 60min /30min / 10min** Humidity sensor is deactivated. The program ends when the time is up, without checking the humidity of the laundry.

*****Express 29' / Shirts 12 ':** Humidity sensor is activated. The program time may extend, if the customer use different laundry according to the load in the program description.

Express 29' : 2 kg of cotton shirts spun at a high speed in the washing machine are dried in 29 minutes.

Shirts 12' : 2 to 3 shirts are ready for to be ironed in 12 minutes.

*****Delicate:** Delicate fabrics are dried for a longer time at a low temperature.

4.3. Children's Safety

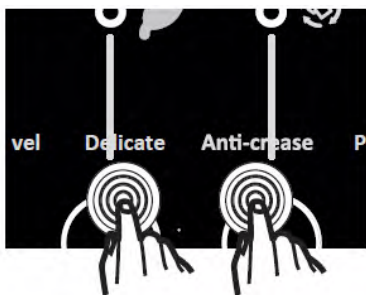

There is a child lock option to avoid changes in the program flow when keys are pressed during the program.

There is a child lock option to avoid changes in the programme flow when keys are pressed during the programme. To activate the child lock, press and hold the "Anti-Crease" and "Delicate Drying" keys simultaneously for 3 seconds. When the child lock is active, all keys

will be deactivated. Child lock will be deactivated automatically at the end of the programme.

When activating/deactivating the child lock, the LEDs of the "Anti-Crease" and "Delicate Drying" options will flash and an audible warning will be heard.

5.FAILURE MODES AND SERVICE AUTOTEST

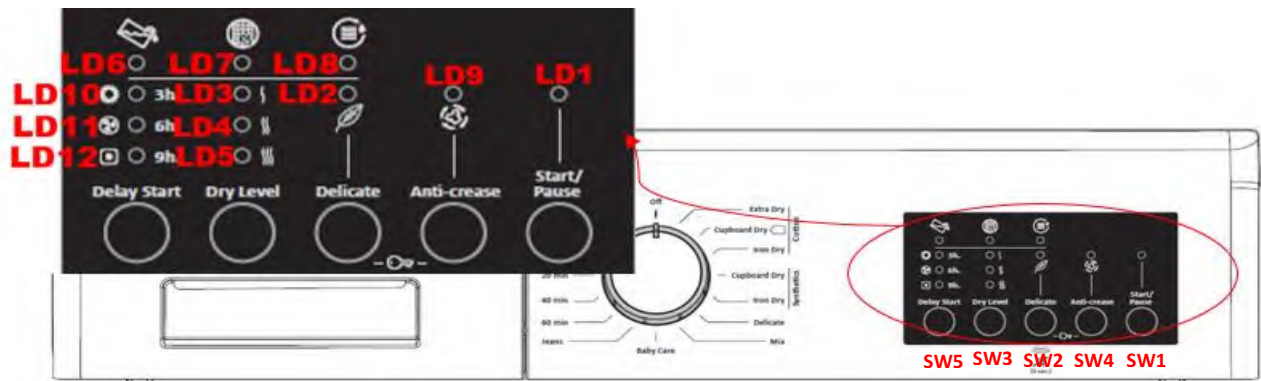

*****Service auto test must be run for every service call.**



The case in the photo don't show us a failure code. Normally, when the drying program ends, the filter, water tank and end led are flashing. In addition, condenser cleaning warning led is on every 30 cycles.

5.1.Failure Modes and Warning Leds

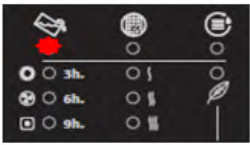
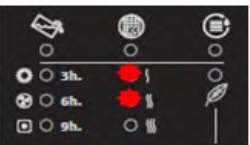
The filter and condenser cleaning warning leds are flashing	The filter might be clogged by lint	Clean the lint filter.
	There might be a layer that causes obstruction on the surface of the lint filter.	Wash the lint filter with lukewarm water.
	The condenser might be clogged by lint	Wash and clean the condenser.

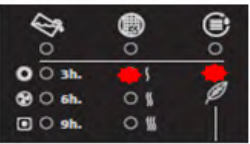
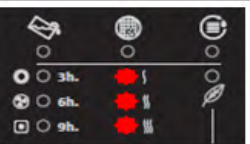
F2 CONDENSER MODEL ERROR CODES	
ERROR CODE	REASON
E03 	Aquaswitch connector is disconnected
E04 	Heater connector is disconnected
E05 	Heater NTC connector is disconnected
E06 	Door NTC connector is disconnected
E08 	Voltage fluctuation

Notes For Service autotest:

*Service can not pass the current step before completing the minimum duration

*When minimum duration for each step (5 sec) is completed, filter led makes **slow blink** to indicate that service can pass the next step

*For error codes, leds must make **fast blink**

*****Power analyzer must be plugged and machine is connected to this analyzer.**

5.2 Service Auto Test Steps

Steps	Control	Led	Possible Errors
Enter Servis Autotest	<p>While pushing SW2 button for 5 sec, position knob to Program 1. Then press Start/Pause button. Machine enters to service autotest. All warning leds makes fast blink for 2 sec and then becomes fix off</p> <p>Machine will show the last error.</p> <p>When knob positioned to program 2, control steps starts.</p>		
Step 2 (Knob Position 2)	Software check Aqua switch	LD6	Aqua switch connector is taken out Aqua switch connector is short circuit Styrofoam is broken or not
Step 3 (Knob Position 3)	Pump activation is checked by service person	-	Service must pour water to pump reservoir and check whether water is pumped to tank. If water is not pumped to water tank; Pump connector is taken out
Step 4 (Knob Position 4)	Motor motion is checked by service person Motor CCW (Drum CW)-Motor stops	-	Service must check whether drum is moving to CW. If not; Motor connector is taken out Motor might be locked Motor belt might be dislocated
Step 5 (Knob Position 5)	Motor motion is checked by service person Motor CW (Drum CCW) -Motor stops	-	Service must check whether drum is moving to CCW If tumble is moving to CW again, then motor relay short circuit CCW
Step 6 (Knob Position 6)	Software checks heater NTC	LD3- LD5	Heater NTC connector is taken out or short circuit
Step 7 (Knob Position 7)	Software checks door NTC	LD2 - LD3	Door NTC connector is taken out or short circuit
Step 8 (Knob Position 9)	Heater power is checked by using energy analyzer by service Resistance (1600W+900 W)- Motor CCW (Drum CW) -motor off	-	Power of heater must be checked according to voltage of home***
Step 8 (Knob Position 9)	Service person check conductivity sensor when door is opened and motor is off by putting his hands on the conductivity sensor	LD2 - LD5	Service puts his hand on the humidity sensor plates and software checks sensor data If sensor data=0, humidity sensor connector may not be properly assembled. Check the assembly.

7. COMPONENT SPECIFICATIONS AND MEASUREMENTS

7.1. Motor

The dryer has an asynchronous motor. In the photo on the right, the socket on the motor are shown to be measured by multiple counters. It is driven with triac via the electronic card (to give energy) and relay (for direction control).

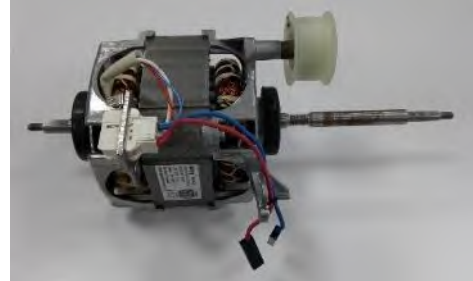

Technical Features

Type: single-phase asynchronous motor
 Power: 200 W (Unloaded drum)
 Main windings: 21.5±7% (20 °C temp.)
 Aux windings: 19.5±7% (20 °C temp.)

Motor speed : 2750 rpm (Unloaded drum)
 Drum speed : 52 ± 2
 Capacitor value : 11 µF ± %5

Component Test

- Check whether the motor cable is connected to the motor connector.
- Check the connection of the capacitor cables
- Measure the resistance values and check the capacitor values
- Check whether it is working by connecting via the terminals 1 and 2 (Blue-White) connection
- If it is working, revolution of the drum is measured in unloaded state.

The terminals 1-3 of the motor should be connected with capacitor

Resistance measurement of main winding: Terminal 1 -2 (Blue-White) is measured.

Resistance measurement of aux winding: Terminal 3 -2 (Red-White) is measured.

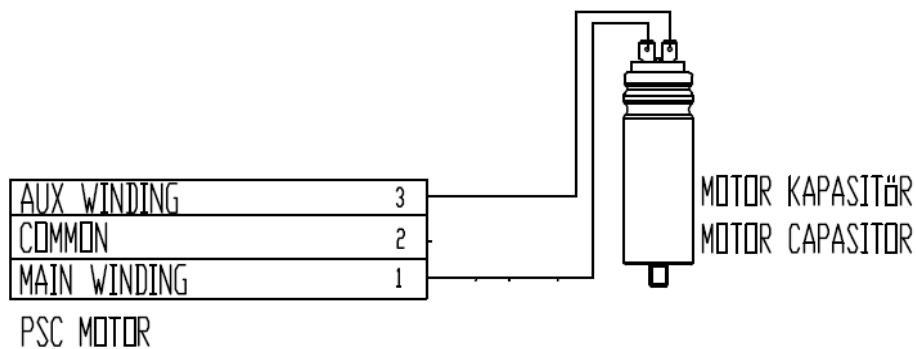

7.1.1. Motor Measurements



7.2. Pump

In Tumble Dryer models, the pump is used to transport the water that accumulates in the condensation chamber to tank in the drawer area. One triac is measured on the electronic card.



Technical Features

Resistance : 764±10% ohm
Voltage: 220-240 Volt
Frequency: 50 Hz

Input Power : 13W max

Component Test

- Check the connection of the pump connector
- Check the pump resistances
- Check whether pump is working, by feeding externally
- If the pump is working, the water in the tank is unloaded by running the pump Then, Unload 500 ml of water from water tank to pump reservoir and check whether water is pumping.
- While pump is working, if water is not reached into water tank, hoses should be checked.

7.2.1 Pump Measurements

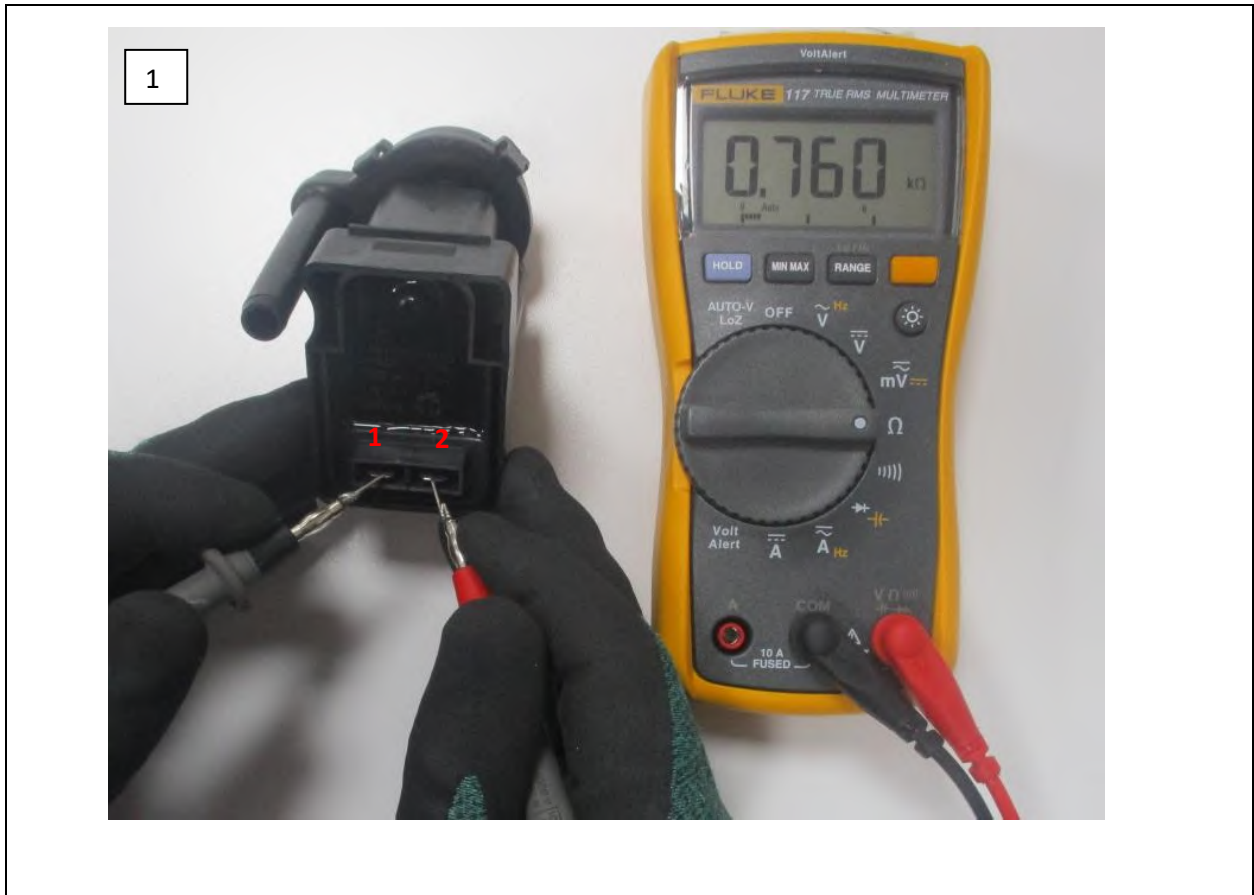

7.3. Electronic Card

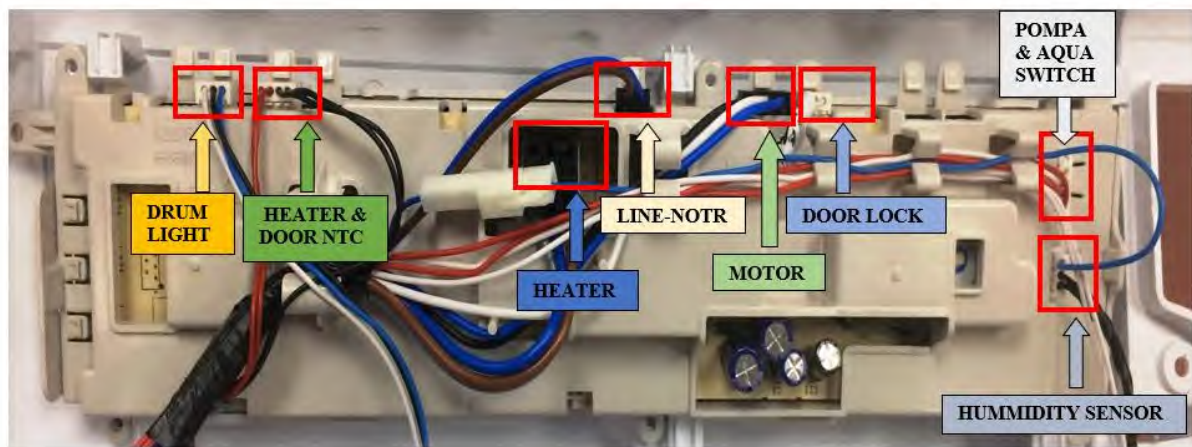
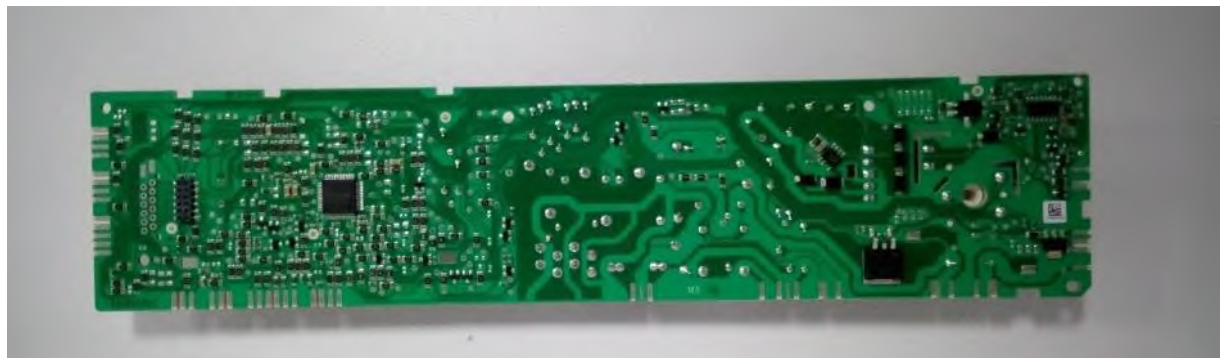

Technical Features

Electronic card is single sided printed circuit board and CEM-1 material

The upper picture shows where the components are inserted.

7.4. Door/Heater NTC Sensor

Two NTC sensors are used. The NTC resistance decreases when the temperature rises. The heater works till the temperature reach required value.



Technical Features

Door NTC Resistance : 12 kΩ (Measured from IDC connected to electronic card) (20 °C temp.)

Heater NTC Resistance : 19.5 kΩ (Measured from IDC connected to electronic card) (20 °C temp.)

Component Test

- Resistance is measured from IDC connected to electronic card
- If the resistance cannot be measured, (from door, 7-pin sockets or heater) check the connector connections of the NTCs
- If there is no problem about connector , check whether there is break in the cables by using multimeter



7.4.1. Door NTC Sensor Measurements

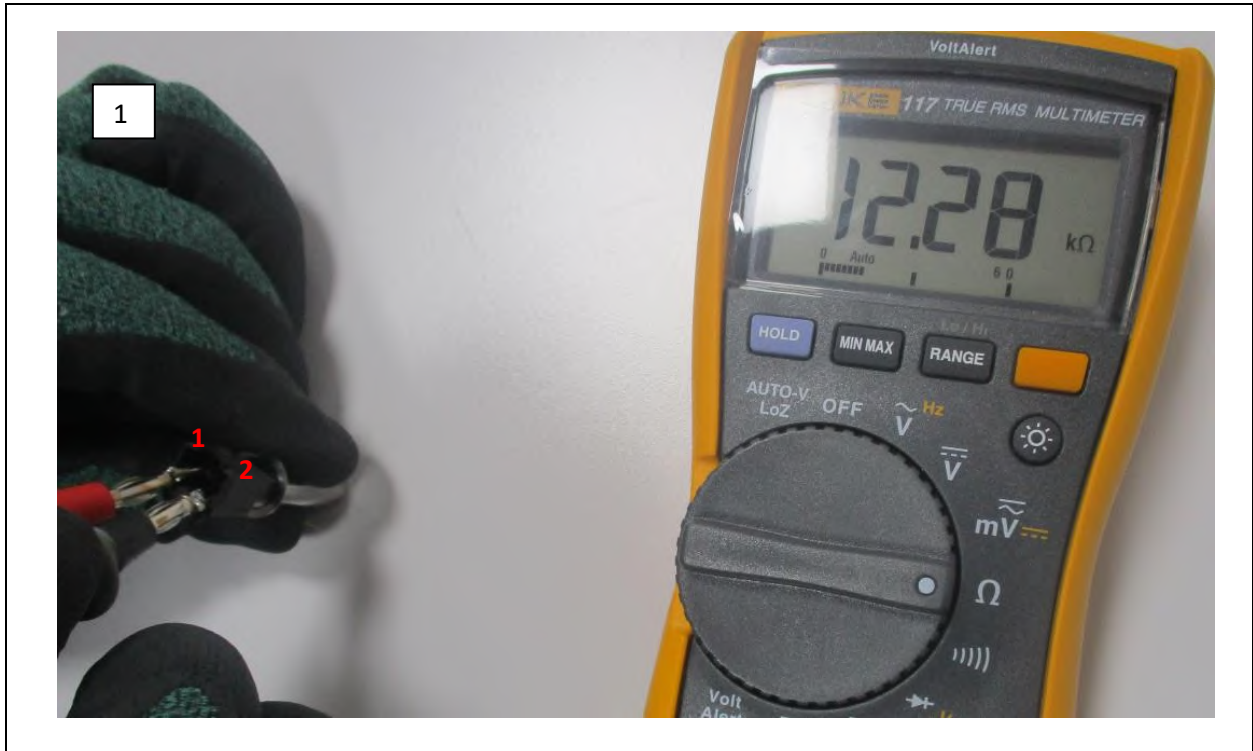

7.4.2. Heater NTC Sensor Measurements



7.5. Heater

Resistance is the component used to increase the temperature of the air in the drum. It consists of two stages (1600+900=2500W). It is controlled by two relays via electronic card.

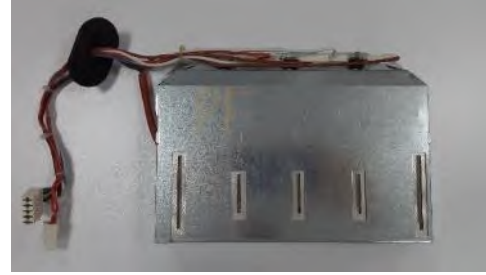

Technical Features

Type : Open spiral heater

Nominal Power and Voltage: 230VAC, 1600+900 W = 2500 W ± %5

Resistance : 1600 W stage 1 (33.44 Ω ± %5) – measured from terminal 3 and 6
: 900 W stage 2 (59.45 Ω ± %5) – measured from terminal 3 and 7

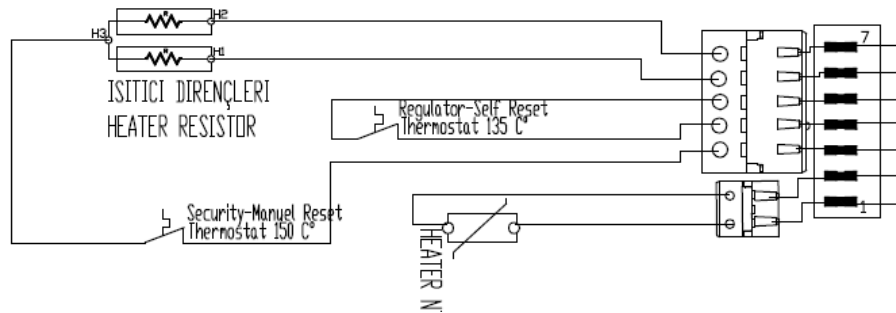

Component Test

- Heater resistances are measured from sockets
- If resistance cannot be measured, check the connection of the heater connectors with 7-pin sockets. Heater connectors must be plugged into 7-pin connectors in accordance with their password. Connections of the manual thermostat and auto thermostat connector on the heater are checked. The thermostat with manual reset is checked whether there is open circuit at the terminals by the multimeter. If it's open circuit, button is up and the heater doesn't work. By pressing the button circuit will be closed, then heater works.



7.5.1. Heater Measurements

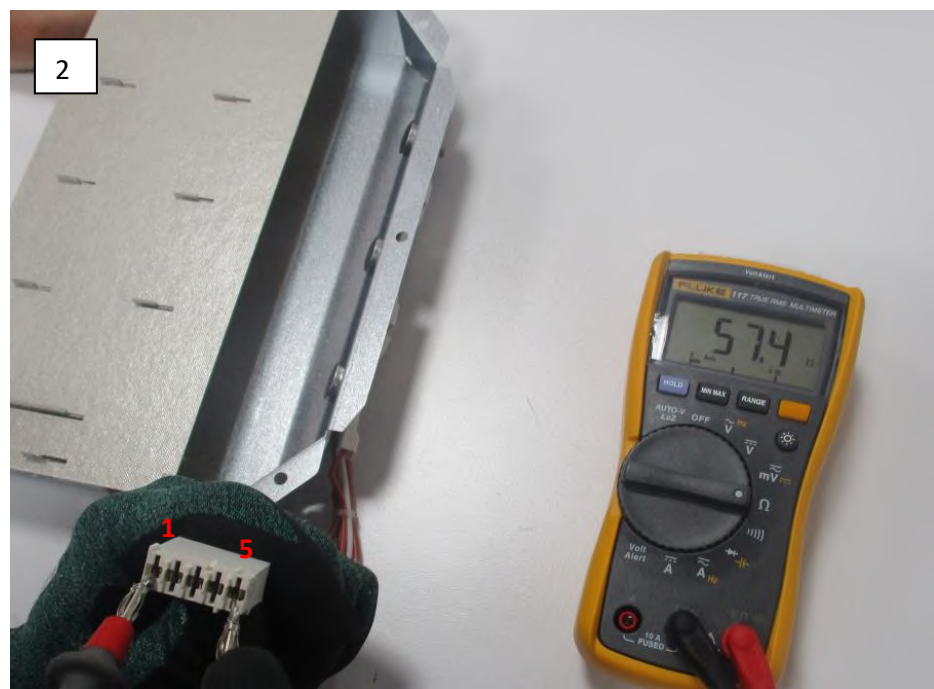

7.6. Door Latch

Door latch (switch) will be at “closed” position when the door is closed.
It’s designed to be opened from inside, in case of any children gets inside the drum



Component Test

- When the door is closed, check whether there is electrical transmission from IDC connected to electronic card (Buzzer mode should be selected on multimeter)
- Check the connection of the component connector

7.6.1 Door Latch Measurements



7.7. Humidity Sensor

The Humidity Sensor measures the amount of dryness of the laundry in the drum.



Component Test

- Each humidity sensor plate is checked whether there is electrical transmission from IDC connected to electronic card. (Buzzer mode should be selected on multimeter)
- Check the connection of the component connector

7.7.1 Humidity Sensor Measurements



7.8. Condenser

In the condenser, there are crossed channels that allow to flow the hot and cold fluid. Thus, They allow the hot air reach to the condenser and leave its humidity by cooling.



7.9. Drumlight

Drumlight illuminates inside of the drum



Component Test

Check whether there is electrical transmission from IDC connected to electronic card.

8. TROUBLESHOOTING

