



SECHE-LINGE

MANUEL DE SERVICE

BANDEAU F4B



CONTENTS

1. OVERVIEW AND WORKING PRINCIPLE.....	3
2. TECHNICAL SPECIFICATIONS.....	4
3. INSTALLATION.....	4
3.1. Issues that should be informed to customer	4
4. CONTROL PANEL AND PROGRAM SELECTION TABLE.....	5
4.1. Control Panel	5
4.2. Program List	5
4.3. Children’s Safety	6
5. FAILURE MODES AND SERVICE AUTOTEST	6
5.1. Failure Modes and Warning Leds.....	7
5.2 Service Auto Test Steps	8
6. DISASSEMBLY.....	9
6.1. Top Plate.....	9
6.2. Control Panel	10
6.3. Electronic Card	12
6.4. UI Card.....	13
6.5. Side Panel	14
6.6. Supply Cable.....	16
6.7. Emi Filter.....	17
6.8. Rear Cover	18
6.9. Air Guide Bracket	20
6.10. Heater.....	21
6.11. Rear Panel.....	26
6.12. Rear Isolation Group.....	30
6.13. Pump	31
6.14. Process Fan	34
6.15. Water Tank Housing	35
6.16. Drum.....	37
6.17. Capacitor.....	39
6.18. Motor.....	40
6.19. Belt	41
6.20. Humidity Sensor	42

6.21. Door Latch.....	43
6.22. Condenser Drawer Cover.....	44
6.23. Plinth.....	46
6.24. Plinth Cover.....	47
6.25. Door.....	48
6.26. Drum Bearing Wheel.....	49
6.27. Drumlight.....	50
6.28. Front Panel.....	51
6.29. NTC Sensor.....	52
6.30. Side Bracket.....	53
6.31. Front Shield.....	55
6.32. Front Isolation Foam.....	56
6.33. Cable Group.....	57
7. COMPONENT SPECIFICATIONS AND MEASUREMENTS.....	59
7.1. Motor.....	59
7.1.1. Motor Measurements.....	60
7.2. Pump.....	61
7.2.1 Pump Measurements.....	62
7.3. Electronic Card.....	63
7.4. Door/Heater NTC Sensor.....	64
7.4.1. Door NTC Sensor Measurements.....	65
7.4.2.Heater NTC Sensor Measurements.....	65
7.5. Heater.....	66
7.5.1. Heater Measurements.....	67
7.6. Door Latch.....	68
7.6.1 Door Latch Measurements.....	68
7.7. Humidity Sensor.....	69
7.7.1 Humidity Sensor Measurements.....	69
7.8. Condenser.....	70
7.9. Drumlight.....	70
8. TROUBLESHOOTING.....	71

1. OVERVIEW AND WORKING PRINCIPLE

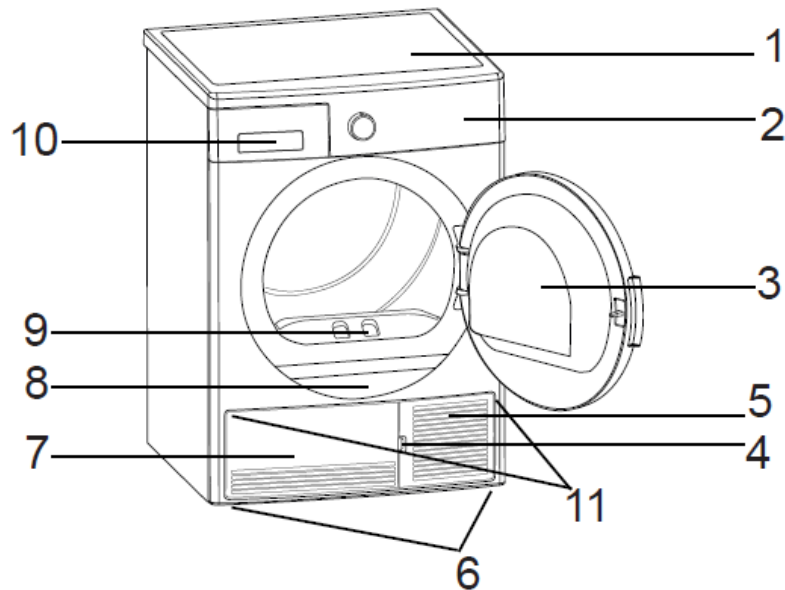

1. Top Plate
2. Control Panel
3. Loading Door
4. Plinth opening slot
5. Plinth
6. Adjustable feet
7. Plinth cover
8. Type plate
9. Lint Filter
10. Drawer cover
11. Ventilation Grills

Working Principle:

In the dryer machine, heated air is sent to the wet laundry in the drum. The humidity of the laundry is taken and reaches the condenser via filter. (At the same time, cold air taken from the environment is sent to condenser by the cooling fan. Thus, the condenser surface is cooled.) The hot and humid air from the drum is reached cold condenser surface and the humidity on it is left as water. The condensing water is collected at the pump reservoir and pumped to the water tank by the pump.

	F4 B PANEL	
	SERVICE MANUAL	

2. TECHNICAL SPECIFICATIONS

Manufacturer	Vestel White Goods	
Capacity (max)	7 kg	8 kg / 9kg
Height	Min: 845mm Max: 855 mm	Min: 845mm Max: 855 mm
Depth	563 mm	609 mm
Width	596 mm	596 mm
Net weight (with plastic door)	35,2 kg	36,5 kg
Net weight (with glass door)	37,5 kg	38,8 kg
Voltage	220-240 V	
Power	2700 W	
Supply Cord	H05V2V2-F 3G1,5 mm ²	
Working Temp.	+5°C - +35°C	

3. INSTALLATION

3.1. Issues that should be informed to customer

1. Drying machine must be grounded.
2. Lint filter must be cleaned after each use
3. Water tank must be unloaded after each use
4. Condenser must be cleaned once in a month
5. The amount of laundry should be appropriate to program.
6. Only the laundry with “suitable for drying” label should be dried.
7. Children should not play with appliance
8. Ventilation grills should not be closed.
9. The service life time of tumble dryer is 10 years.
10. Adjustable feet should not be removed.
11. There should not be lockable or sliding door in the installation area
12. Never spray or pour water onto the dryer to wash it. There is a risk of electric shock.

Please ensure that customer reads the user manual

1. Check the environmental conditions. **(Voltage, current etc.)**
2. Ensure that product is used correctly
3. Check the machine with **Service Auto Test**. If the system displays failure code, find the corresponding code in the failure code list then act according to this.
4. Check the electronic connections
5. Make sure that cables and hoses are organized

4. CONTROL PANEL AND PROGRAM SELECTION TABLE

4.1. Control Panel



Display Symbols

Water tank warning indicator	
Lint filter cleaning warning indicator	
Condenser cleaning warning indicator	

4.2. Program List

KNOB POSITION	PROGRAM
1	Cotton Super Dry
2	Cotton Cupboard Dry
3	Cotton Iron Dry
4	Synthetics Cupboard Dry
5	Synthetics Iron Dry
6	Delicate
7	Time Drying
8	Baby Care
9	Duvet / Jeans
10	Sport
11	Mix
12	Wool Refresh
13	Refresh
14	Jet Dry 29'
15	Shirts 12 '
16	OFF



***The machine has humidity sensor that detects whether the laundry dry or not. At the programs that work with humidity sensor laundry does not dry in fixed time. Duration is constantly updates according to humidity data taking from laundry.

*****Time Drying Program:** Humidity sensor is deactivated. The program ends when the time is up, without checking the humidity of the laundry.

*****Express 29' / Shirts 12 ':** Humidity sensor is activated. The program time may extend, if the customer use different laundry according to the load in the program description.

Express 29' : 2 kg of cotton shirts spun at a high speed in the washing machine are dried in 29 minutes.

Shirts 12' : 2 to 3 shirts are ready for to be ironed in 12 minutes.

*****Delicate:** Delicate fabrics are dried for a longer time at a low temperature.

4.3. Children's Safety

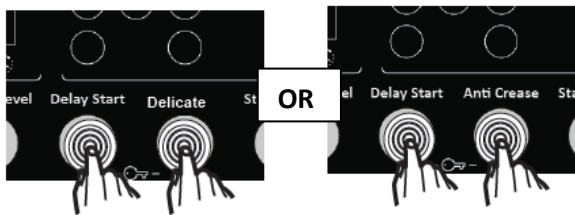

There is a child lock option to avoid changes in the program flow when keys are pressed during the program.

There are 2 version of the panels; which are Delicate or Anti Crease. To activate child lock,

If It is Anti Crease panel, press and hold "Delay Timer" and " Anti-Crease " keys simultaneously for 3 seconds.

If It is Delicate panel, press and hold "Delay Start" and "Delicate" keys simultaneously for 3 seconds

When the child lock is active, all keys will be deactivated. Child lock will be deactivated automatically at the end of the program. When activating/deactivating the child lock, the leds of the "Anti-Crease" and "Delicate Drying" options will flash and an audible warning will be heard.

5.FAILURE MODES AND SERVICE AUTOTEST

*****Service auto test must be run for every service call.**



5.1.Failure Modes and Warning Leds

The filter and condenser cleaning warning leds are flashing	The filter might be clogged by lint	Clean the lint filter.
	There might be a layer that causes obstruction on the surface of the lint filter.	Wash the lint filter with lukewarm water.
	The condenser might be clogged by lint	Wash and clean the condenser.



The case in the photo don't show us a failure code. (If it is don't blinking) Normally, when the drying program ends, the filter, water tank and end led are flashing. In addition, condenser cleaning warning led is on every 30 cycles.

F4/F4T CONDENSER MODEL ERROR CODES	
ERROR CODE	REASON
E00	F4 Touch UI board doesn't receive communication from mainboard
E03 / 	Aquaswitch connector is disconnected
E04	Heater connector is disconnected
E05	Heater NTC connector is disconnected
E06	Door NTC connector is disconnected
E08	Voltage fluctuation

Notes For Service autotest:

*Service can not pass the current step before completing the minimum duration

*When minimum duration for each step (5 sec) is completed, filter led makes **slow blink** to indicate that service can pass the next step

*For error codes, leds must make **fast blink**

*****Power analyzer must be plugged and machine is connected to this analyzer.**

5.2 Service Auto Test Steps

Steps	Control	Led	Possible Errors
Enter Servis Autotest	<p>While pushing SW2 button for 5 sec, position knob to Program 1. Then press Start/Pause button. Machine enters to service autotest. All warning leds makes fast blink for 2 sec and then becomes fix off</p> <p>Machine will show the last error.</p> <p>When knob positioned to program 2, control steps starts.</p>		
Step 2 (Knob Position 2)	Software check Aqua switch	E03	Aqua switch connector is taken out Aqua switch connector is short circuit Styrofoam is broken or not
Step 3 (Knob Position 3)	Pump activation is checked by service person	-	Service must pour water to pump reservoir and check whether water is pumped to tank. If water is not pumped to water tank; Pump connector is taken out
Step 4 (Knob Position 4)	Motor motion is checked by service person Motor CCW (Drum CW)-Motor stops	-	Service must check whether drum is moving to CW. If not; Motor connector is taken out Motor might be locked Motor belt might be dislocated
Step 5 (Knob Position 5)	Motor motion is checked by service person Motor CW (Drum CCW) -Motor stops	-	Service must check whether drum is moving to CCW If drum is moving to CW again, then motor relay short circuit CCW
Step 6 (Knob Position 6)	Software checks heater NTC	E05	Heater NTC connector is taken out or short circuit
Step 7 (Knob Position 7)	Software checks door NTC	E06	Door NTC connector is taken out or short circuit
Step 8 (Knob Position 9)	Heater power is checked by using energy analyzer by service Resistance (1600W+900 W)- Motor CCW (Drum CW) -motor off	-	Power of heater must be checked according to voltage of home***
Step 8 (Knob Position 9)	Service person check conductivity sensor when door is opened and motor is off by putting his hands on the conductivity sensor	E01	Service puts his hand on the humidity sensor plates and software checks sensor data If sensor data=0, humidity sensor connector is taken out

6. DISASSEMBLY

6.1. Top Plate

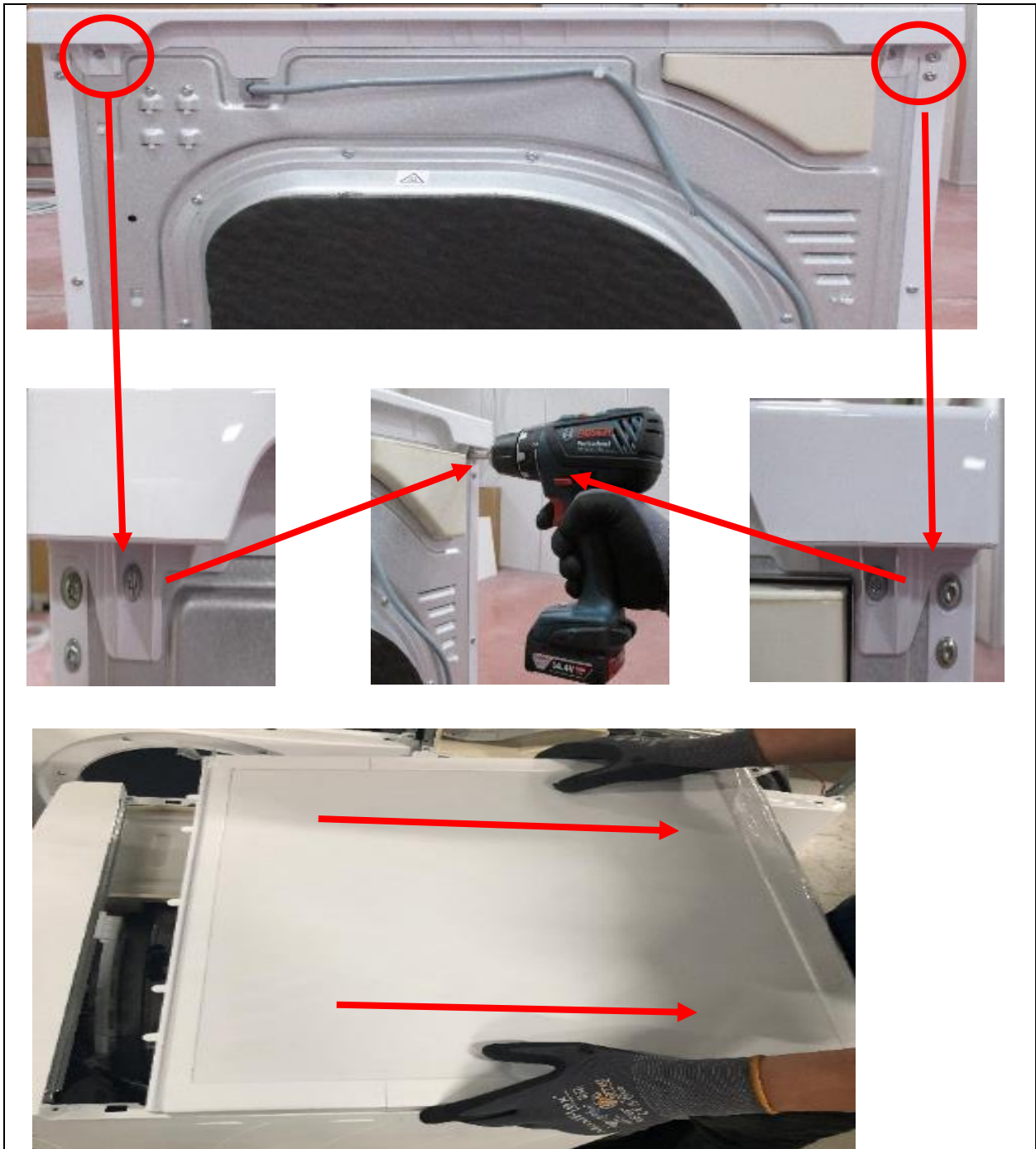

1. Remove two screws that fix the top plate at the back.
2. Remove by pulling the top plate to yourself.

6.2. Control Panel



1. Remove 2 screws from the top.
2. After disassembly the water tank , remove 1 screw from front

6.2. Control Panel

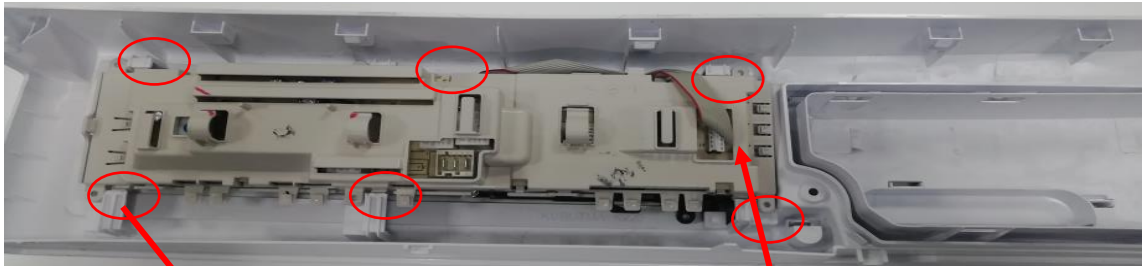

1. All sockets are removed from control panel
2. The cables on the control panel are carefully removed from the cable paths.
3. Remove the PCB box by pressing clips which provide fixing to panel So, PCB box will be separated from control panel

6.3. Electronic Card

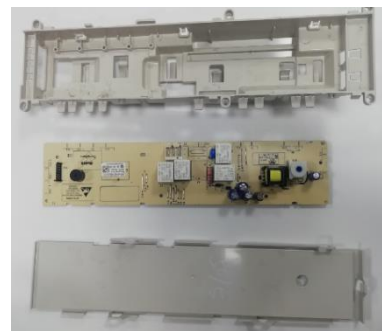
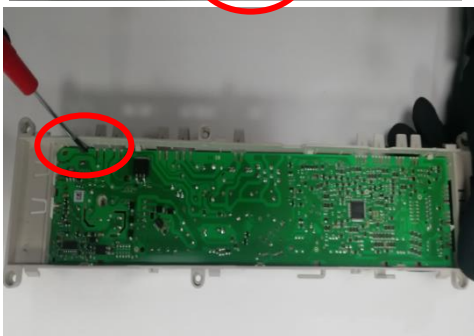
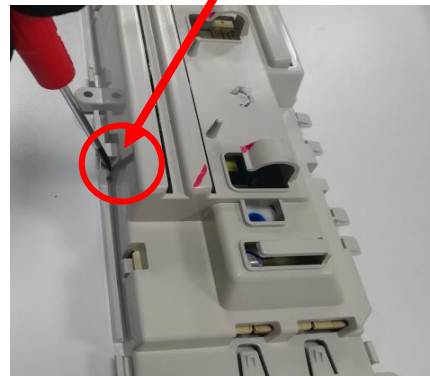
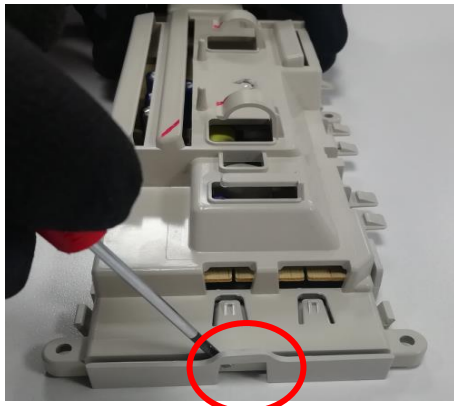
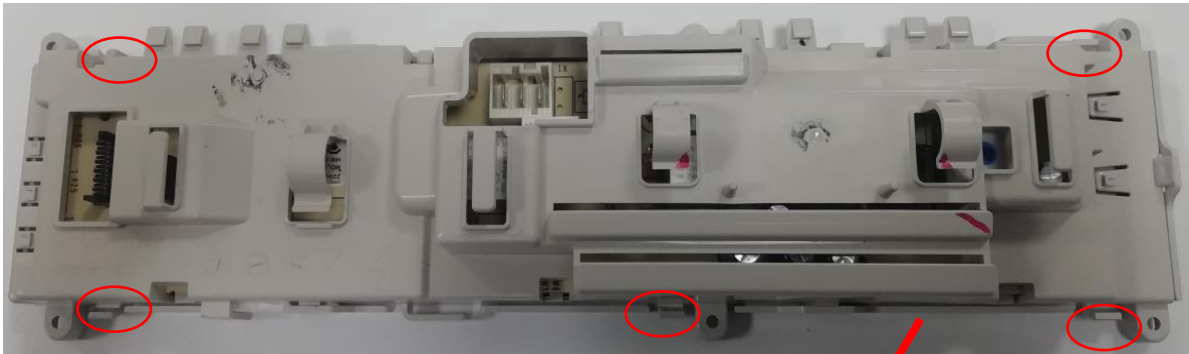

1. For opening the PCB box, press the clips (6 units) Care should be taken not to break the clips here.
2. The electronic card inside is removed from the nails. Remove the electronic card from pcb box as shown in the photo

6.4. UI Card

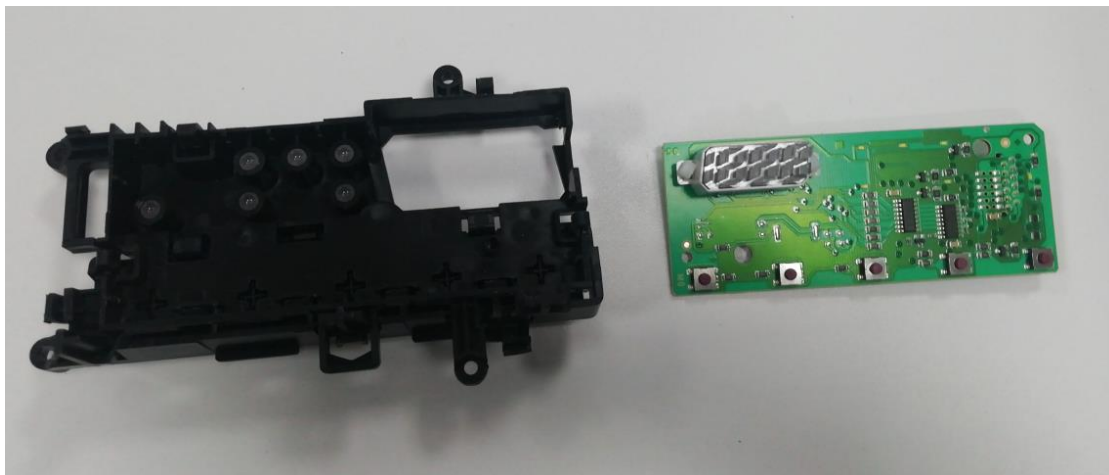

1. Remove screw on UI card as shown in photo.
2. UI card on control panel is disassembled as shown in photo. UI card has frame and 1888 light guide.

6.5. Side Panel

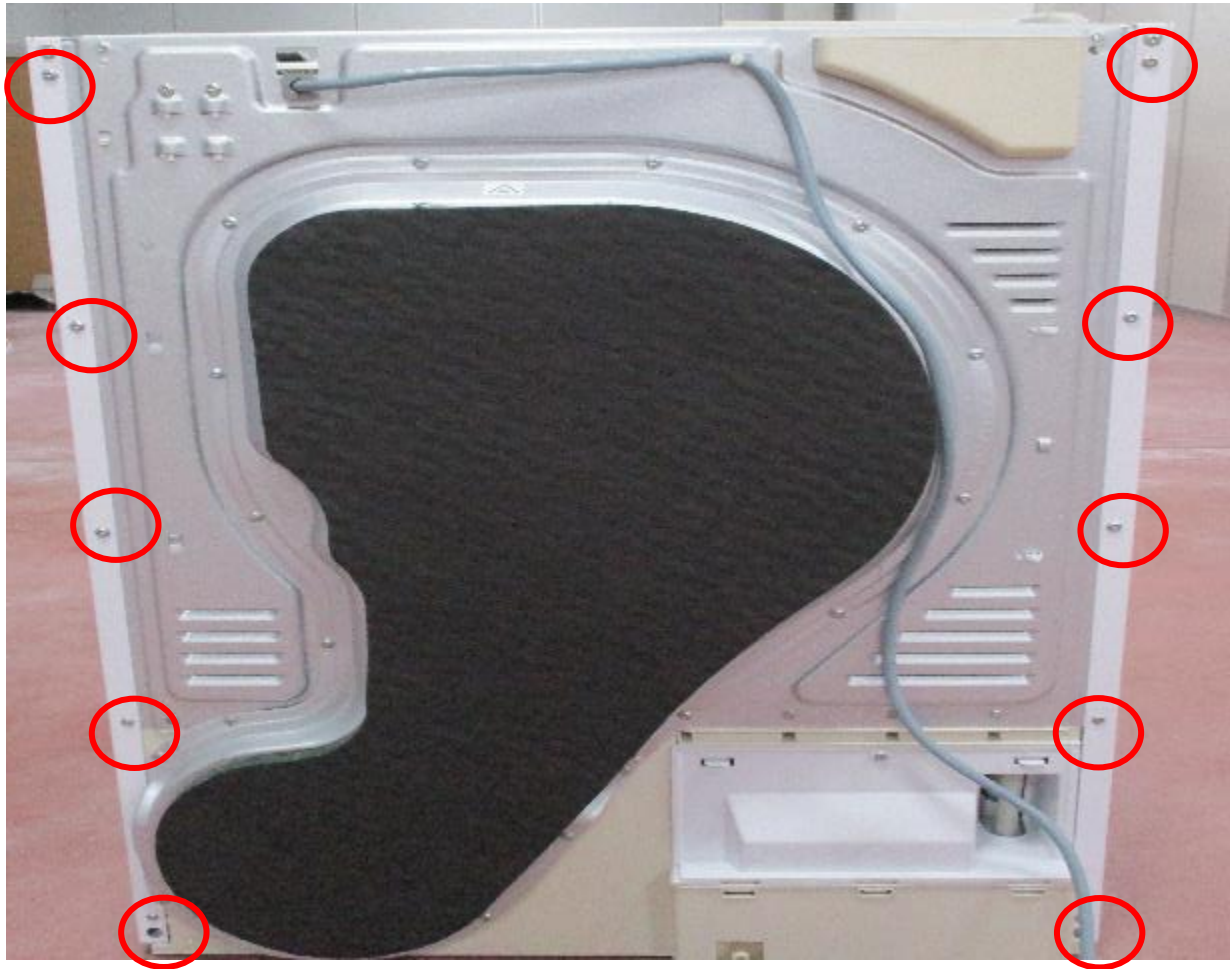

1. To remove the side panels, first remove the 5 screws for each panel at the back.

6.5. Side Panel

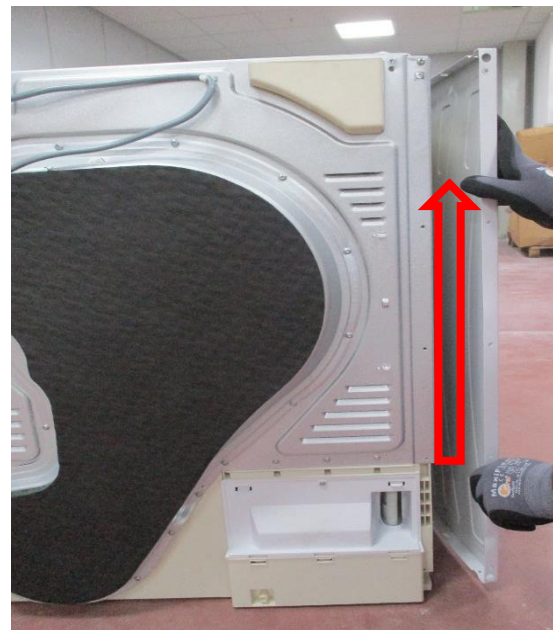

2. 2 Screws fixed to front bracket with side panels are removed for both panels.
3. 2 Screws fixed to basement plastic with side panels are removed for both panels.
4. Side panel must be removed by sliding it up as shown in the picture

6.6. Supply Cable

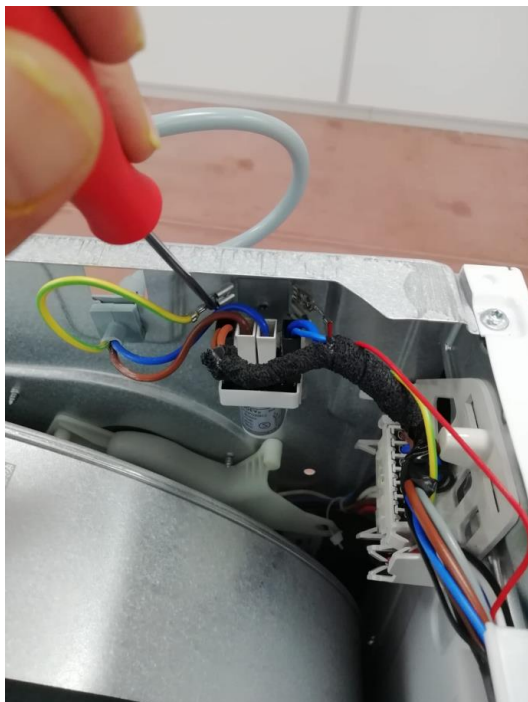

5. Remove the supply cable brown and blue cable socket.
6. Remove the terminals with tool as shown in the photo
7. Remove supply cord by pushing up

6.7. Emi Filter



1. There are two heater cable sockets on the outside of the EMI filter, and two power supply sockets (brown left-blue right) on the inside of the EMI filter. They are removed.
2. Remove grounding cable
3. Remove the screws on EMI filter.

6.8. Rear Cover

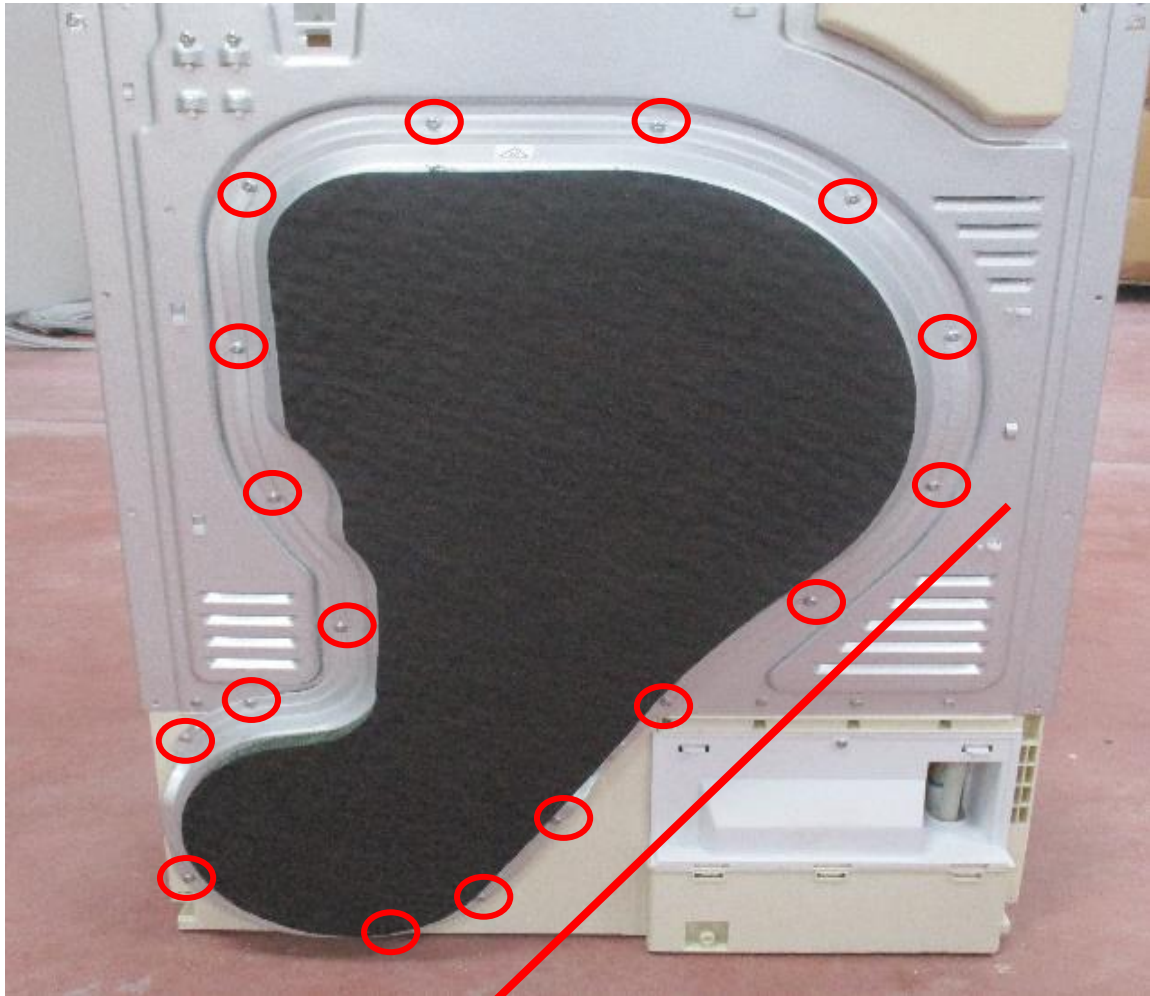

1. Remove all screws on the rear cover shown in the picture.

6.8. Rear Cover



2. Disassemble the rear cover after the screws have been removed.

6.9. Air Guide Bracket



1. Remove 4 screws of air guide bracket located under the heater

6.10. Heater

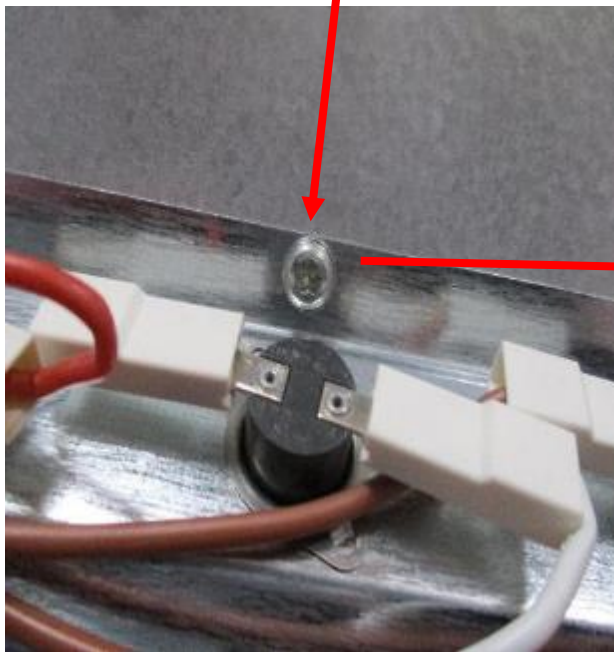
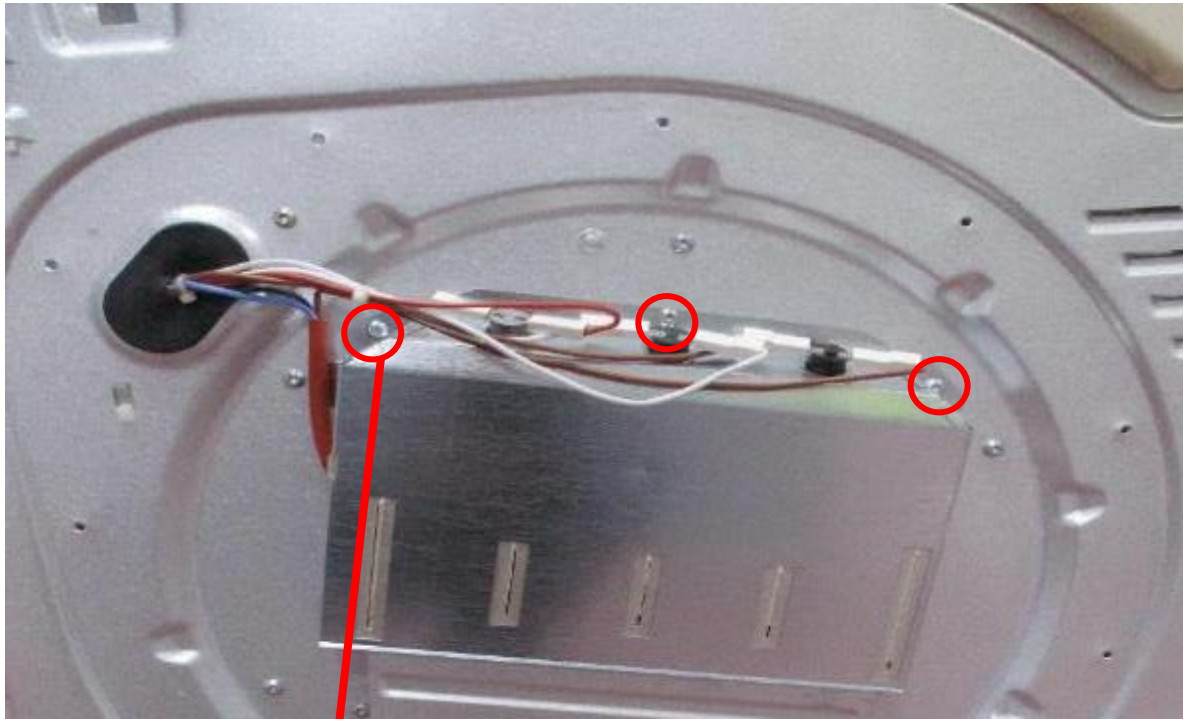

1. Disassemble the heater by removing 3 screws on heater

6.10. Heater

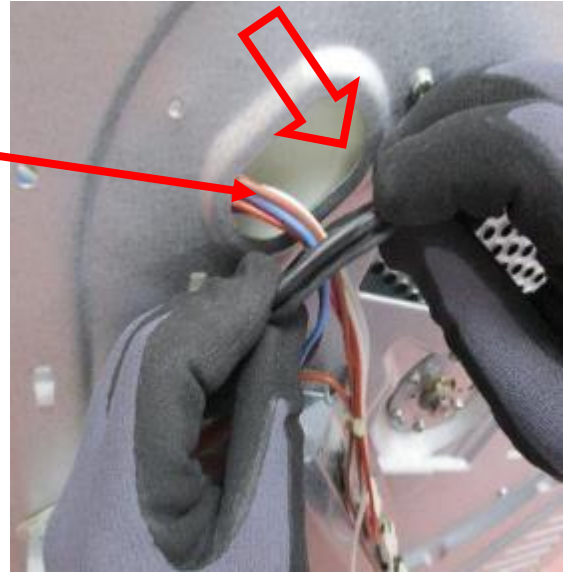

2. In the rear panel, the gasket on the cable group is removed.
3. The heater cable holder screw is removed.

6.10. Heater

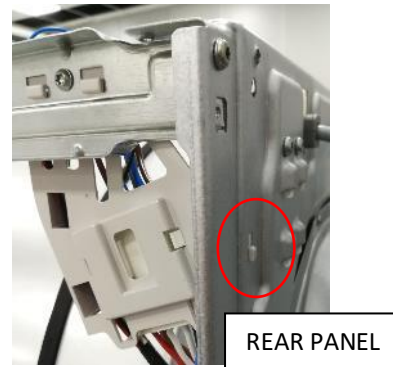
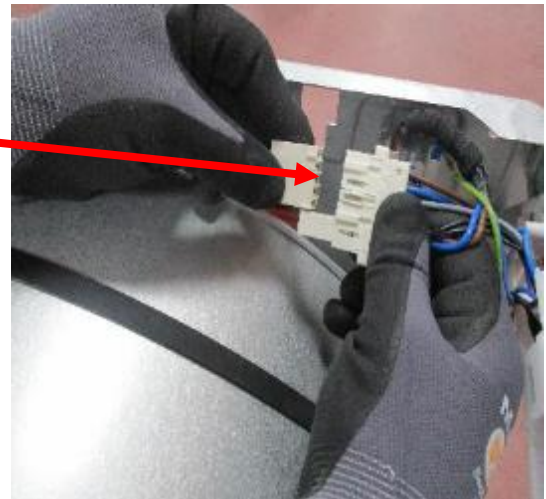
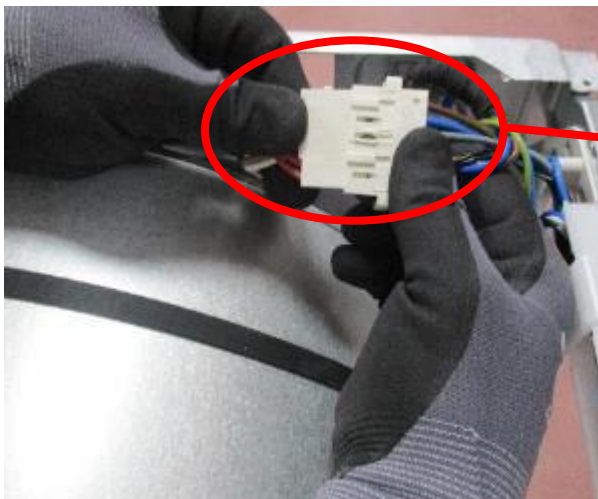
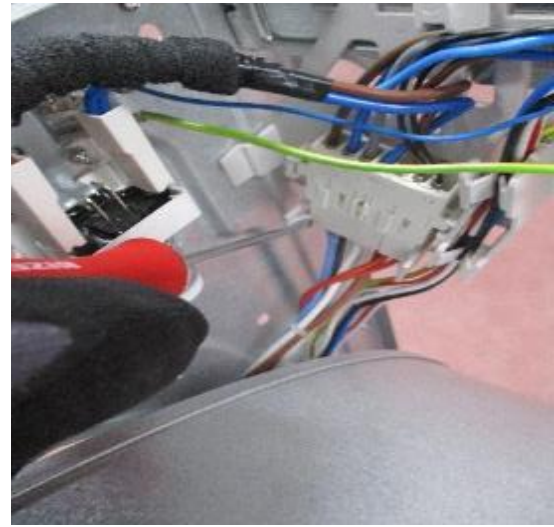
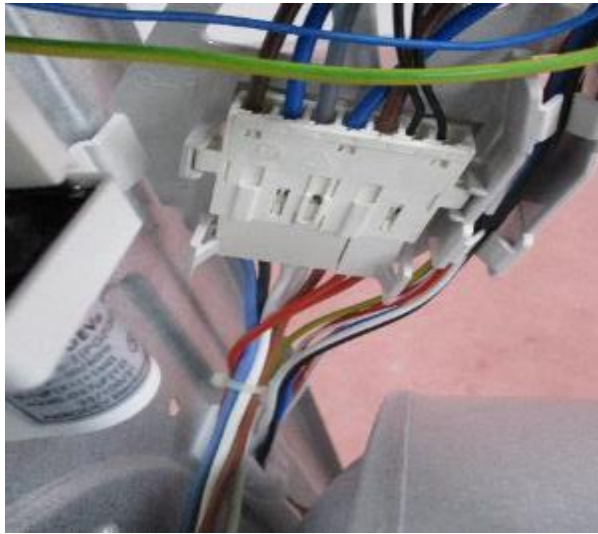

4. Remove the heater cable group from connector and cable holder plastic.
5. Heater cable holder also fixed by attachment on rear panel. After the reassembling, the attachment on rear panel must be checked.
6. The heater is disassembled

6.10. Heater

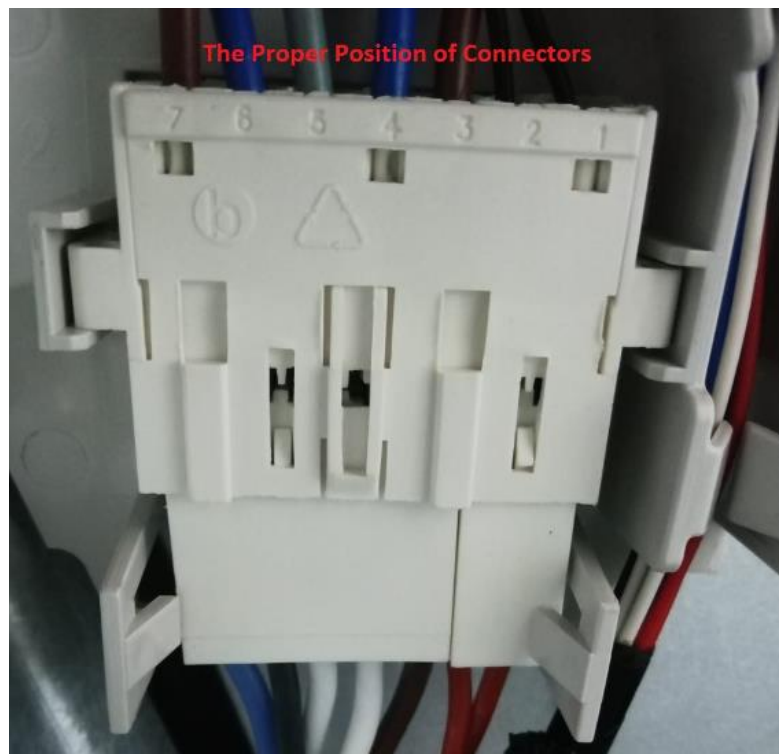
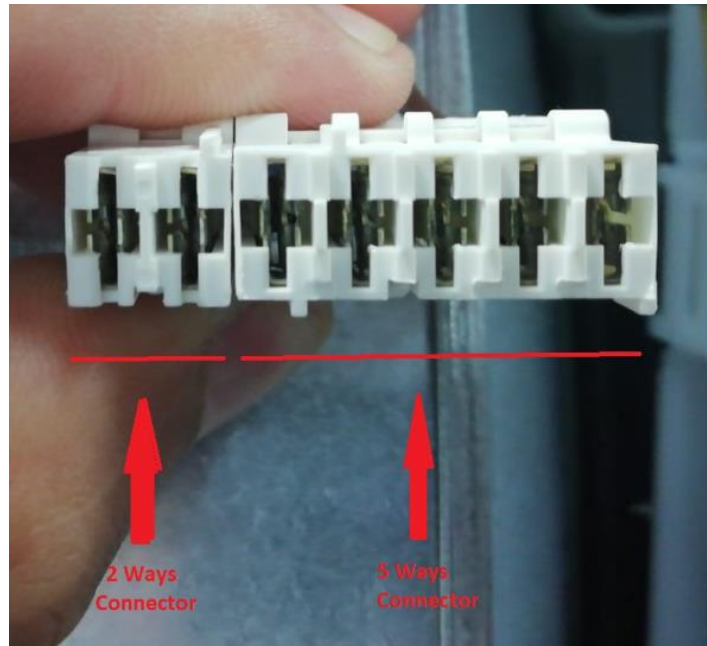

After the reassembling; position of the heater socket is important. 2 ways connector and 5 ways connector should be fixed properly.

6.10. Heater

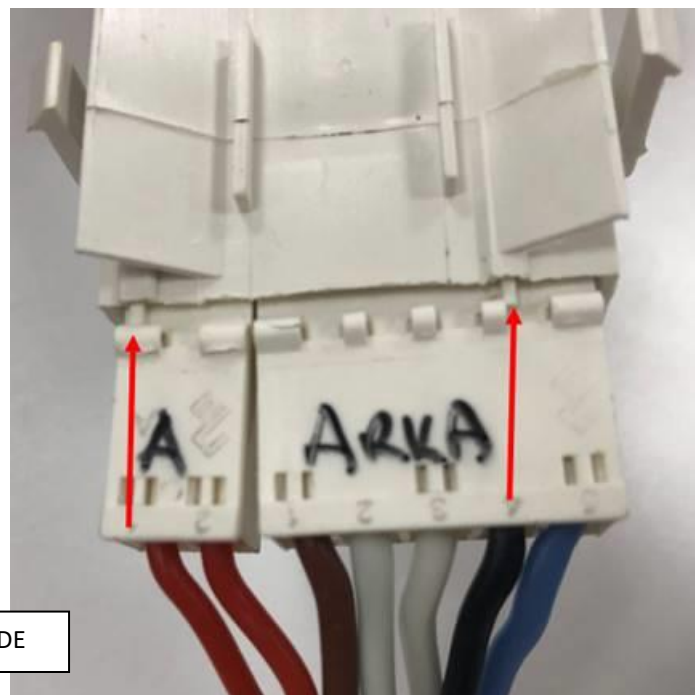
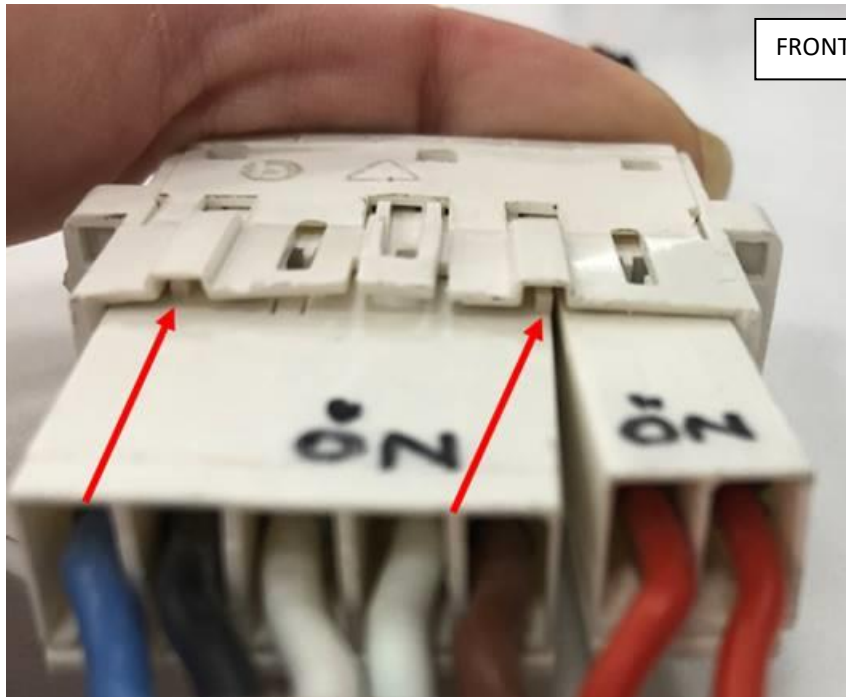

As shown in the photo, there are poka yoke on the sockets to avoid improper installation.

6.11. Rear Panel



1. Remove the screws on rear panel.

6.11. Rear Panel

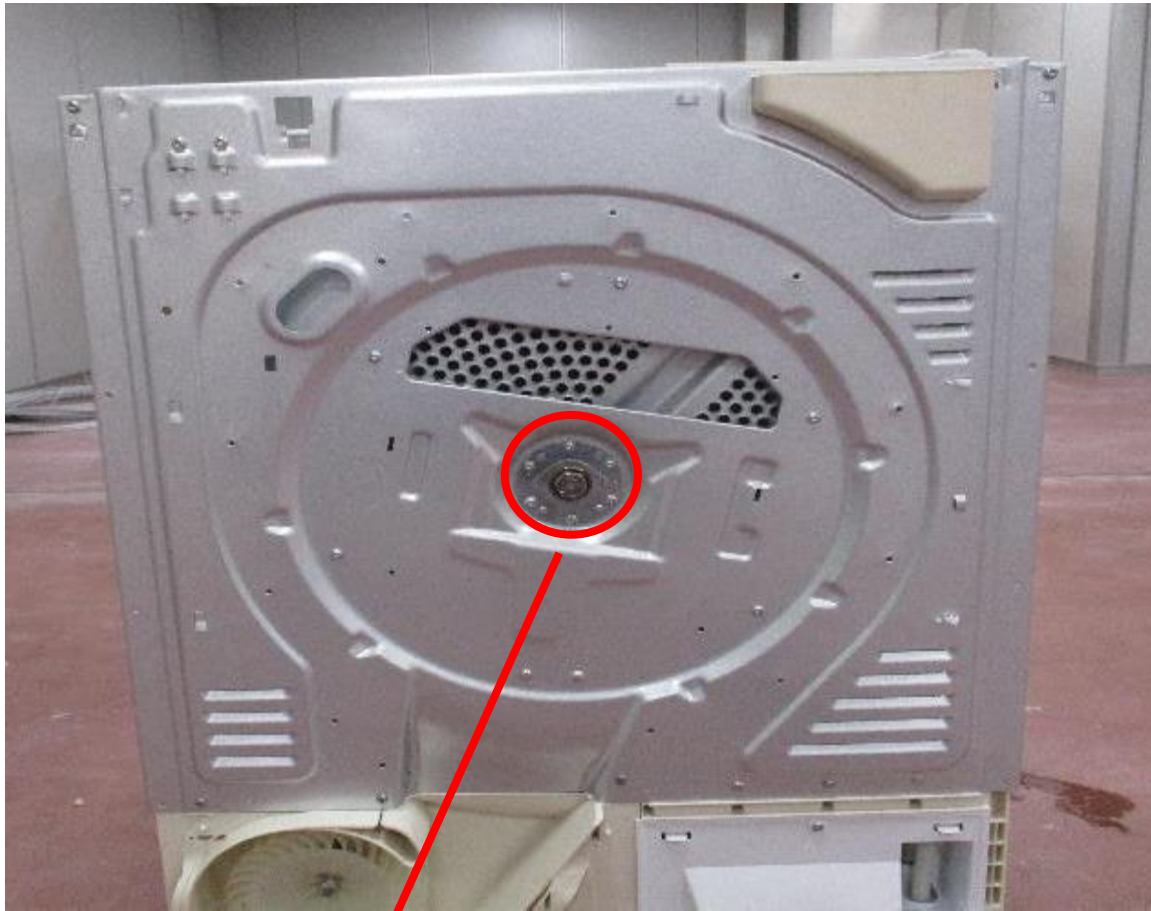

2. Remove the segment on drum shaft.

6.11. Rear Panel

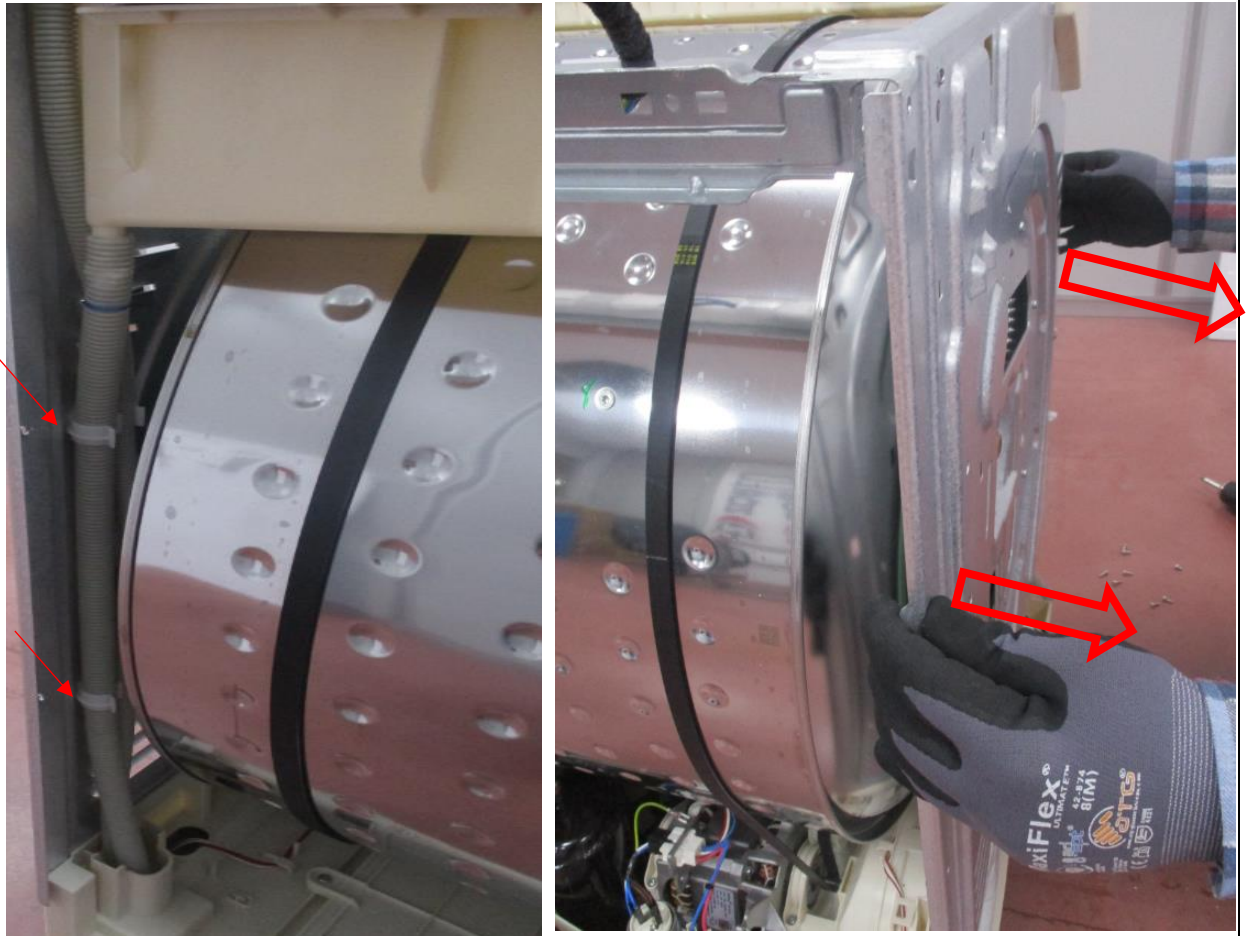

3. Remove hoses from rear panel
4. Remove the rear panel by pulling to yourself.

6.11. Rear Panel

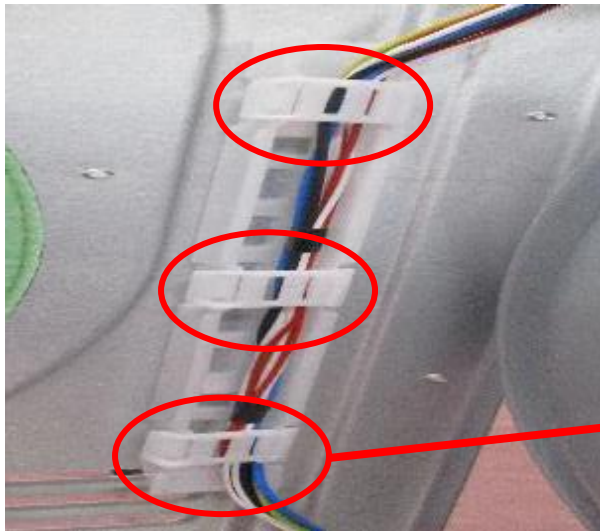

5. Remove the cable group by opening the cable holder plastic canal.

6.12. Rear Isolation Group

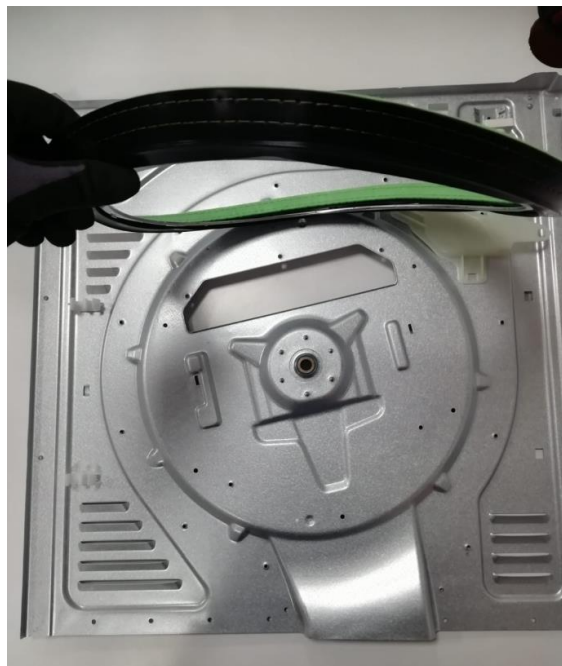

1. For disassembling the rear Isolation group on rear panel, screws are shown in the photo should be removed.

6.13. Pump

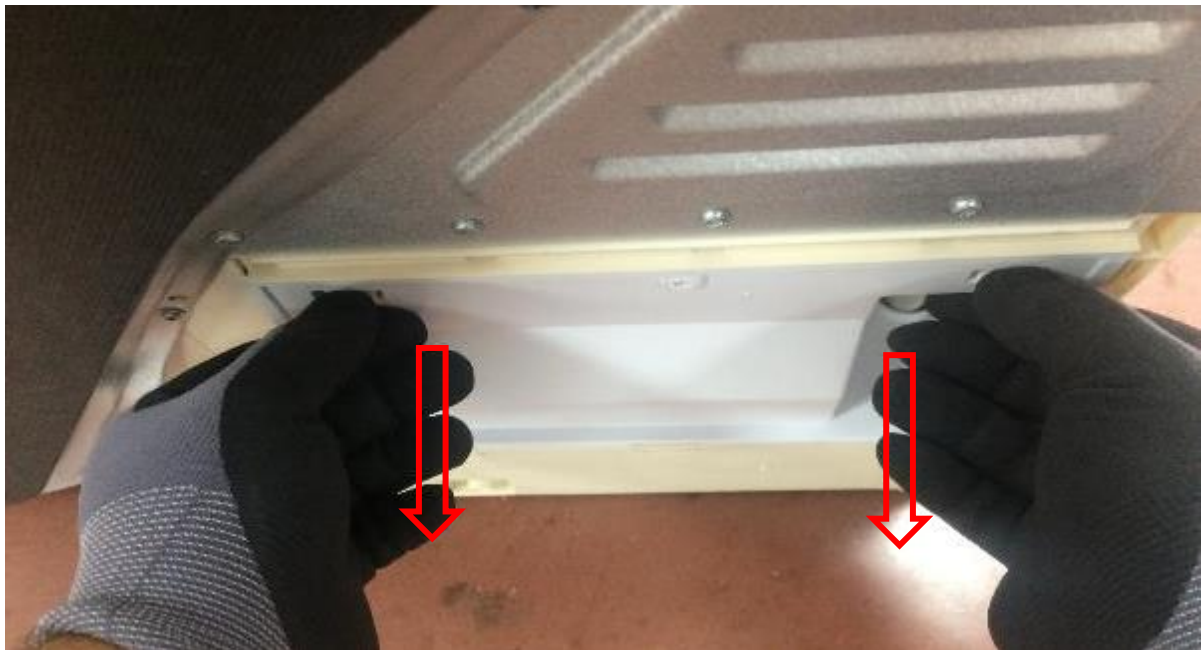

2. Remove the screw on pump cover
3. Open pump holder plastic cover

6.13. Pump

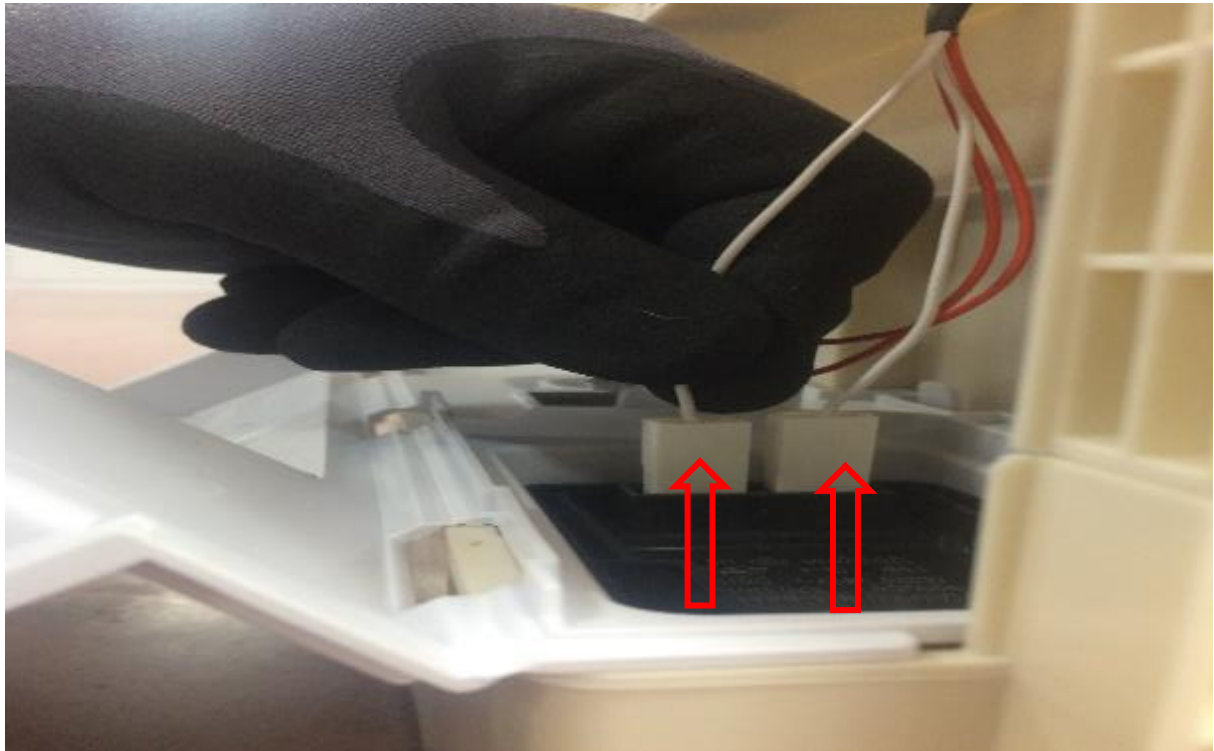

4. Remove pump connector
5. Remove connection of aqua switch

6.13. Pump

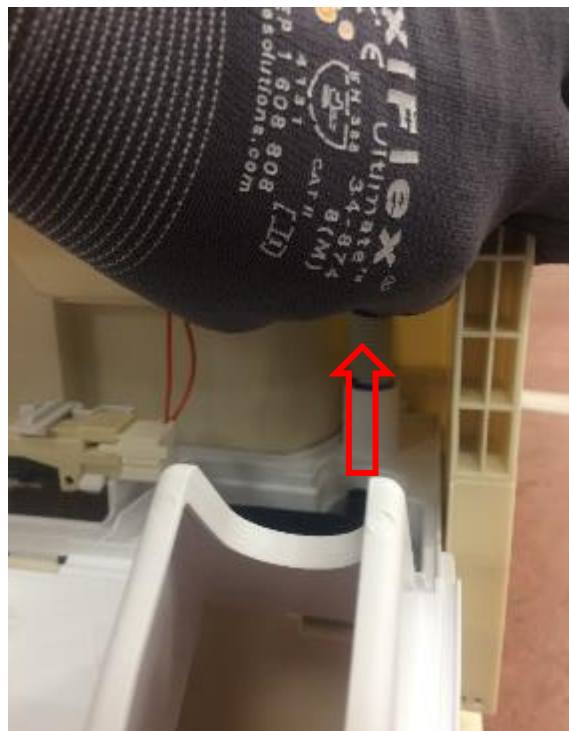

5. Remove 2 hoses that is connected with pump
6. Remove pump holder plastic by

6.14. Process Fan

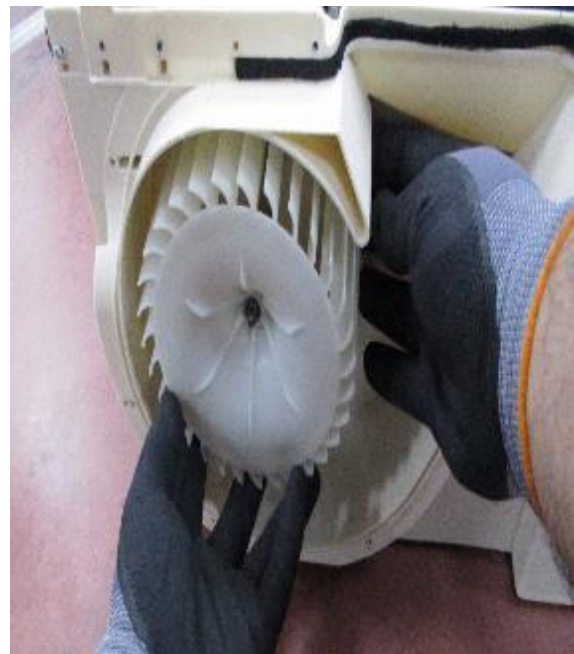

1. Remove the process fan by holding fan as shown in the photo.
2. For process fan disassembly, nut and flake should be removed. While cooling fan holding, sharp object should not be used.

6.15. Water Tank Housing



1. Remove Suction and Pressure hoses as shown in the photo.

6.15. Water Tank Housing

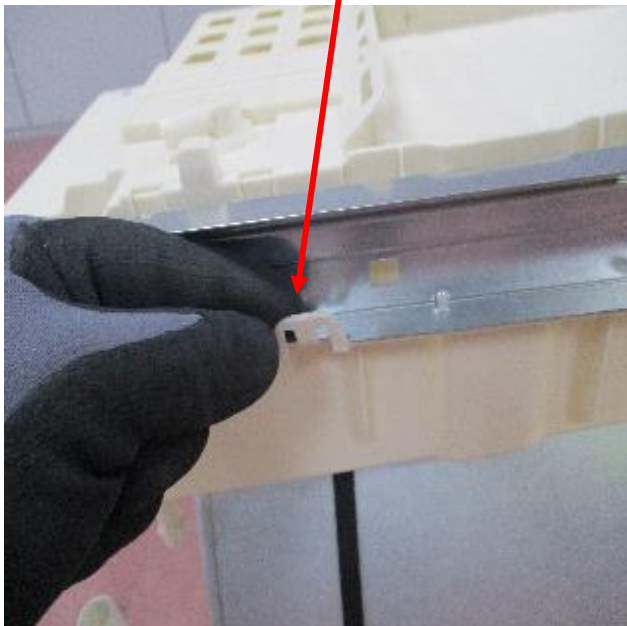
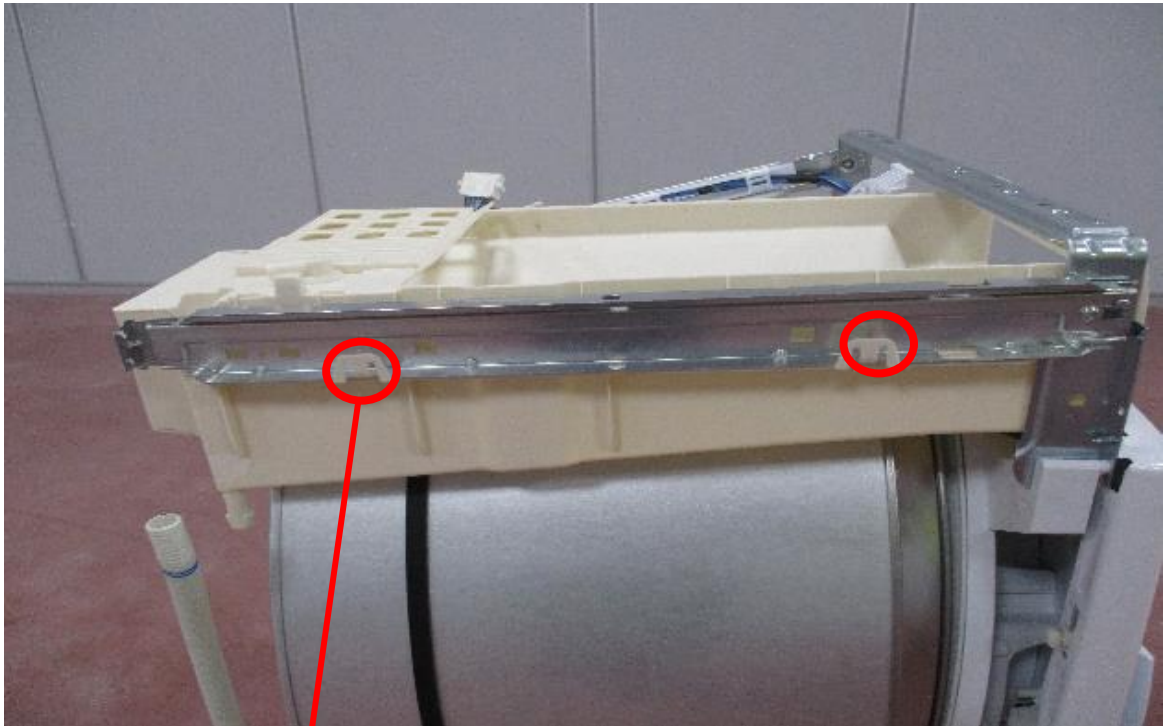

2. Clips fixed to water tank housing with side bracket are removed.
3. Remove water tank housing as shown in the photo

6.16. Drum

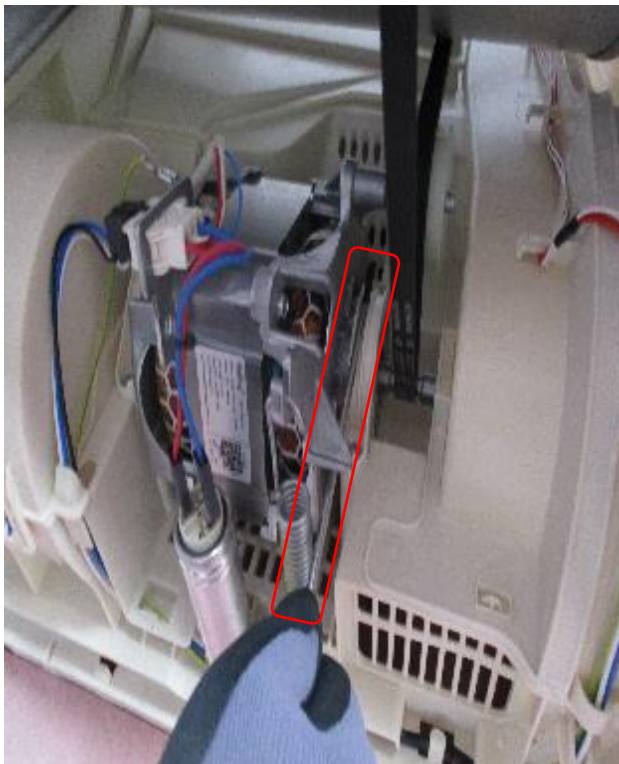

1. Motor should be moved up to prevent to press spring. So, belt will be released as shown in the photo.
2. Spring must not be stretched more than 40 mm. End and beginning of the spring must not be deformed.

6.16. Drum

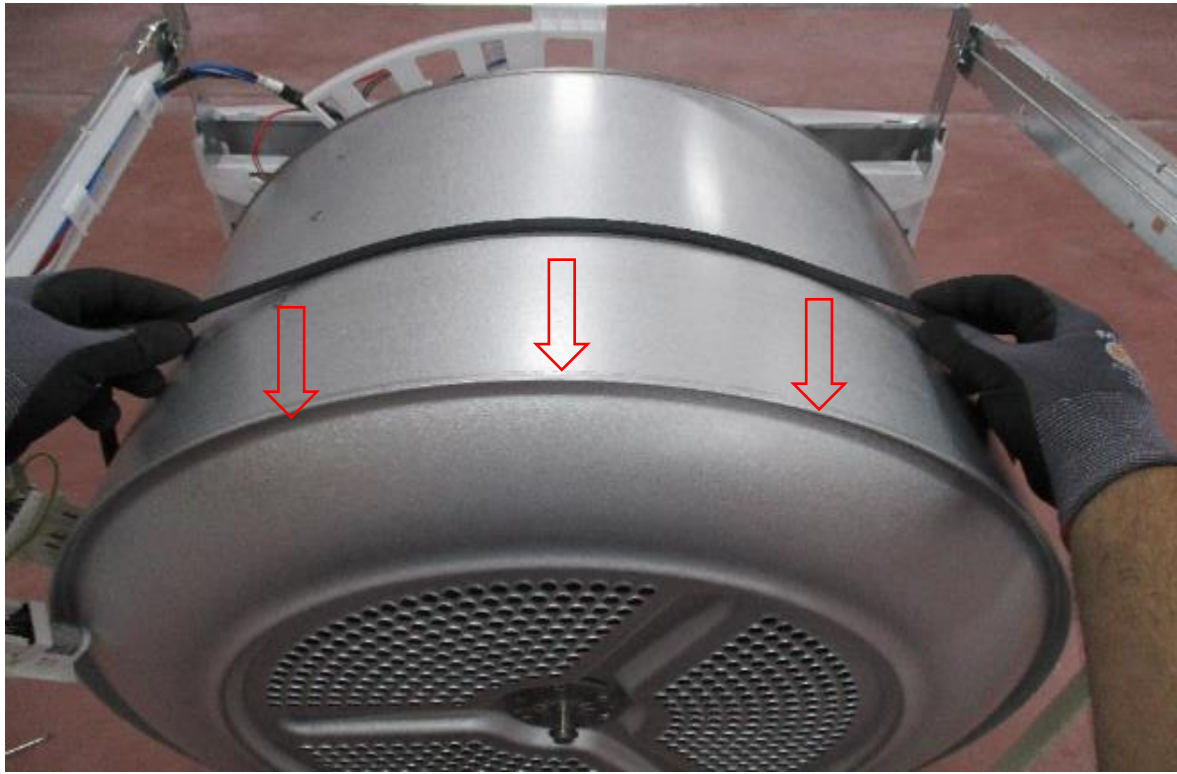

3. Remove the belt on the drum.
4. Pull up the drum to separate with basement plastic. Then, pull back to remove

6.17. Capacitor

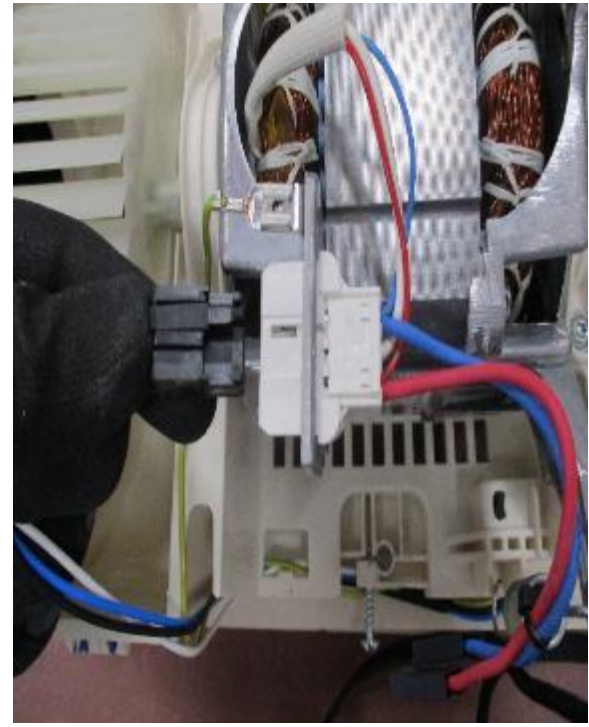
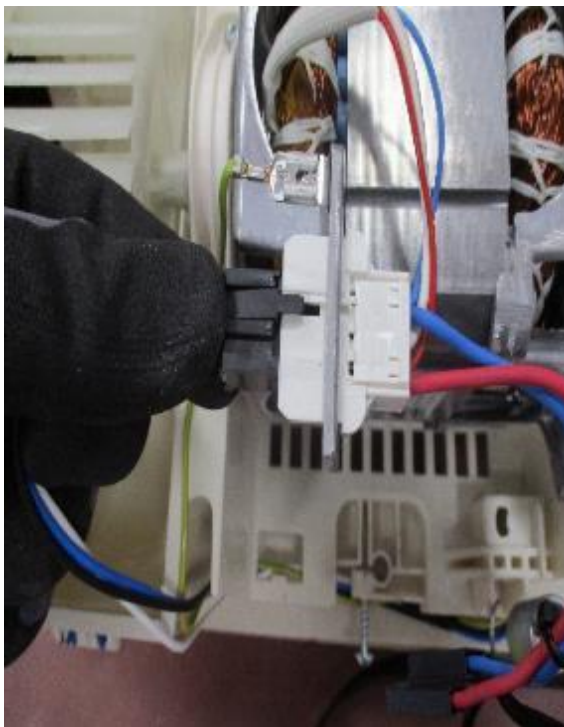
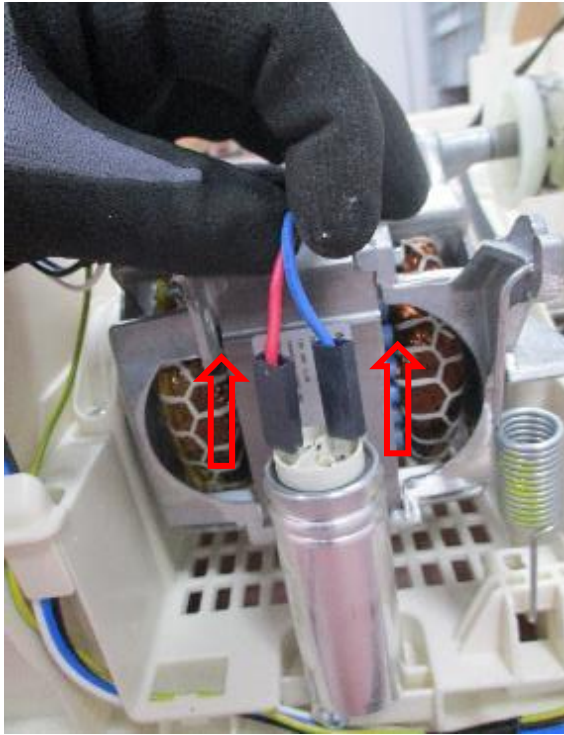

1. Remove capacitor sockets
2. Remove the screw on bottom of capacitor then disassemble the capacitor
3. After, you can remove the motor sockets for disassemble the motor.

6.18. Motor

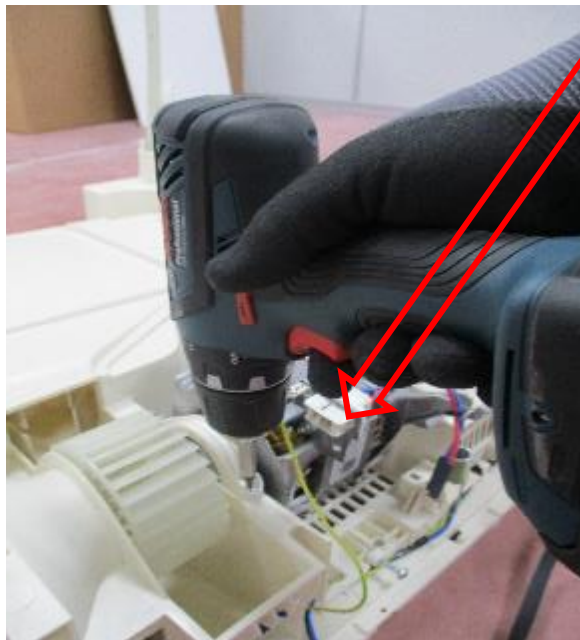
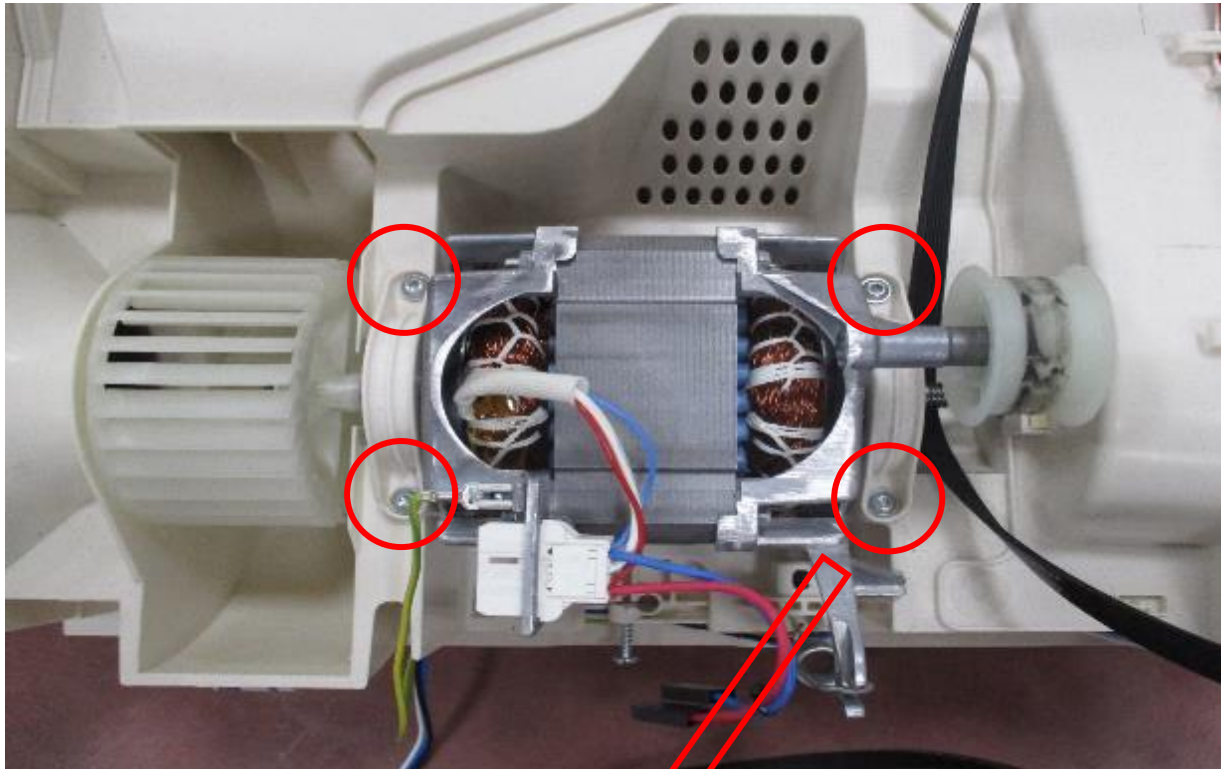

4. Remove screws on motor fixing plastics.
5. Remove the motor by pulling up

6.19. Belt



1. After you should remove drum and motor than change the belt.

6.20. Humidity Sensor



1. Screws of humidity sensor plastic are removed.
2. Remove humidity sensor cable as shown in the photo.
3. Remove humidity sensor sheet holder plastic

6.21. Door Latch

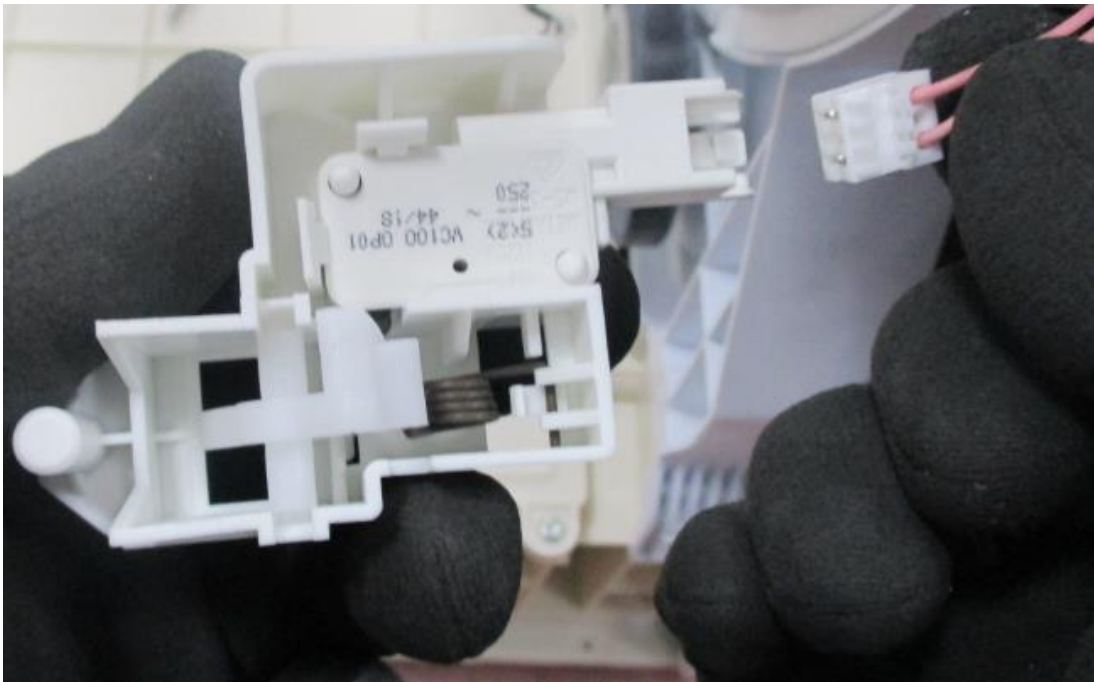
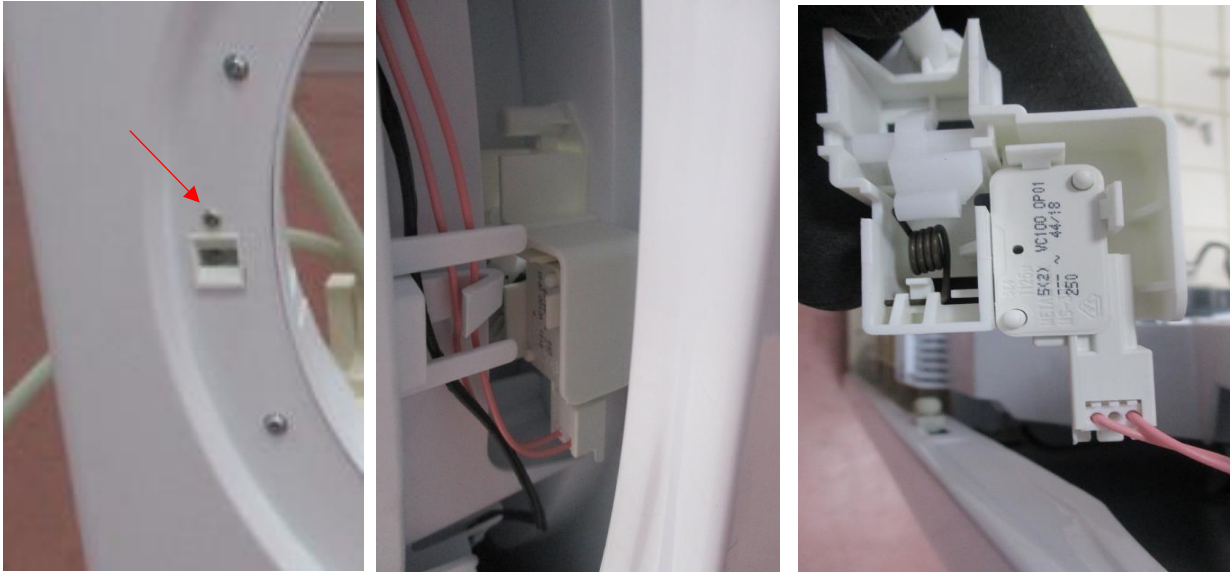

1. Remove door latch screw from front panel.
2. Separate the door latch socket from door latch as shown in the photo.

6.22. Condenser Drawer Cover



1. Open the condenser drawer cover lock plastic, then pull back the condenser.

6.22. Condenser Drawer Cover

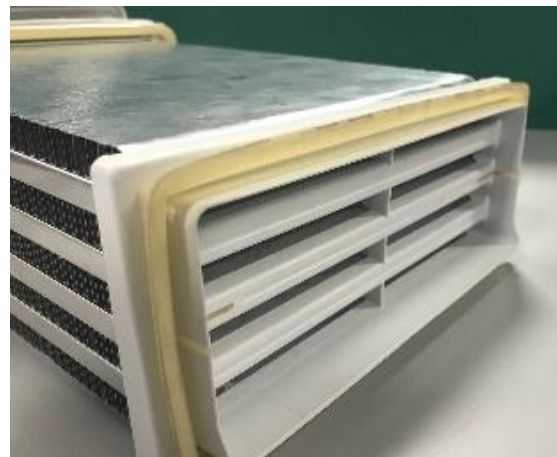

2. The clips around the condenser removed from the slot, as shown in the photo.
3. After remove the cover, cassette part remains from condenser.

6.23. Plinth



1. Remove 2 plinth pin on plinth cover as shown in the photo.

6.24. Plinth Cover

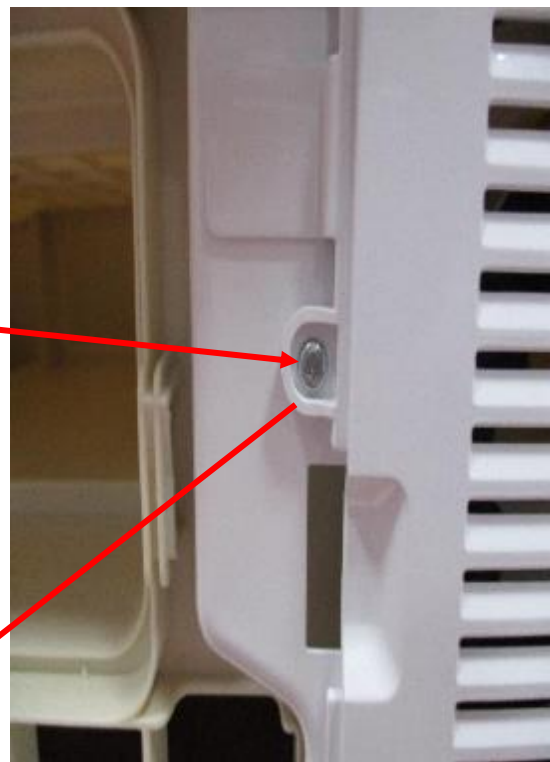

1. Remove the screw on plinth.
2. Disassemble the plinth by remove the attachment of plinth.

6.25. Door



3. Remove two screws on door hinge.
4. Pull the door as shown in the photo.

6.26. Drum Bearing Wheel



1. Remove wheels as shown in the photo

6.27. Drumlight

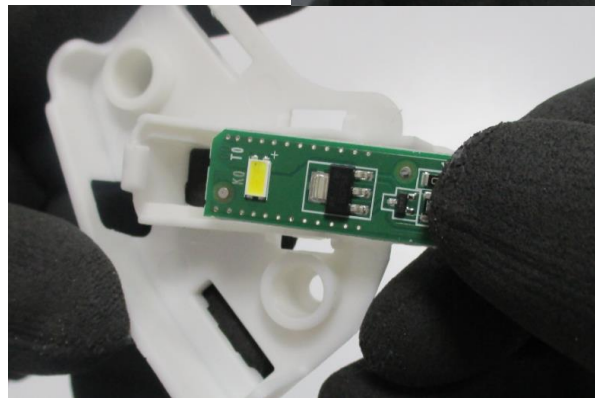
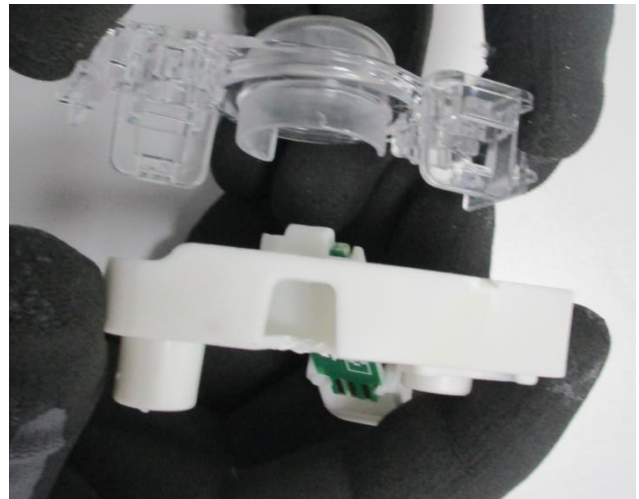
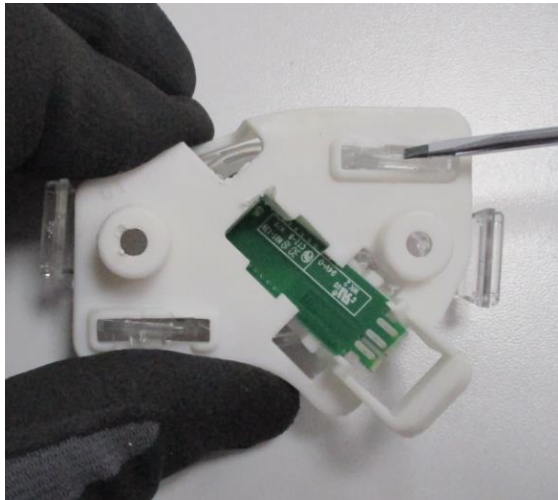

1. Remove Drumlight group from Front Shield
2. Remove the drum light socket.
3. Remove the drum light card.

6.28. Front Panel

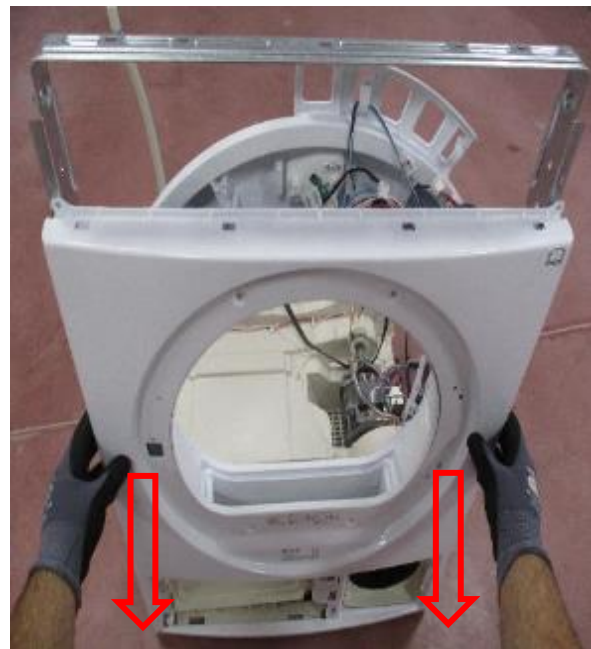
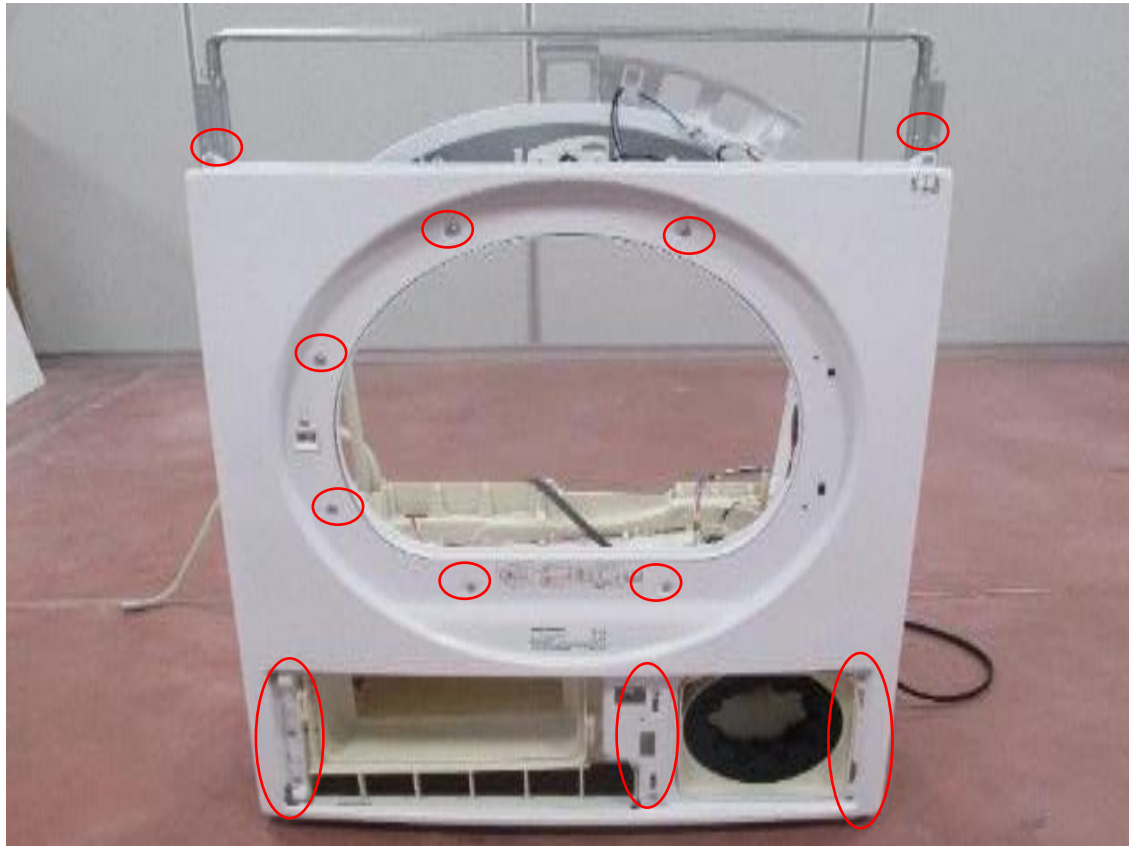

1. All screws on front panel are removed.
2. Pull back the front panel to remove

6.29. NTC Sensor

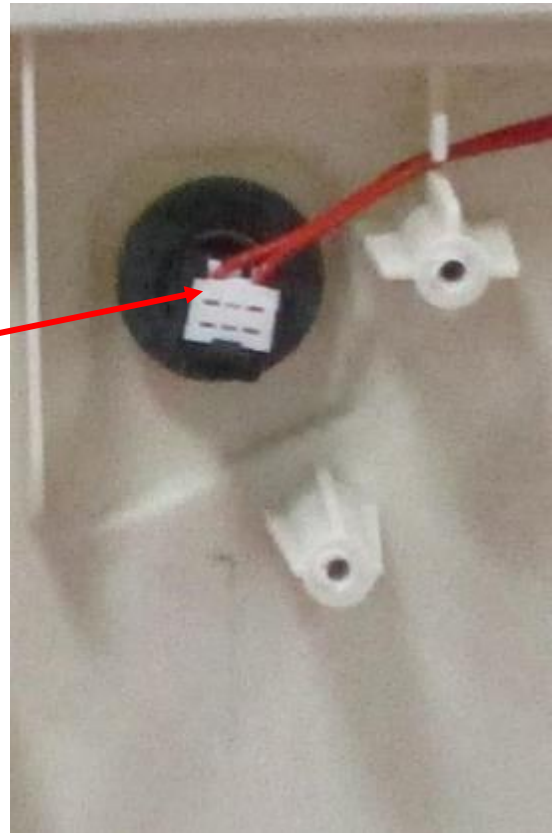

1. Remove NTC sensor socket.
2. Pull back the sensor from basement plastic.

6.30. Side Bracket

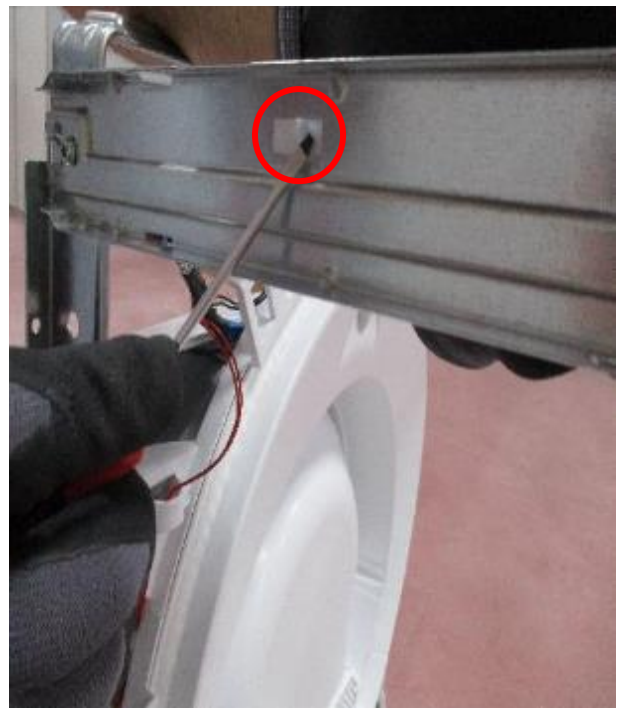
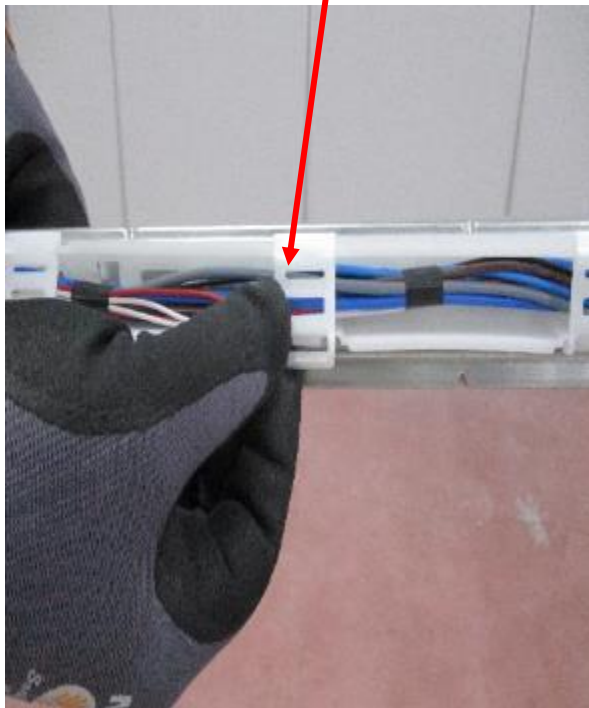
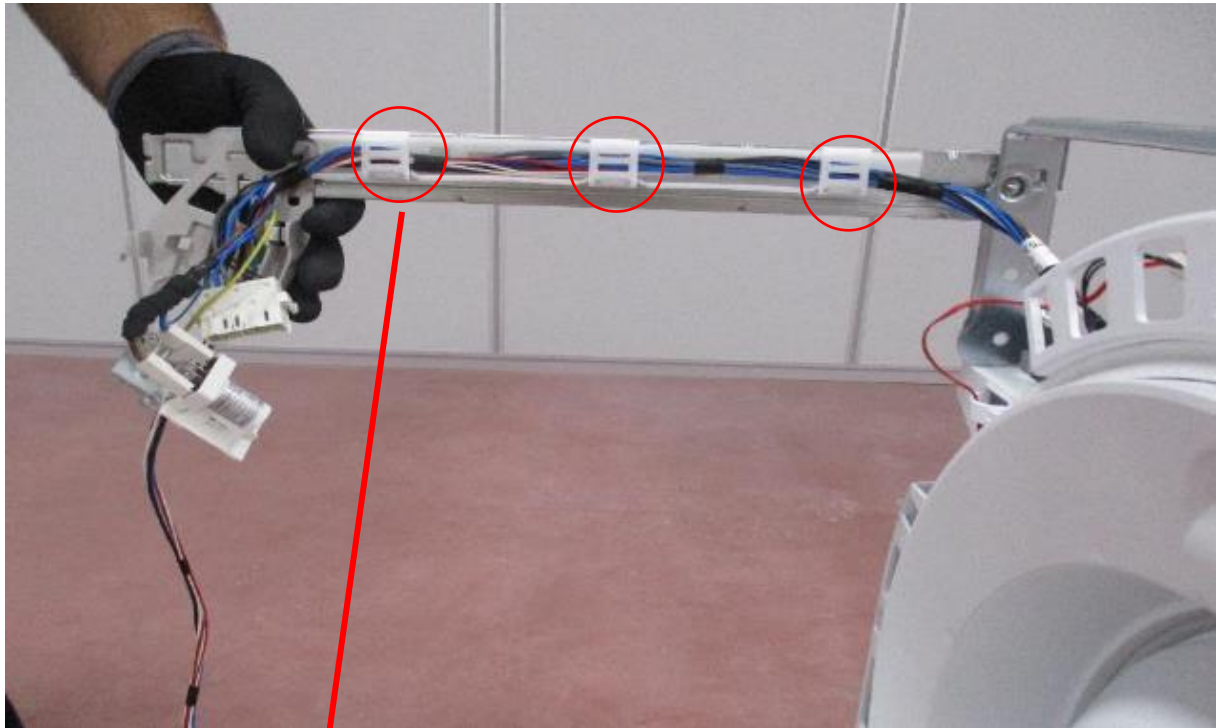

1. Open clips of the side cable holder plastic canal.
2. Clips fixed to bracket with cable holder plastic canal are removed as shown in the photo.

6.30. Side Bracket

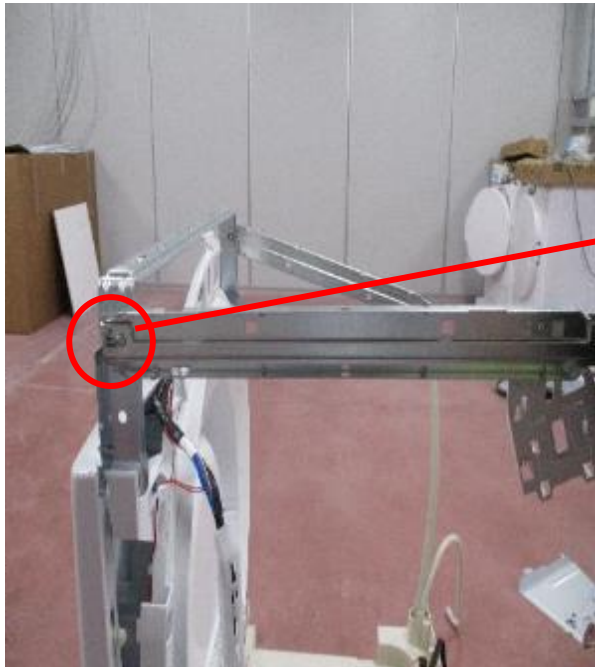

1. Remove the heater cable holder plastic.
2. The screw fixed to side bracket with top bracket is removed.

6.31. Front Shield



1. Remove two screws fixed of front shield with basement plastic.
2. Open clips on the left side as shown in the photo .
3. Front shield is lifted as shown in the photo. Remove plastic pin on the right side.

6.32. Front Isolation Foam

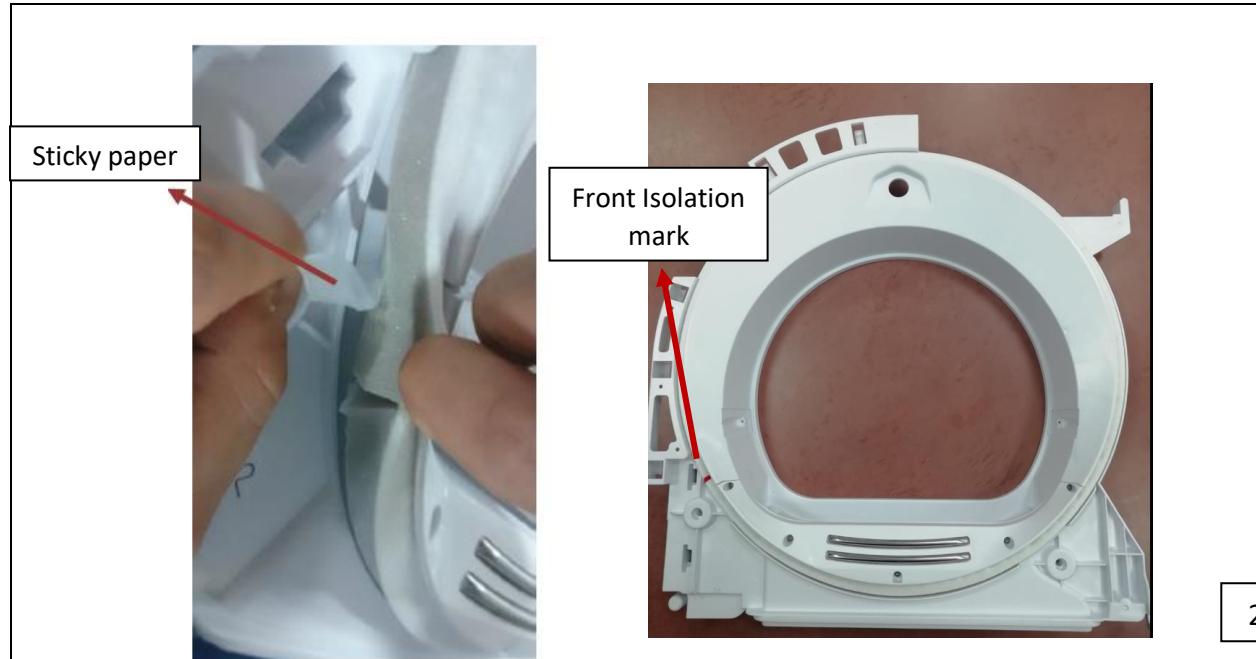

2

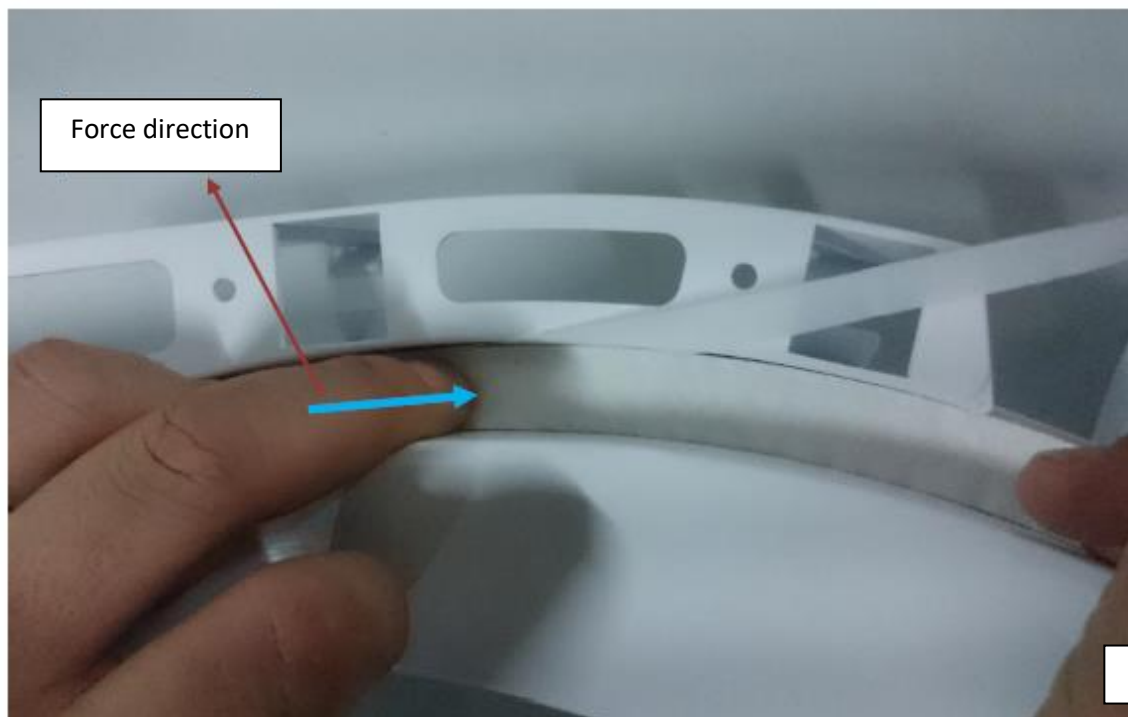

3

1. It is important to install the new felt correctly after it has been removed from the slot at the front shield.
2. Before Sticky paper is opened, front isolation foam should be placed to slot on front shield. Front isolation foam mark should be on left bottom of front shield.
3. Stick the foam on front shield as shown in the photo.
4. Isolation should be centered on slot

6.33. Cable Group

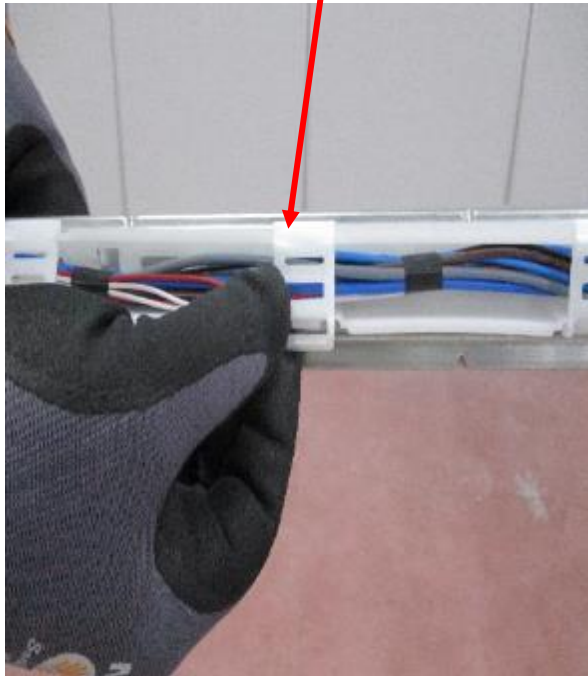
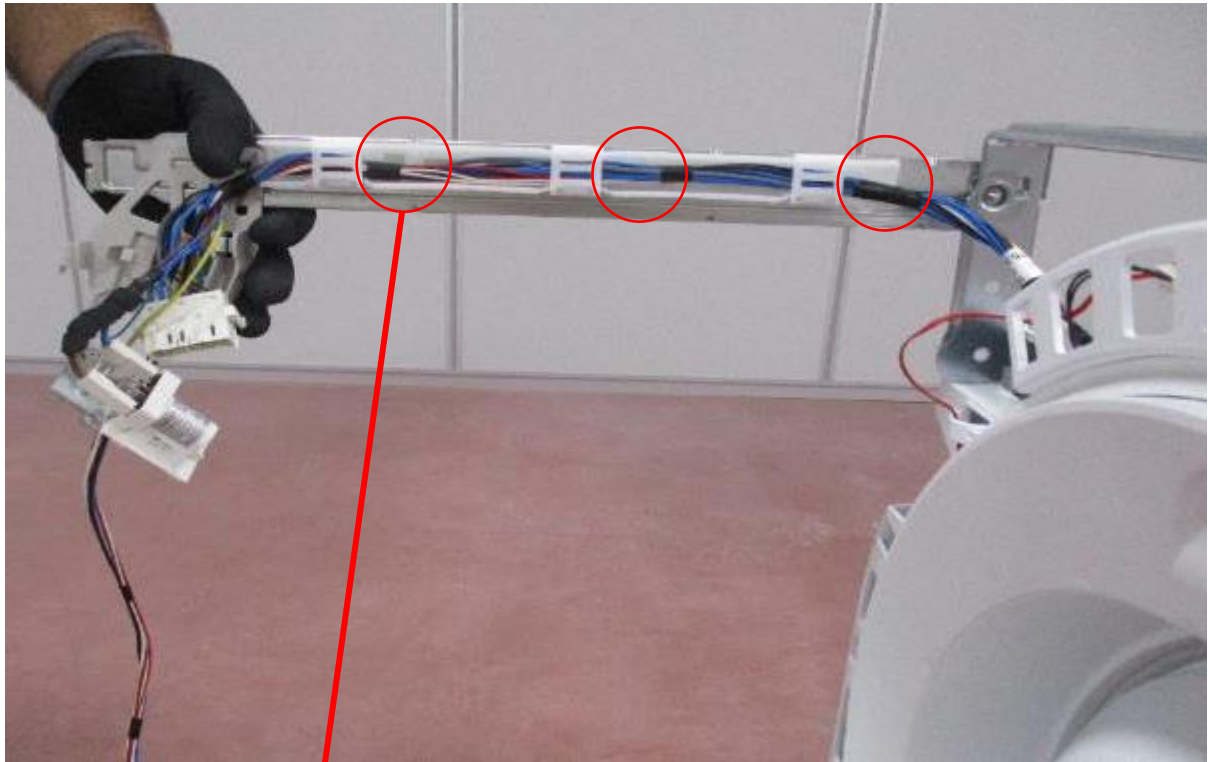

1. Open the cable holder plastic clips on side bracket.
2. Remove cable holder plastic fixing clips as shown in the photo.

6.33. Cable Group

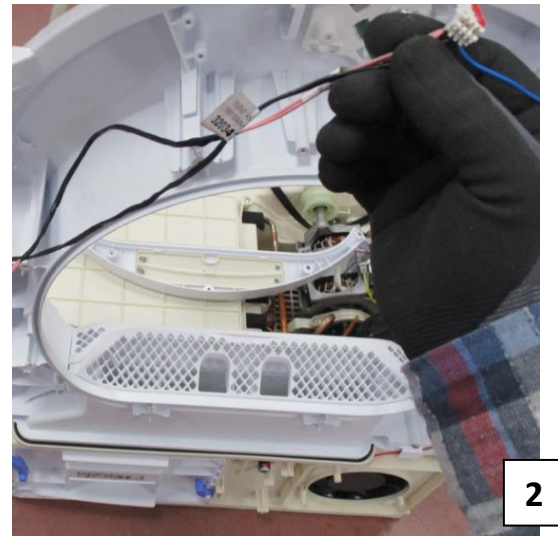
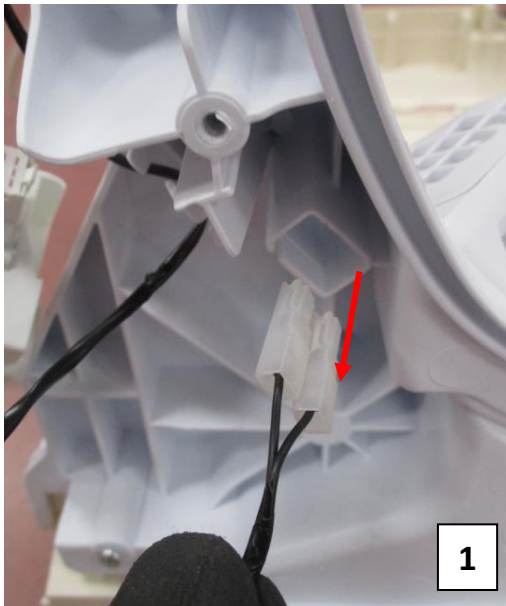

1. Humidity Sensor Cable
2. Door Latch Socket Cable
3. Cable Group of Front Shield

7. COMPONENT SPECIFICATIONS AND MEASUREMENTS

7.1. Motor

The dryer has an asynchronous motor. In the photo on the right, the socket on the motor are shown to be measured by multiple counters. It is driven with triac via the electronic card (to give energy) and relay (for direction control).



Technical Features

Type: single-phase asynchronous motor
 Power: 200 W (Unloaded drum)
 Main windings: $21.5 \pm 7\%$ (20 °C temp.)
 Aux windings: $19.5 \pm 7\%$ (20 °C temp.)

Motor speed : 2750 rpm (Unloaded drum)
 Drum speed : 52 ± 2
 Capacitor value : $11 \mu\text{F} \pm 5\%$

Component Test

- Check whether the motor cable is connected to the motor connector.
- Check the connection of the capacitor cables
- Measure the resistance values and check the capacitor values
- Check whether it is working by connecting via the terminals 1 and 2 (Blue-White) connection
- If it is working, revolution of the drum is measured in unloaded state.

The terminals 1-3 of the motor should be connected with capacitor

Resistance measurement of main winding: Terminal 1 -2 (Blue-White) is measured.

Resistance measurement of aux winding: Terminal 3 -2 (Red-White) is measured.

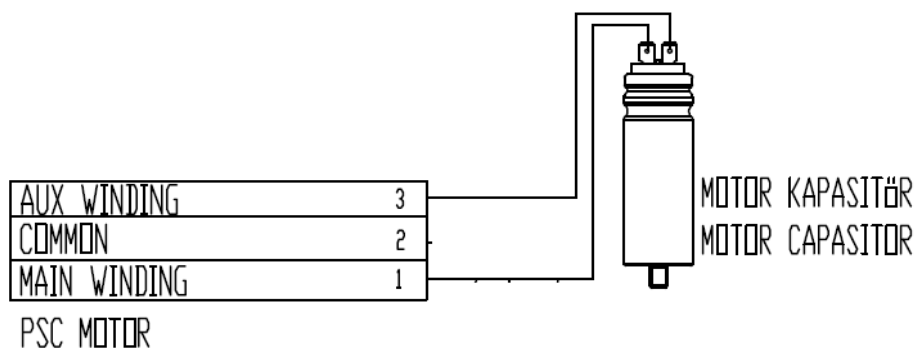

7.1.1. Motor Measurements

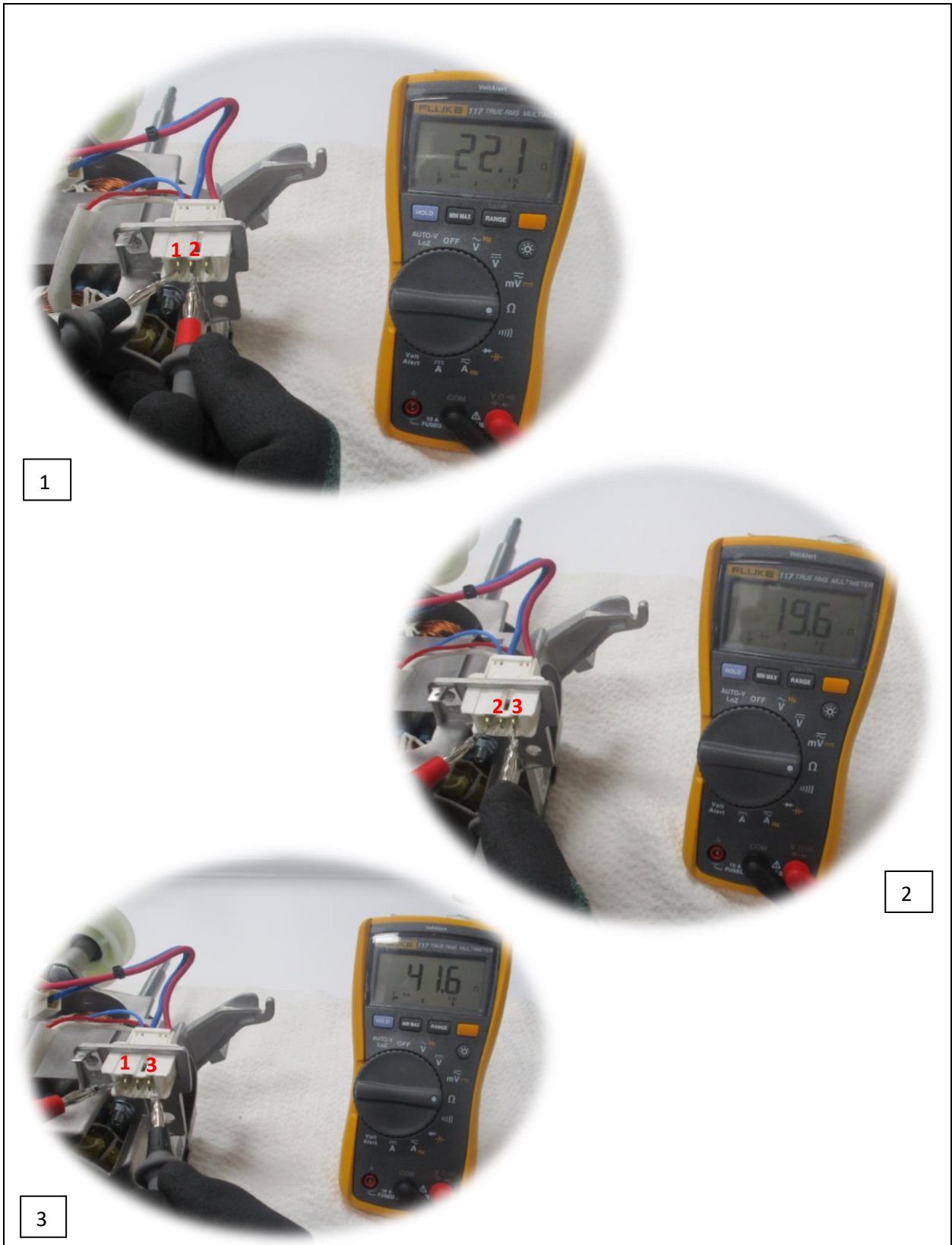

7.2. Pump

In Tumble Dryer models, the pump is used to transport the water that accumulates in the condensation chamber to tank in the drawer area. One triac is measured on the electronic card.



Technical Features

Resistance : 764±10% ohm
Voltage: 220-240 Volt
Frequency: 50 Hz

Input Power : 13W max

Component Test

- Check the connection of the pump connector
- Check the pump resistances
- Check whether pump is working, by feeding externally
- If the pump is working, the water in the tank is unloaded by running the pump Then, Unload 500 ml of water from water tank to pump reservoir and check whether water is pumping.
- While pump is working, if water is not reached into water tank, hoses should be checked.

7.2.1 Pump Measurements

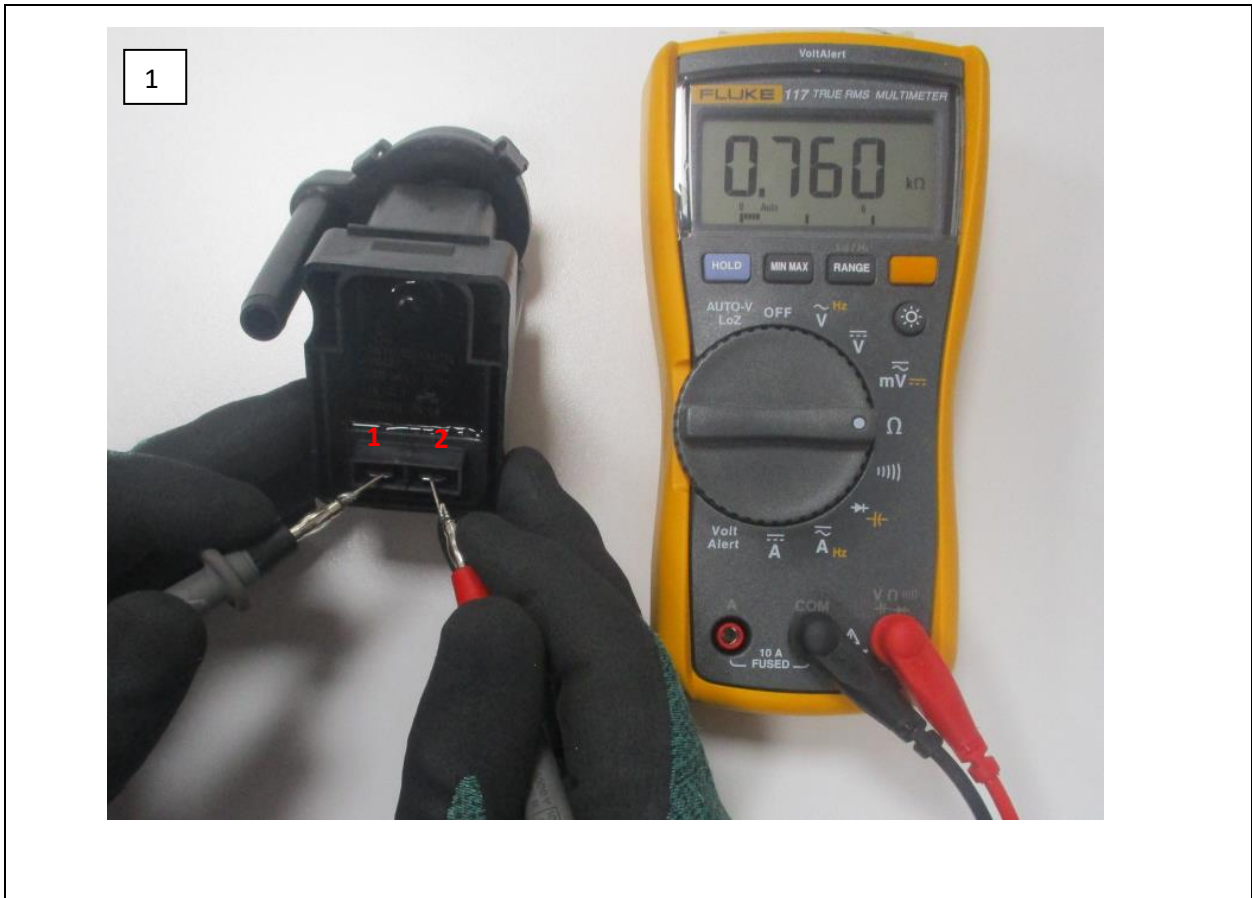

7.3. Electronic Card

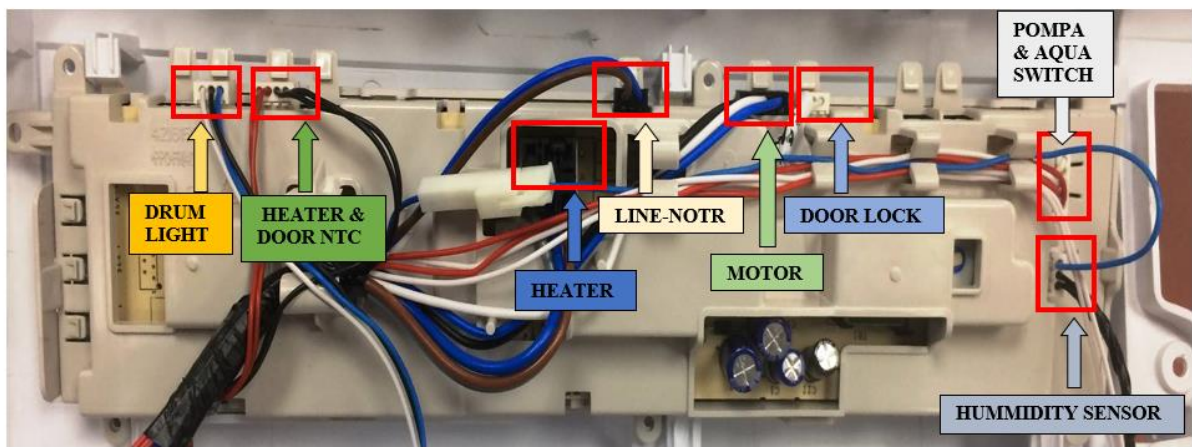
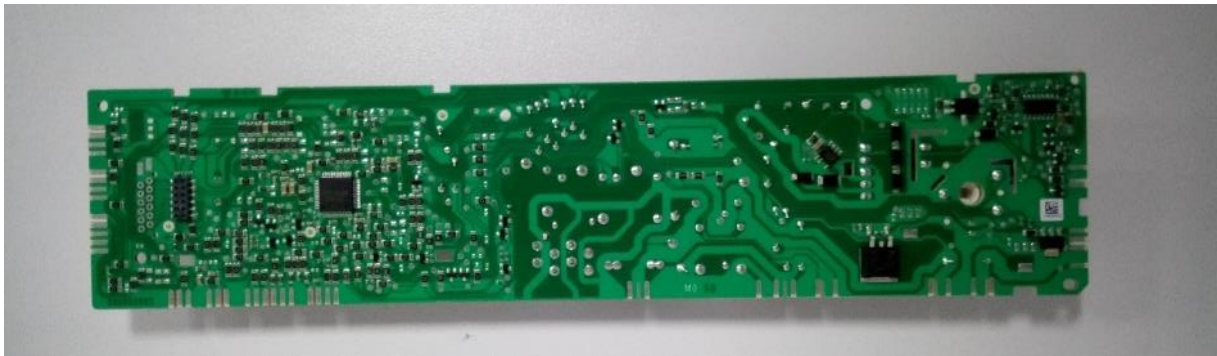

Technical Features

Electronic card is single sided printed circuit board and CEM-1 material

The upper picture shows where the components are inserted.

7.4. Door/Heater NTC Sensor

Two NTC sensors are used. The NTC resistance decreases when the temperature rises. The heater works till the temperature reach required value.



Technical Features

Door NTC Resistance : 12 k Ω (Measured from IDC connected to electronic card) (20 °C temp.)

Heater NTC Resistance : 19.5 k Ω (Measured from IDC connected to electronic card) (20 °C temp.)

Component Test

- Resistance is measured from IDC connected to electronic card
- If the resistance cannot be measured, (from door, 7-pin sockets or heater) check the connector connections of the NTCs
- If there is no problem about connector , check whether there is break in the cables by using multimeter

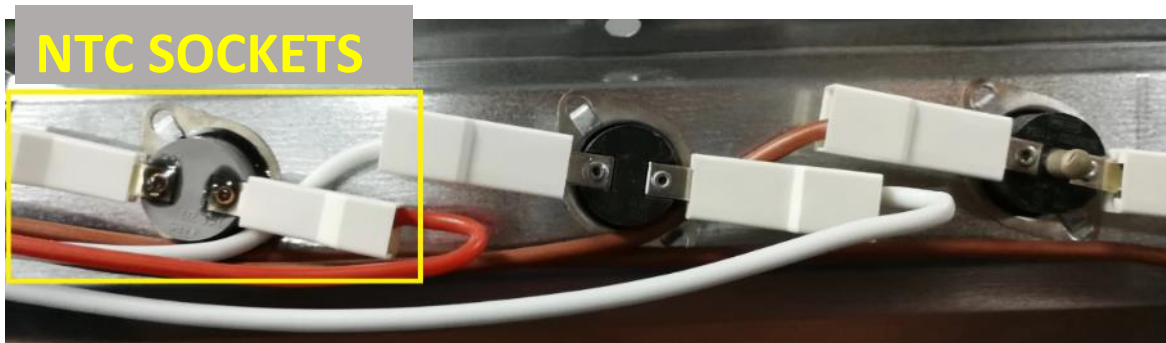

7.4.1. Door NTC Sensor Measurements

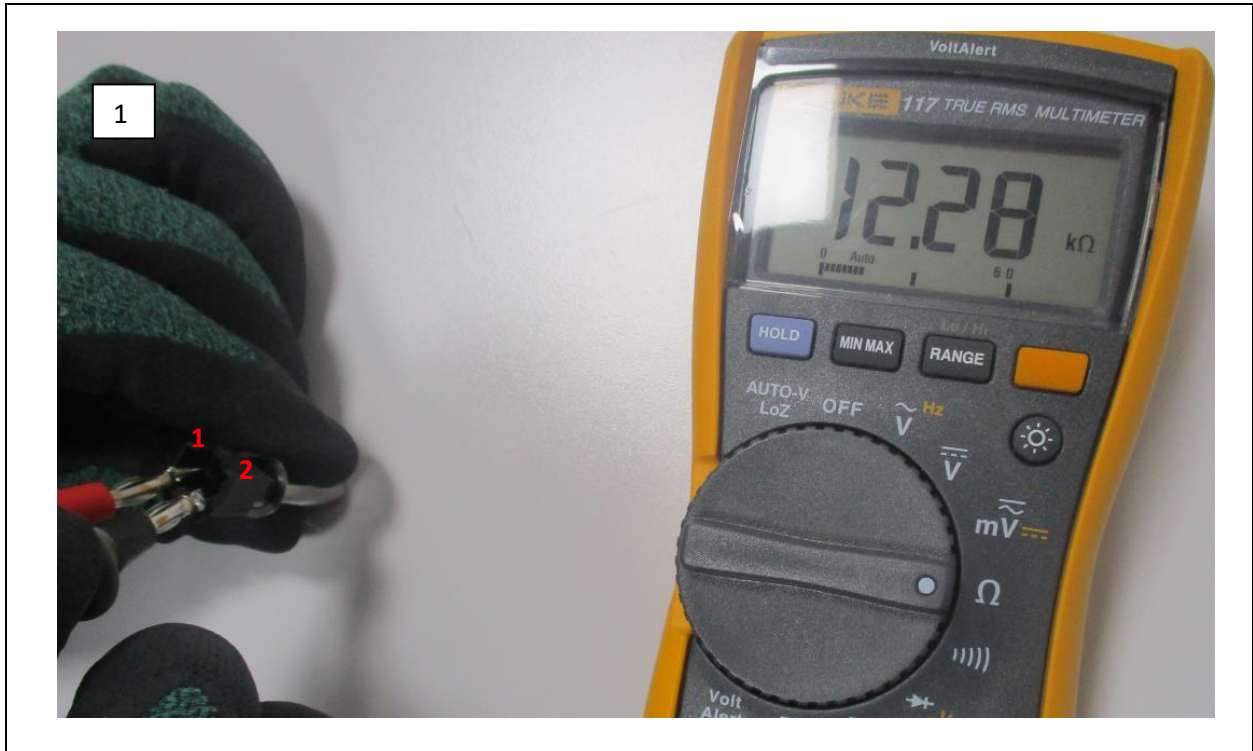

7.4.2. Heater NTC Sensor Measurements

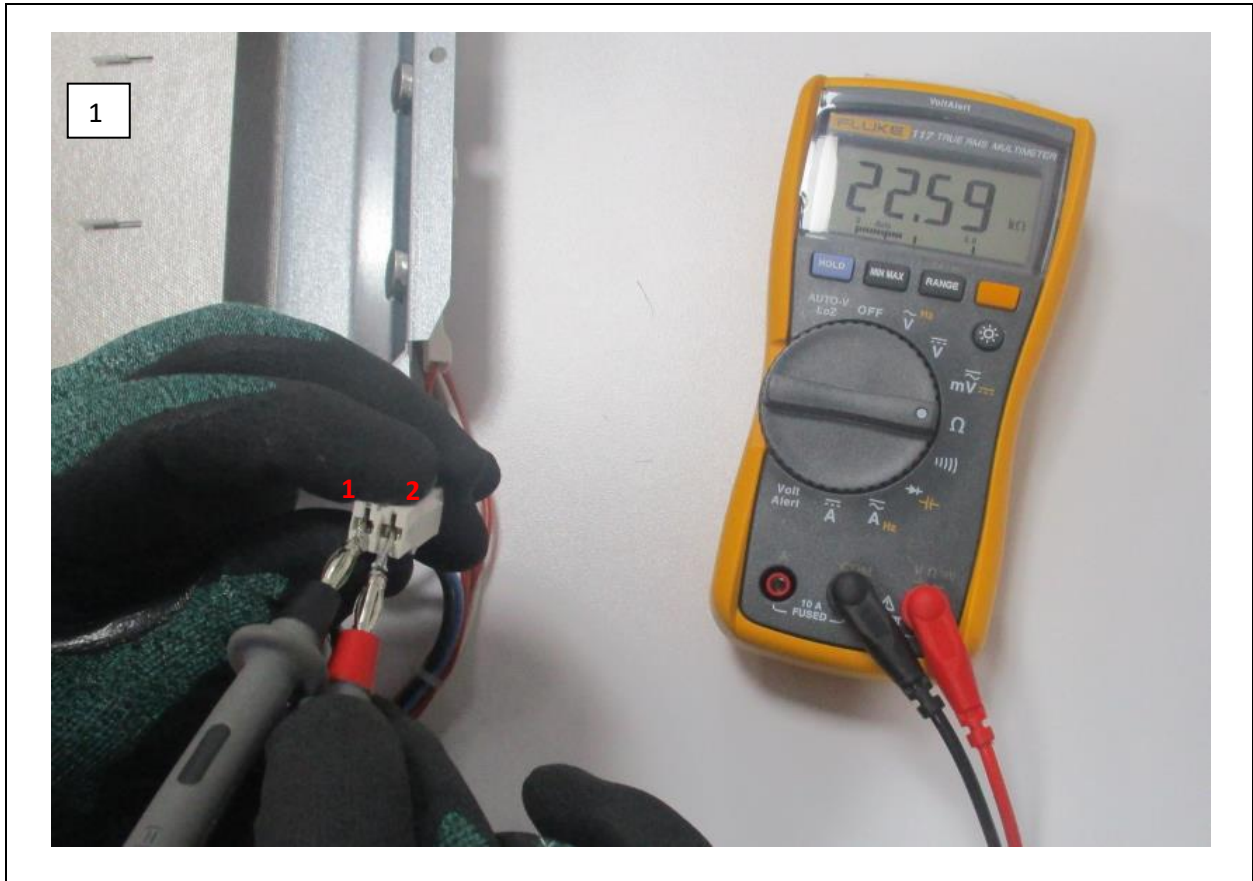

7.5. Heater

Resistance is the component used to increase the temperature of the air in the drum. It consists of two stages (1600+900=2500W). It is controlled by two relays via electronic card.

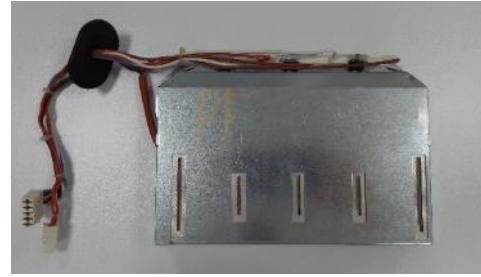

Technical Features

Type : Open spiral heater

Nominal Power and Voltage: 230VAC, 1600+900 W = 2500 W ± %5

Resistance : 1600 W stage 1 (33.44 Ω± %5) – measured from terminal 3 and 6
: 900 W stage 2 (59.45 Ω± %5) – measured from terminal 3 and 7

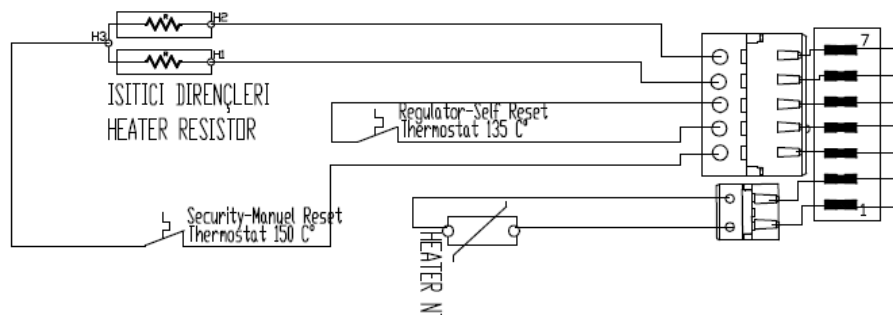

Component Test

- Heater resistances are measured from sockets
- If resistance cannot be measured, check the connection of the heater connectors with 7-pin sockets. Heater connectors must be plugged into 7-pin connectors in accordance with their password. Connections of the manual thermostat and auto thermostat connector on the heater are checked. The thermostat with manual reset is checked whether there is open circuit at the terminals by the multimeter. If it's open circuit, button is up and the heater doesn't work. By pressing the button circuit will be closed, then heater works.



7.5.1. Heater Measurements

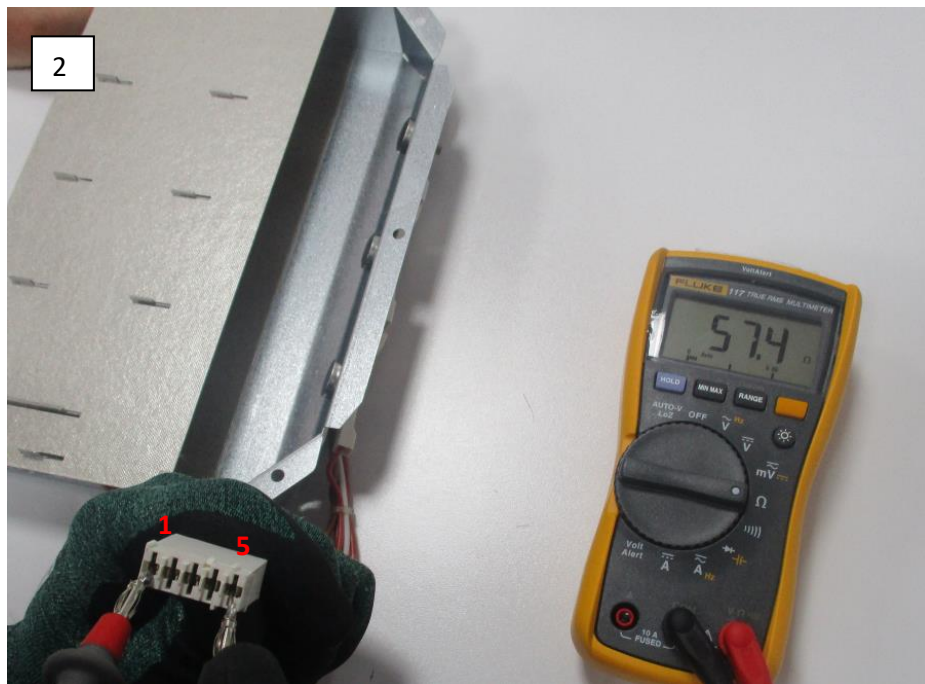

7.6. Door Latch

Door latch (switch) will be at “closed” position when the door is closed.
It’s designed to be opened from inside, in case of any children gets inside the drum



Component Test

- When the door is closed, check whether there is electrical transmission from IDC connected to electronic card (Buzzer mode should be selected on multimeter)
- Check the connection of the component connector

7.6.1 Door Latch Measurements



7.7. Humidity Sensor

The Humidity Sensor measures the amount of dryness of the laundry in the drum.

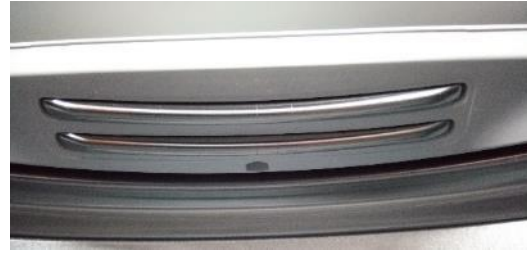

Component Test

- Each humidity sensor plate is checked whether there is electrical transmission from IDC connected to electronic card. (Buzzer mode should be selected on multimeter)
- Check the connection of the component connector

7.7.1 Humidity Sensor Measurements



7.8. Condenser

In the condenser, there are crossed channels that allow to flow the hot and cold fluid. Thus, They allow the hot air reach to the condenser and leave its humidity by cooling.



7.9. Drumlight

Drumlight illuminates inside of the drum



Component Test

Check whether there is electrical transmission from IDC connected to electronic card.

8. TROUBLESHOOTING

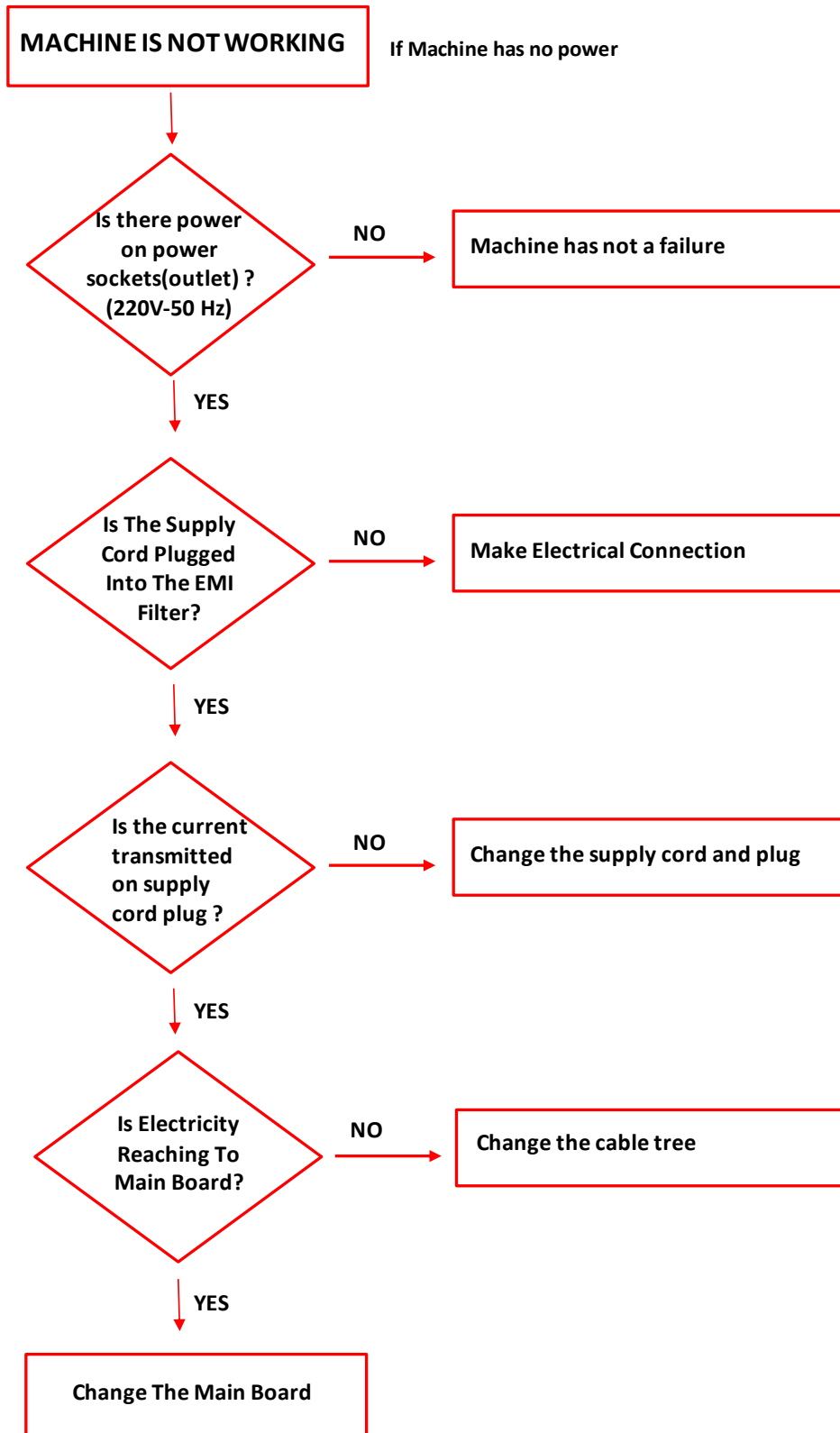

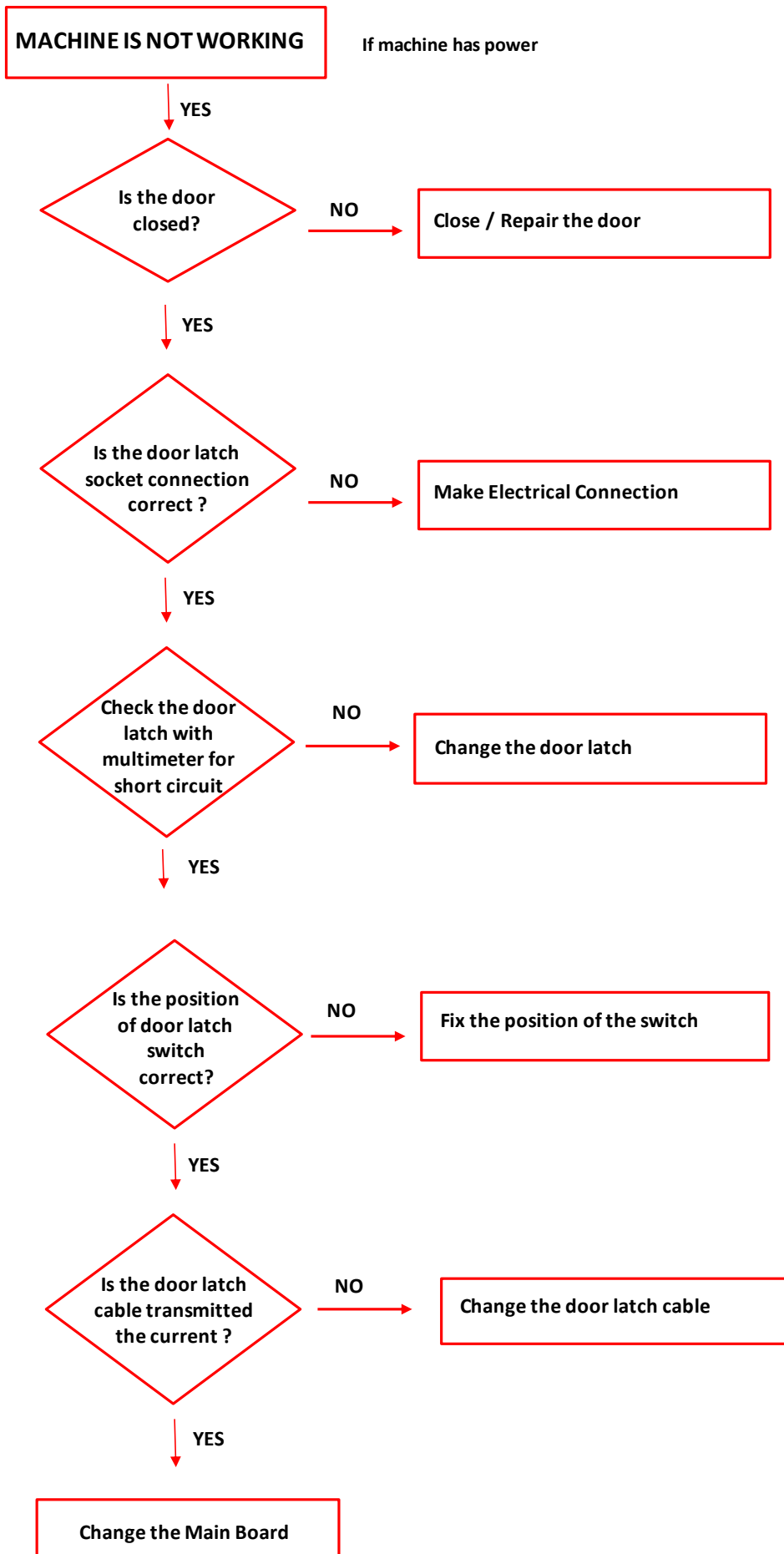

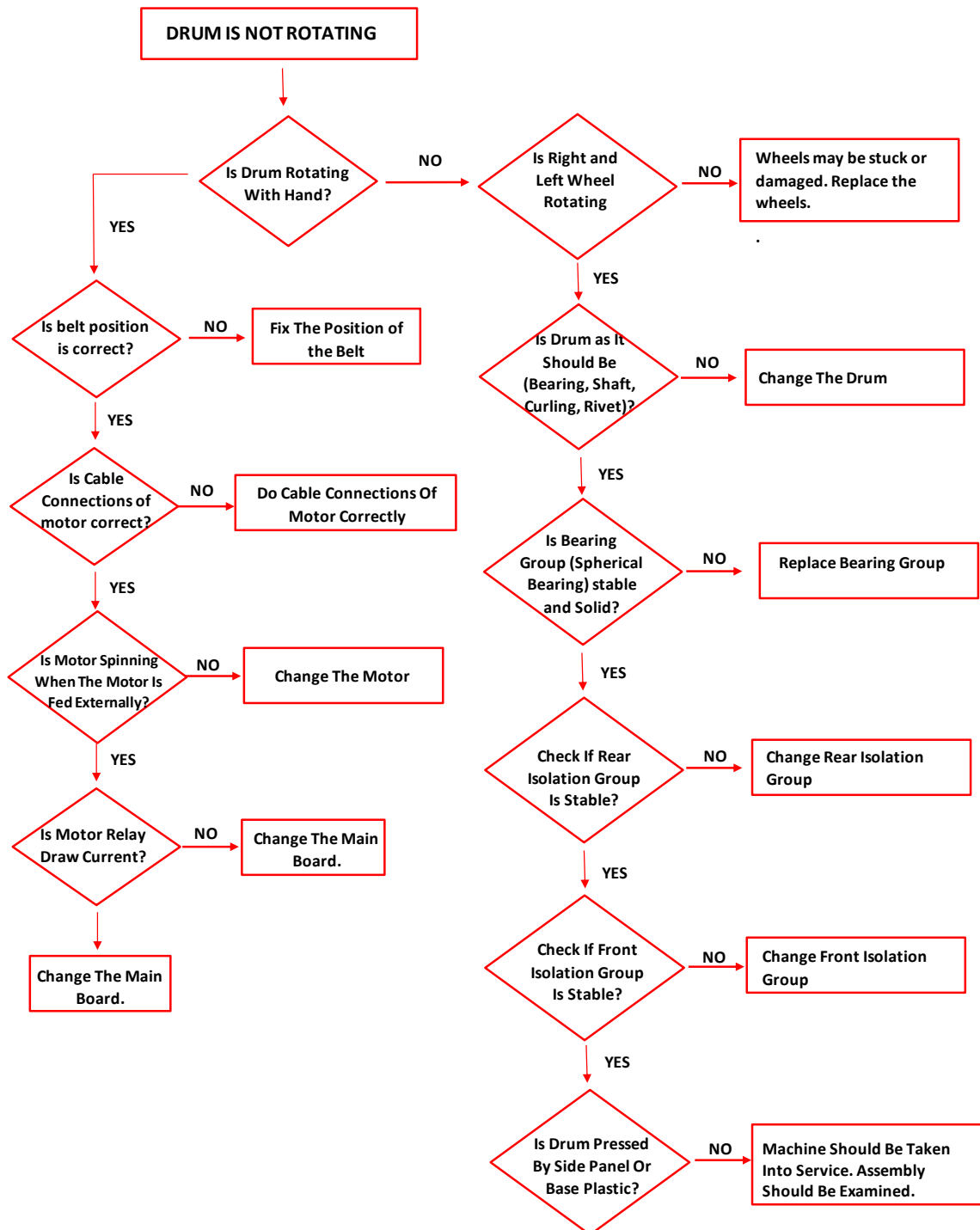

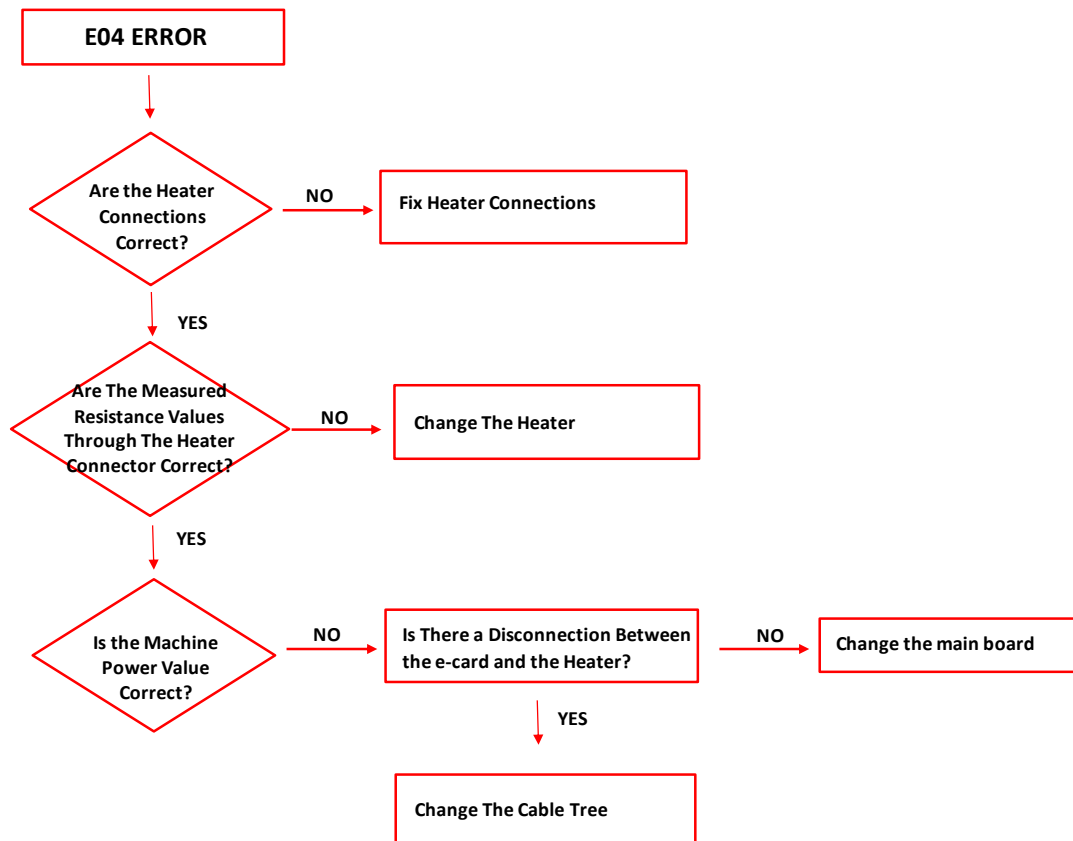
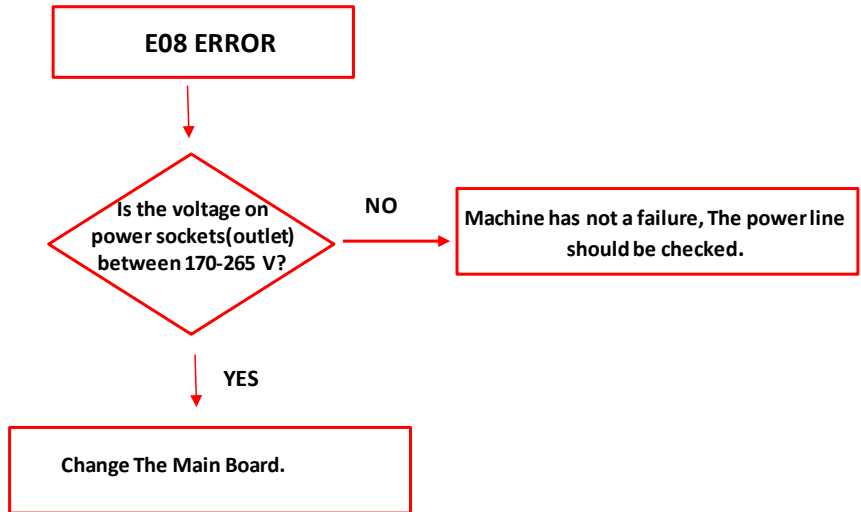



F4 B PANEL SERVICE MANUAL

CUSTOMER SUPPORT

