



---

# SECHE LINGE CODES ERREURS

**BANDEAU HP F4 U - Inverter**





## 4. CONTROL PANEL AND PROGRAM SELECTION TABLE

### 4.1. Control Panel



### Display Symbols

Water tank warning indicator	
Lint filter cleaning warning indicator	
Heat exchanger cleaning warning indicator	

### 4.2. Program List

KNOB POSITION	PROGRAM
1	Cotton Extra Dry
2	Cotton Cupboard Dry
3	Cotton Iron Dry
4	Synthetics Cupboard Dry
5	Synthetics Iron Dry
6	Delicate
7	Time Drying*
8	Baby Care
9	Duvet
10	Sport
11	Mix
12	Wool Refresh
13	Refresh
14	Jet Dry 45'
15	Shirts 30'
16	OFF



\*\*\*The machine has humidity sensor that detects whether the laundry dry or not. At the programs that work with humidity sensor laundry does not dry in fixed time. Duration is constantly updates according to humidity data taking from laundry.

\*\*\***Time Drying Program:** Humidity sensor is deactivated. The program ends when the time is up, without checking the humidity of the laundry.

\*\*\***Jet Dry 45' / Shirts 30' :** Humidity sensor is activated. The program time may extend, if the customer use different laundry according to the load in the program description.

Jet Dry 45' : 2 kg of cotton shirts spun at a high speed in the washing machine are dried in 45 minutes.

Shirts 30' : 2 to 3 shirts are ready for to be ironed in 30 minutes.

\*\*\***Delicate:** Delicate fabrics are dried for a longer time at a low temperature.

\*\*\***Wool Refresh / Refresh:** Compressor is deactivated. The air is not heated.

### 4.3. Children's Safety



There is a child lock option to avoid changes in the program flow pressed during the program.

There is 2 panels version which is Delicate or Anti Crease .To activate child lock;

If It is Anti Crease panel, press and hold "Delay Timer" and " Anti-Crease " keys simultaneously for 3 seconds.

If It is Delicate panel, press and hold "Delay Timer" and "Delicate" keys simultaneously for 3 seconds

When the child lock is active, all keys will be deactivated. Child lock will be deactivated automatically at the end of the program. When activating/deactivating the child lock, the leds of the "Anti-Crease" and "Delicate Drying" options will flash and an audible warning will be heard.

## 5. FAILURE MODES AND SERVICE AUTOTEST

\*\*\***Service auto test must be run for every service call.**



	<b>BANDEAU HP F4 U</b>
	<b>Inverter</b>

### 5.1. Failure Modes and Warning Leds

F4/F4T HEAT PUMP MODEL ERROR CODES	
ERROR CODE	REASON
E00	F4 Touch UI board doesn't receive communication from mainboard
E03 / 	Aquaswitch connector is disconnected
E04	Compressor connector is disconnected
E05	Compressor NTC connector is disconnected
E06	Door NTC connector is disconnected
E07	Motor connector is disconnected, motor is locked
E08	Voltage fluctuation

#### **Notes For Service autotest:**

\*Service can not pass the current step before completing the minimum duration

\*When minimum duration for each step (5 sec) is completed, filter led makes slow blink to indicate that service can pass the next step

\*For error codes, leds must make fast blink

	<b>BANDEAU HP F4 U</b>
	<b>Inverter</b>

## 5.2. Service Autotest Steps

STEPS	Control		Possible Errors
<b>The Routine to Enter Servis Autotest</b>	While pushing <b>SW2</b> button for 5 sec, position knob to Program 1. Then press Start/Pause button. Machine enters to service autotest. For F4: When machine enters service autotest, SAU becomes fix on for 2 sec and all warning leds make fast blink for 2 sec and then becomes fix off .Machine shows the last error saved by machine. If there is no error, "---" visualise on the display When knob positioned to program 2, control steps starts.		
Step 2 (Knob Position 2)	Dryer check Aquaswitch, if aquaswitch ON go to next step (pump activation), if aquaswitch OFF give water tank full error	E03	*Aquaswitch connector is taken out *Aquaswitch connector is short circuit *Styrofoam is borken or not
Step 3 (Knob Position 3)	Pump is on	-	Service must pour water to pump reservoir and check whether water is pumped to tank. If water is not pumped to water tank; *Pump connector is taken out
Step 4 (Knob Position 4)	Motor CCW (Tumble CW)-Motor stops	-	Service must check whether tumble is moving to CW. If not; *Motor connector is taken out *Motor might be locked *Motor belt might be dislocated
Step 5 (Knob Position 5)	Motor CW (Tumble CCW) -Motor stops	-	Service must check whether tumble is moving to CCW *If tumble is moving to CW again, then motor relay short circuit CCW
Step 6 (Knob Position 6)	Check Compressor NTC if heater NTC T=255	E05	*Compressor NTC connector is taken out or short circuit
Step 7 (Knob Position 7)	Check Door NTC if heater NTC T=255	E06	*Door NTC connector is taken out or short circuit
Step 8 (Knob Position 8)	Compressor OFF- Motor CCW (Tumble CW) OFF- Cooling fan ON	-	Service must check power of at the home voltage and fan will be controlled manually by technical service.
Step 9 (Knob Position 9)	Compressor ON- Motor CCW (Tumble CW) Motor OFF	-	Service must check power of at the home voltage.
Step 10 (Knob Position 10)  <b>Remove the last error (Knob position 1)</b>	Check conductivity sensor when door is opened and motor is off  DEL is visualized on display and make fast blink for 2 sec.	E01  DEL	Service puts his hand on the humidity sensor plates and software checks sensor data *If sensor data=0, humidity sensor connector is taken out  When the knop positioned to program 1, service will pust the both SW2 and SW4 (child lock mode).

	<b>BANDEAU HP F4 U</b>
	<b>Inverter</b>

## 7. 7. COMPONENT SPECIFICATIONS AND MEASUREMENTS

### 7.1. Motor

The dryer has an BLDC motor. In the photo on the right, the socket on the motor are shown to be measured by multiple counters. It is driven with the electronic card (Driver).

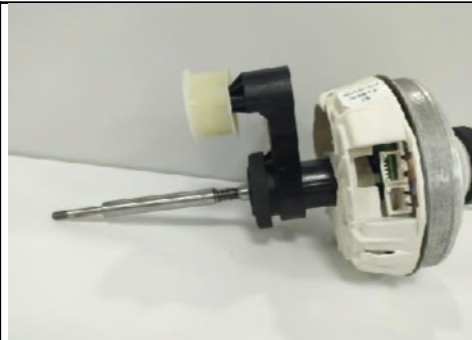

#### Technical Features

Type: BLDC motor  
 Power: 18 W (Unloaded drum)  
 Windings: 7,9±8% (20 °C temp.)

Motor speed : 2700 rpm (Unloaded drum)  
 Drum speed : 51 ± 2

#### Component Test

- Check whether the motor cable is connected to the motor connector.
- Check the connection of the capacitor cables
- Measure the resistance values and check the capacitor values
- Check whether it is working by connecting via the terminals 1 and 2 (Blue-White) connection
- If it is working, revolution of the drum is measured in unloaded state.

Resistance measurement of main winding1: Terminal 1 -2 is measured.

Resistance measurement of main winding2: Terminal 1 -3 is measured.

Resistance measurement of main winding3: Terminal 2 -3 is measured.

CONNECTION DIAGRAM

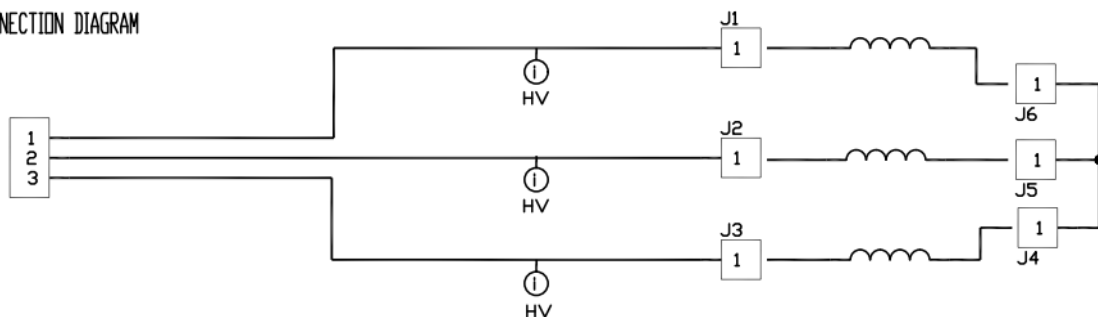

J = FASTON CONNECTION ON THE BOBBIN HOUSING

7.1.1. Motor Measurements



	<b>BANDEAU HP F4 U</b>	
	<b>Inverter</b>	

## 7.2. Pump

<p>In Tumble Dryer models, the pump is used to transport the water that accumulates in the condensation chamber to tank in the drawer area. One triac is measured on the electronic card.</p>	
<b>Technical Features</b>	
<p>Resistance : 764±10% ohm Voltage: 220-240 Volt Frequency: 50 Hz</p>	<p>Input Power : 13W max</p>
<b>Component Test</b>	
<ul style="list-style-type: none"> <li>• Check the connection of the pump connector</li> <li>• Check the pump resistances</li> <li>• Check whether pump is working, by feeding externally</li> <li>• If the pump is working, the water in the tank is unloaded by running the pump Then, Unload 500 ml of water from water tank to pump reservoir and check whether water is pumping.</li> <li>• While pump is working, if water is not reached into water tank, hoses should be checked.</li> </ul>	

**7.2.1 Pump Measurements**



### 7.3. Electronic Card

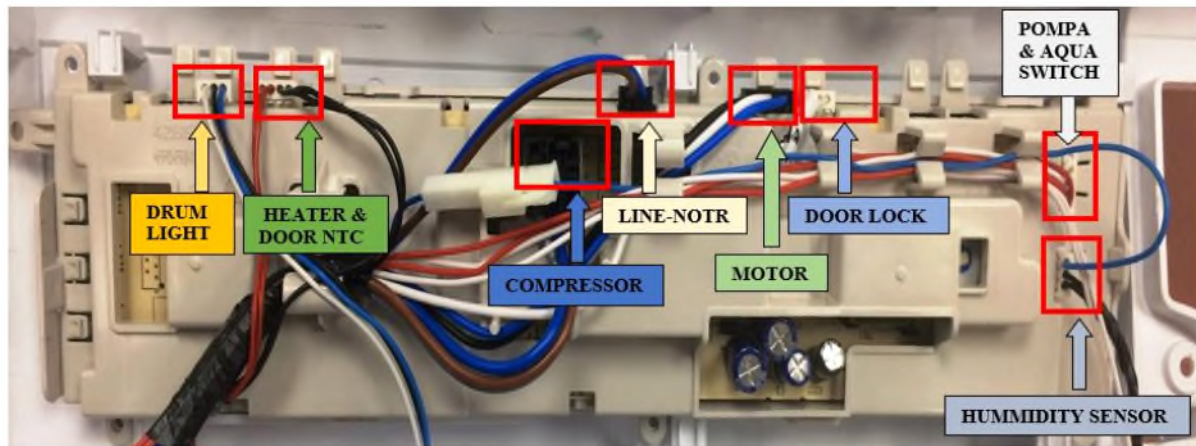
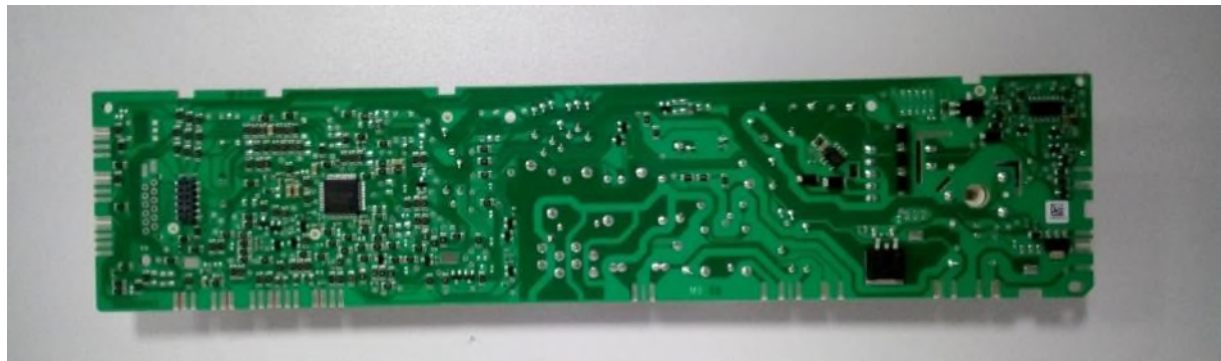

#### Technical Features

Electronic card is single sided printed circuit board and CEM-1 material

The upper picture shows where the components sockets are inserted.

### 7.4. Door/Compressor NTC Sensor

Two NTC sensors are used. The NTC resistance decreases when the temperature rises.



#### Technical Features

Door NTC Resistance : 12 k $\Omega$  (Measured from IDC connected to electronic card )

Compressor NTC Resistance : 12 k $\Omega$  (Measured from IDC connected to electronic card )

#### Component Test

- Resistance is measured from IDC connected to electronic card

**7.4.1. Door NTC Sensor Measurements**

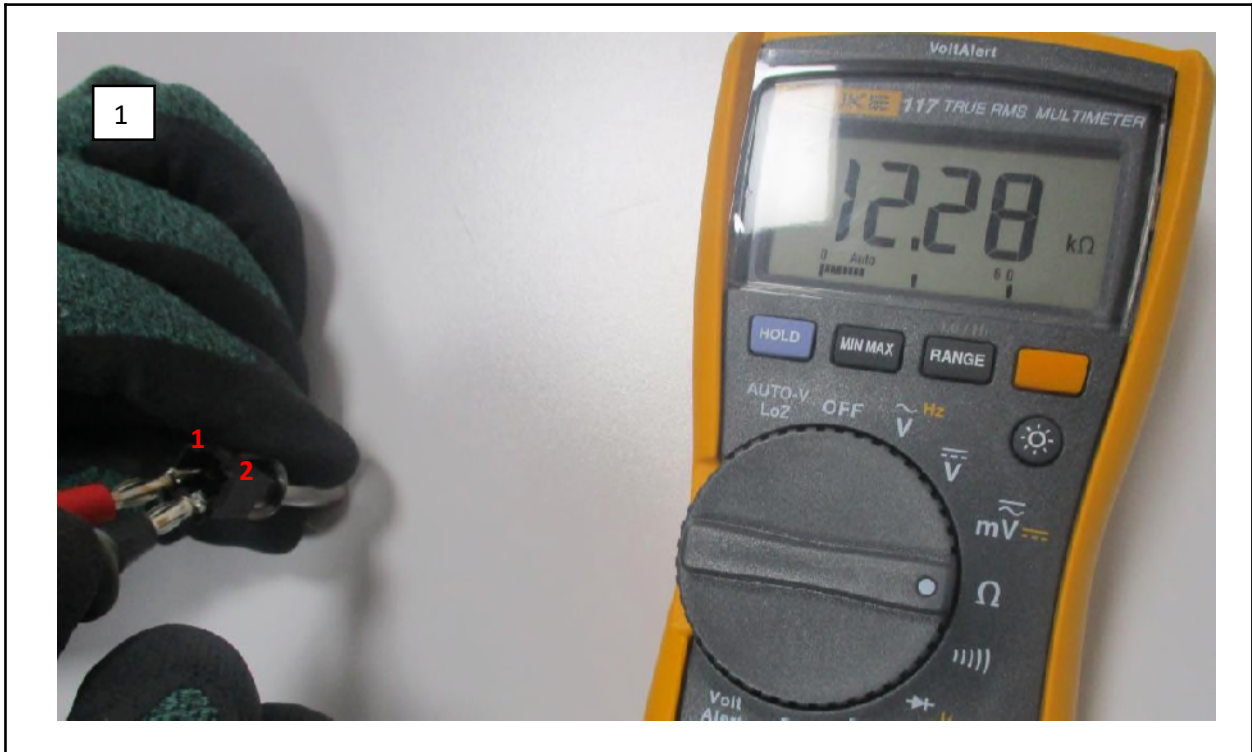

**7.5. Compressor**

The dryer has an compressor with an asynchronous motor. In the photo on the right, the terminal on the compressor are shown to be measured by multiple counters. It is driven with relay via the electronic card (to give energy) and relay drive the compressor only one direction.



**Technical Features**

Type: single-phase asynchronous motor  
 Input Power: 430 W (Unloaded drum)  
 Main windings: 9.3±7% (25 °C temp.)

Aux windings:  $8.75 \pm 7\%$  (25 °C temp.)

Motor speed : 2928 rpm (Unloaded)

Gas Type: R290

Capacitor value :  $20 \mu\text{F} \pm 5\%$

Compressor Capacity:  $6.8 \text{ cm}^3/\text{rev}$

#### Component Test

- Check whether the compressor cable is connected to the compressor terminal.
- Check the connection of the capacitor cables
- Measure the resistance values and check the capacitor values
- Check whether it is working by connecting via the terminals S,R and C connection
- If it is working, start the machine and check the drum temperature.

The terminals S and R of the motor should be connected with capacitor.

Resistance measurement of main winding: Terminal C-R is measured.

Resistance measurement of aux winding: Terminal C-S is measured.

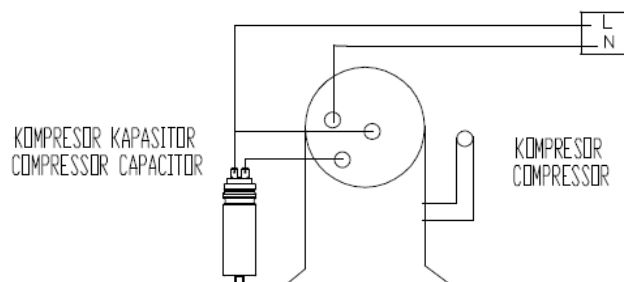

7.5.1. Compressor Measurements

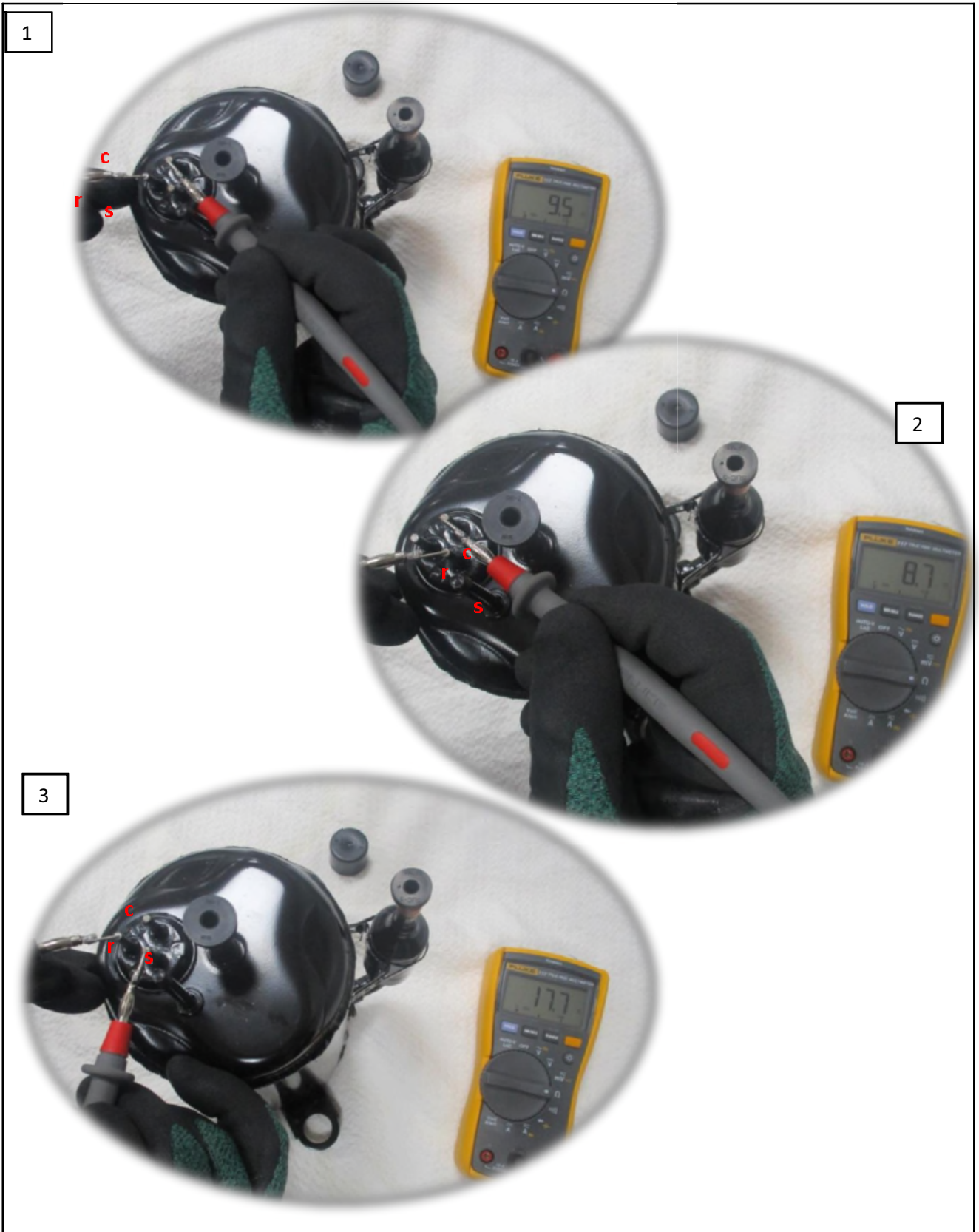

### 7.6. Door Latch

Door latch locks when the door is closed. It's designed to be opened from inside, in case of children are in the drum



#### Component Test

- When the door is closed, check whether there is electrical transmission from IDC connected to electronic card
- Check the connection of the component connector

#### 7.6.1 Door Latch Measurements



### 7.7. Humidity Sensor

The Humidity Sensor measures the amount of dryness of the laundry in the drum.

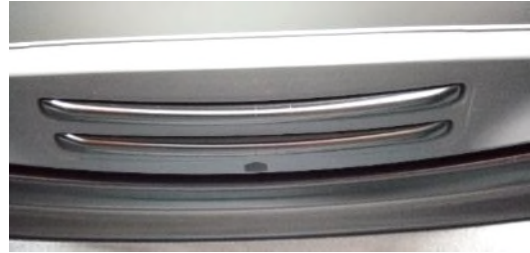

#### Component Test

- Each humidity sensor plate is checked whether there is electrical transmission from IDC connected to electronic card.
- Check the connection of the component connector

#### 7.7.1 Humidity Sensor Measurements



### 7.8. Cooling Fan

The dryer has an cooling fan with an asynchronous motor. In the photo on the right, the terminal on the compressor are shown to be measured by multiple counters. It is driven with triac via the electronic card (to give energy)



#### Technical Features

Type: single-phase AC fan

Power: 28 W

Main windings: 600±7%

Motor speed : 2600/3000 ±10%

#### Component Test

- Check whether the cooling fan cable is connected to the fan terminal.
- Measure the resistance values

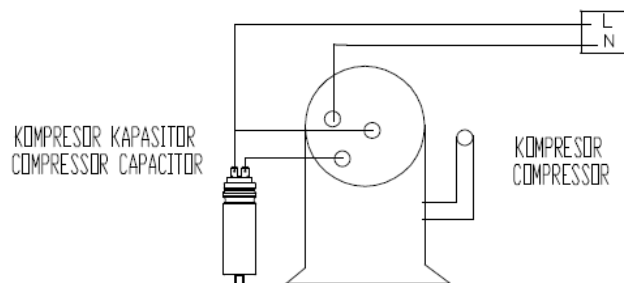

**7.8.1. Cooling Fan Measurements**



**7.9. Drumlight**

Drumlight lights inside of the drum



**Component Test**

Check whether there is electrical transmission from IDC connected to electronic card.

**8. TROUBLESHOOTING**

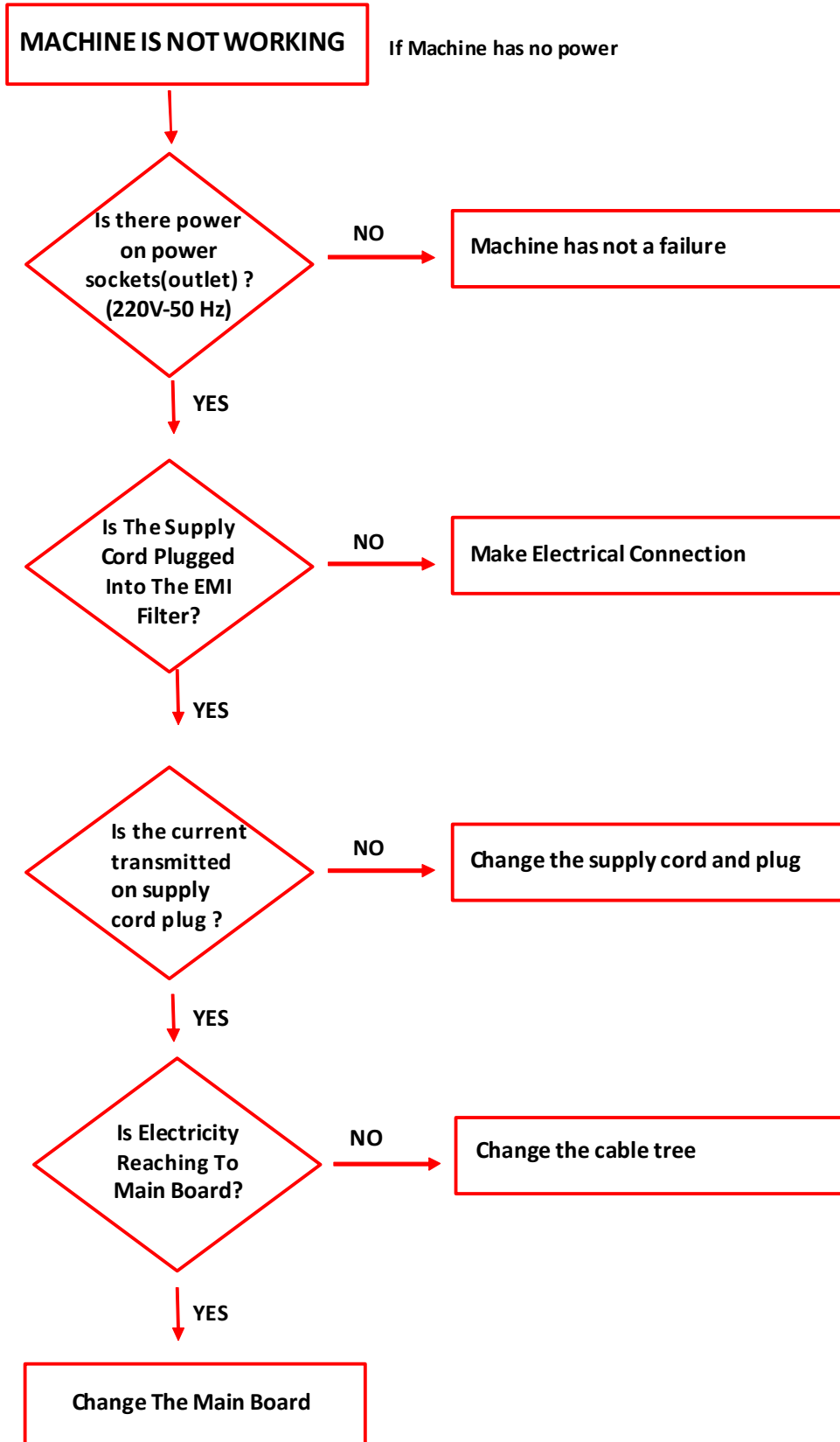



# BANDEAU HP F4 U Inverter

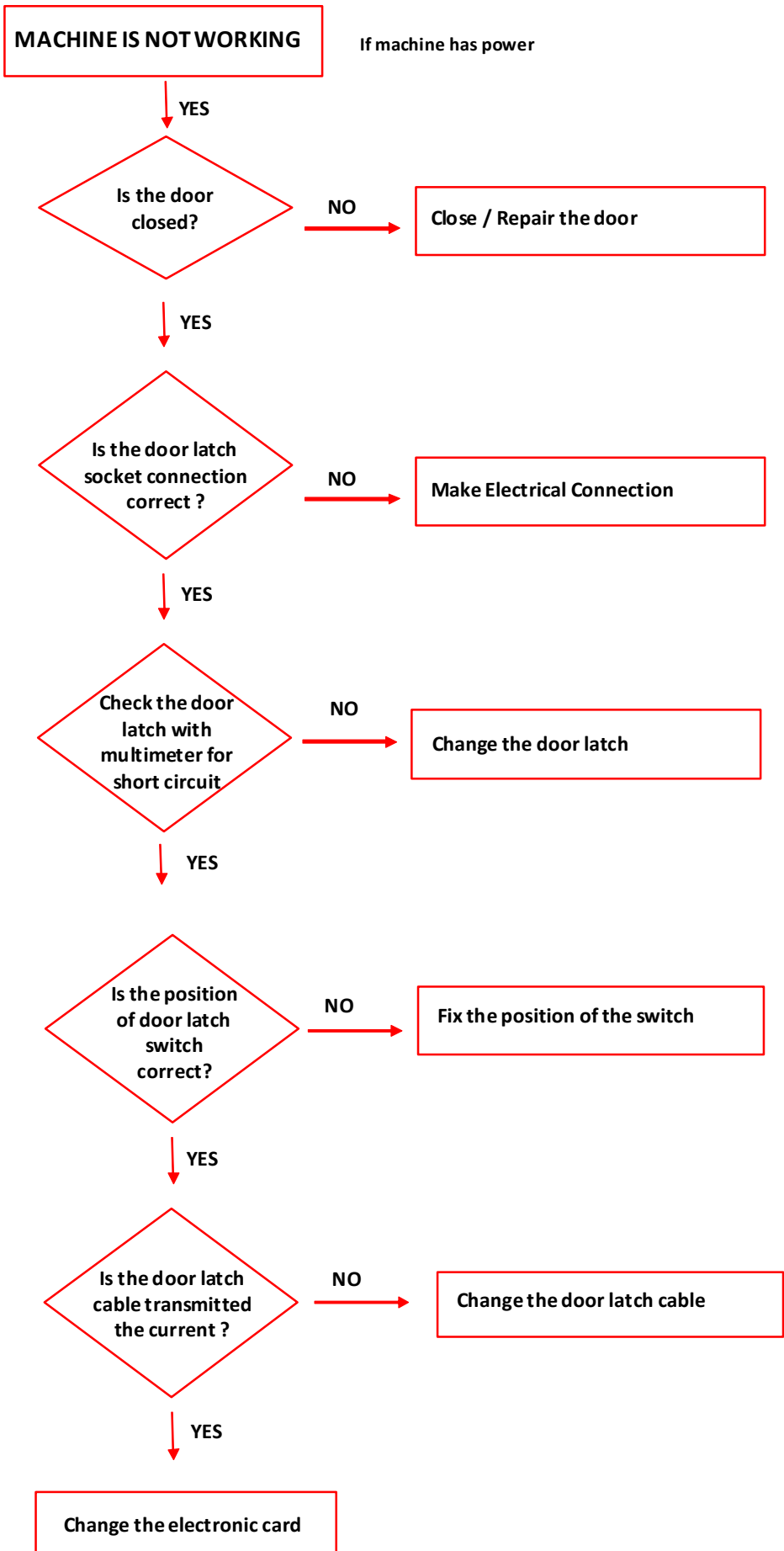
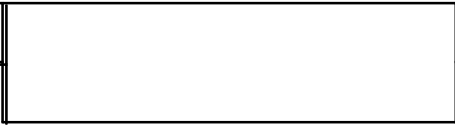

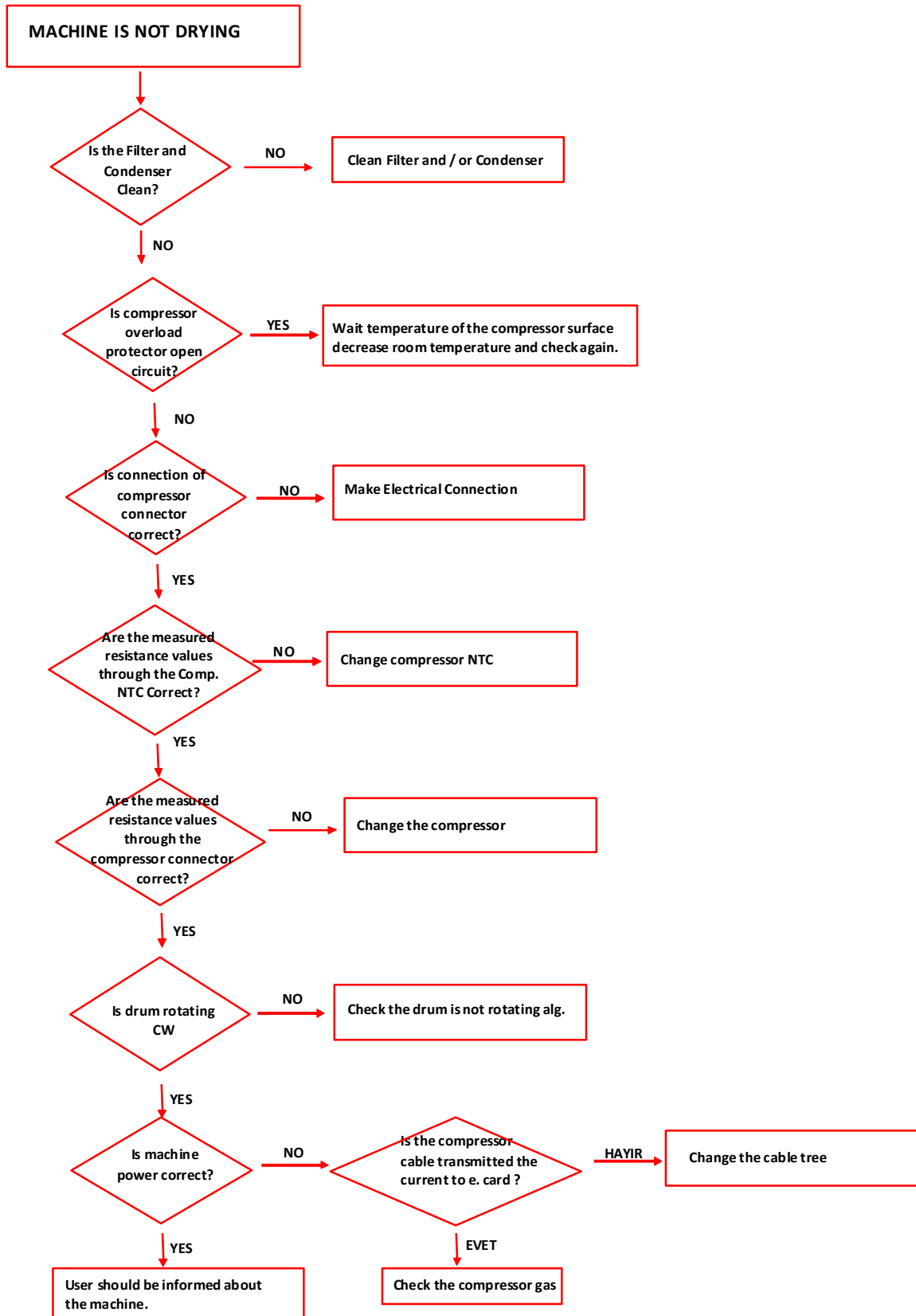

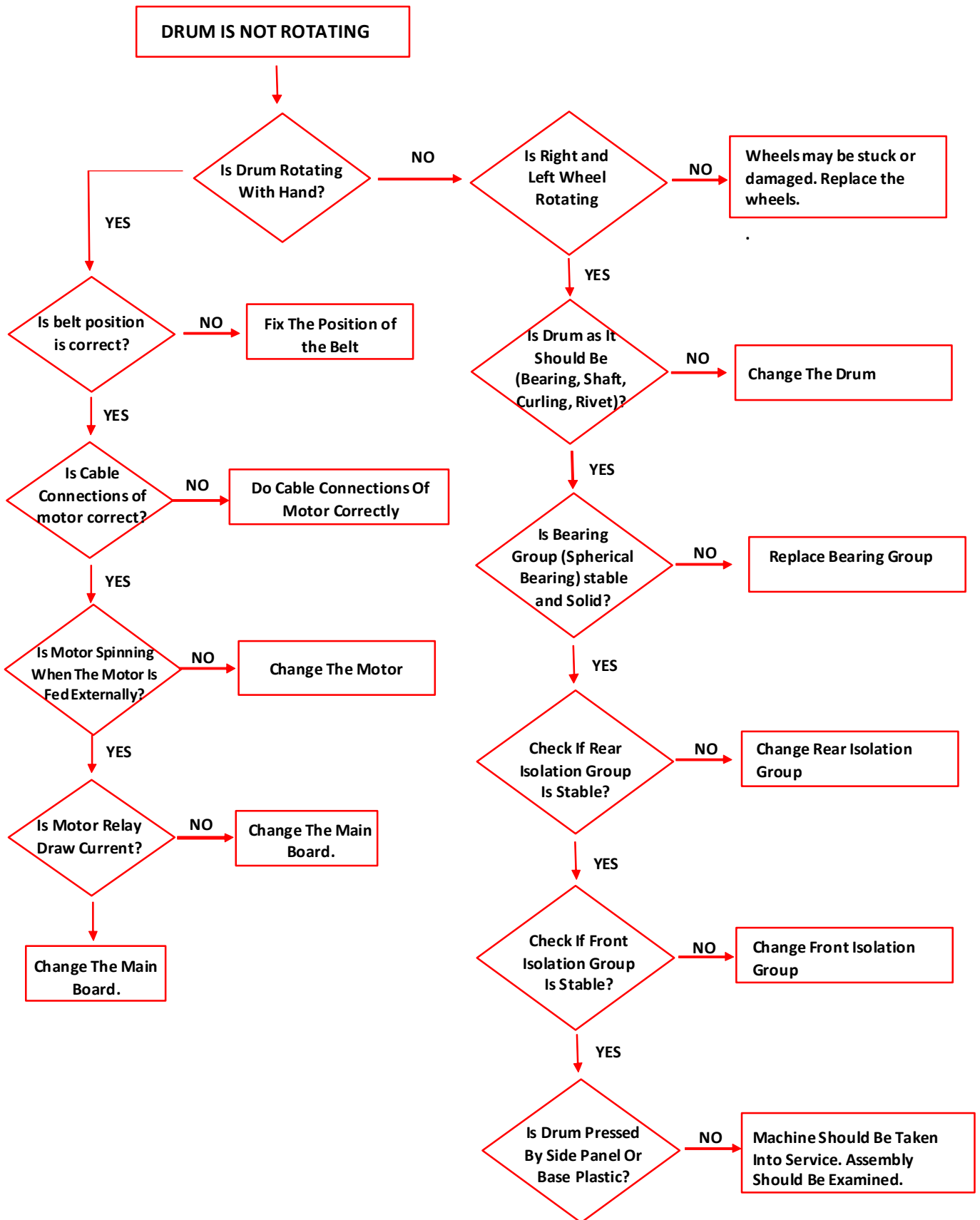

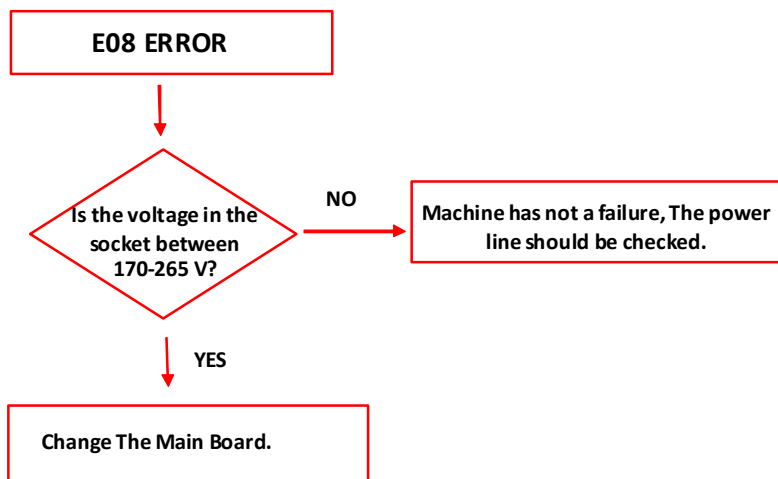
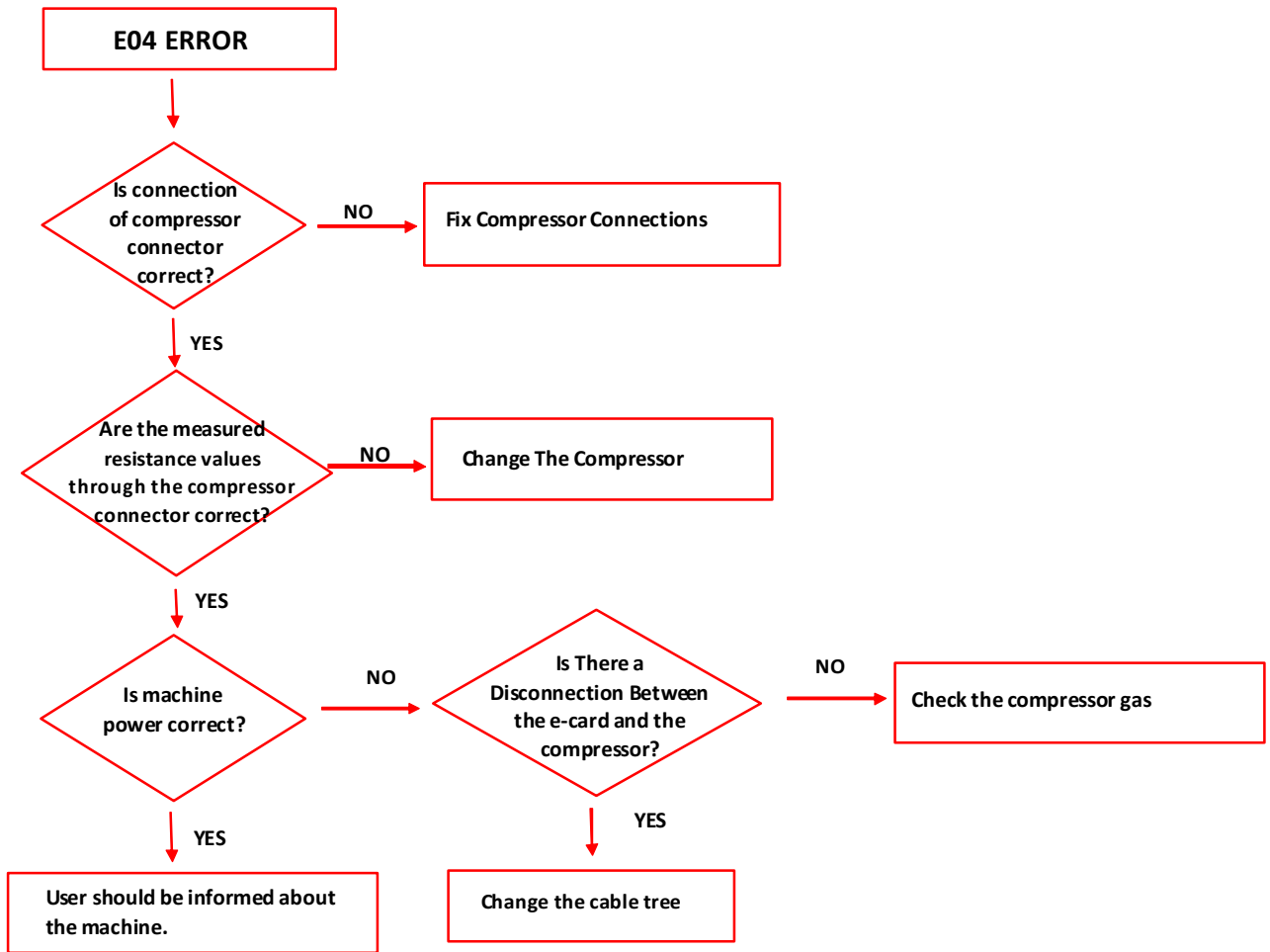



# BANDEAU HP F4 U Inverter

