

SECHE LINGE MANUEL DE SERVICE

BANDEAU T3 Pompe à chaleur



CONTENTS

1. OVERVIEW AND WORKING PRINCIPLE	4
1.2. Working Principle:	4
2. TECHNICAL SPECIFICATIONS.....	5
3. INSTALLATION	5
3.1. Issues that should be informed to customer	5
4. CONTROL PANEL AND PROGRAM SELECTION TABLE	6
4.1. Control Panel	6
4.2. Program List	7
4.3. Children’s Safety.....	8
5. FAILURE MODES AND SERVICE AUTOTEST	8
5.1. Failure Modes and Warning Leds.....	9
5.2. Service Autotest Steps.....	Hata! Yer işareti tanımlanmamış.
6. DISASSEMBLY.....	10
6.1. Top Plate.....	12
6.2. Control Panel	13
6.3. Electronic Card	15
6.4. UI Card	16
6.5. Side Panel	17
6.6. Supply Cable	19
6.7. Emi Filter.....	20
6.8. Rear Cover	21
6.9. Pump	22
6.10. Process Fan.....	24
6.11. Rear Panel.....	25
6.12. Rear Isolation Group	27
6.13. Rear Bearing Group	28
6.14. Water Tank Housing.....	29
6.15. Drum.....	30
6.16. Motor	31
6.17. Capacitors.....	33
6.18. Belt	34
6.19. Humidity Sensor	35
6.20. Door latch.....	36

6.21. Plinth	37
6.22. Cooling Fan	38
6.23. Plinth Cover	39
6.24. Door	40
6.25. Drum Bearing Wheel	41
6.26. Drumlight.....	42
6.27. Front Panel	43
6.28. Door NTC	44
6.29. Side Bracket.....	45
6.30. Front Shield	46
6.31.Front Isolation Foam	47
6.32. Cable Group.....	48
7. 7. COMPONENT SPECIFICATIONS AND MEASUREMENTS	50
7.1. Motor	50
7.1.1. Motor Measurements	51
7.2. Pump	52
7.2.1 Pump Measurements	53
7.3. Electronic Card	54
7.4. Door/Compressor NTC Sensor	54
7.4.1. Door NTC Sensor Measurements	55
7.5. Compressor	55
7.5.1. Compressor Measurements	57
7.6. Door Latch	58
7.6.1 Door Latch Measurements.....	58
7.7. Humidity Sensor	59
7.7.1 Humidity Sensor Measurements.....	59
7.8. Cooling Fan	60
7.8.1. Cooling Fan Measurements.....	61
7.9. Drumlight.....	61
8. TROUBLESHOOTING	62

1. OVERVIEW AND WORKING PRINCIPLE

1. Top Plate
2. Control Panel
3. Loading Door
4. Plinth
5. Plinth opening slot
6. Ventilation grills
7. Adjustable feet
8. Plinth cover
9. Type plate
10. Lint filter
11. Drawer Cover

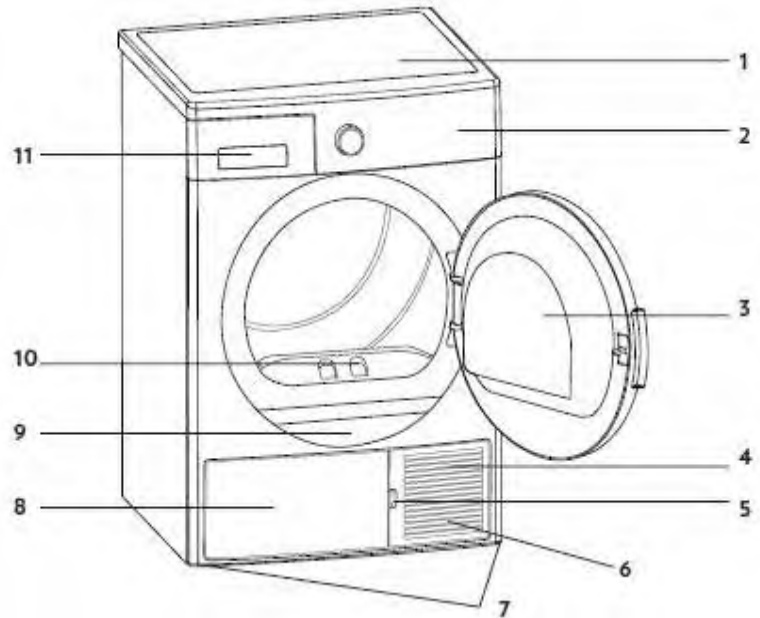

1.2. Working Principle:

In the heat pump dryer machine, heated air is sent to the wet laundry in the drum from the heater side of the coil which called by condenser. The humidity of the laundry is taken and reaches the cold side of the coil which called by evaporator via filter. With a compressor, refrigerant is passed through inside of the tubes of coils both condenser and evaporator. A capillary causes resistance against to refrigerant flow. By this way, the evaporator surface is cooled and condenser surface is heated. The hot and humid air from the drum is reached cold evaporator surface and the humidity on it is left as water. The condensing water in the evaporator is pumped to the water tank by the pump.



HP T3 PANEL SERVICE MANUAL

2. TECHNICAL SPECIFICATIONS

Manufacturer	Vestel White Goods	
Capacity (max)	7 kg	8 kg / 9kg
Height	Min: 845mm Max: 855 mm	Min: 845mm Max: 855 mm
Depth	563 mm	609 mm
Width	596 mm	596 mm
Net weight (with plastic door)	44,8 kg	46,8 kg
Net weight (with glass door)	46,8 kg	48,8 kg
Voltage	220-240 V	
Working Temp.	+5°C - +35°C	
Power	1000 W	

3. INSTALLATION

3.1. Issues that should be informed to customer

1. Drying machine must be grounded.
2. Lint filter must be cleaned after each use
3. Water tank must be unloaded after each use
4. Even if the heat exchanger cleaning warning les is not on : clean the heat exchanger after every 30 drying processes or once a month
5. The amount of laundry should be appropriate to program.
6. Use this product only for laundry with a label that indicates it is suitable for drying.
7. Children should not play with appliance.
8. This product contains environmental friendly but flammable **R290** gas. Keep open flame and fire sources away from the product.
9. Ventilation grills should not be closed.
10. The service life time of tumble dryer is 10 years.
11. Adjustable feet should not be removed.
12. There should not be lockable or sliding door in the installation area
13. Never spray or pour water onto the dryer to wash it. There is a risk of electric shock.

Please ensure that customer reads the user manual

1. Check the environmental conditions. (Voltage, current etc.)
2. Ensure that product is used correctly
3. Check the machine with **Service Auto Test**. If the system displays failure code, find the corresponding code in the failure code list then act according to this.
4. Check the electronic connections



HP T3 PANEL SERVICE MANUAL



4. CONTROL PANEL AND PROGRAM SELECTION TABLE

4.1. Control Panel



Display Symbols

Water tank warning indicator	
Lint filter cleaning warning indicator	
Heat exchanger cleaning warning indicator	
Extra Dry	
Cupboard Dry	
Iron Dry	
Drying level 1	
Drying level 2	
Drying level 3	
Drying level 4	
Delay Timer	
Anti-crease 60'	
Anti-crease 120'	

Drying Step Display:	
Drying	
Iron dry	
Cupboard dry	
End	
<p>The electronic display shows the drying steps throughout the program. Every time a program step starts, the relevant drying step light turns on. Once the drying step is complete, the relevant drying step light turns off.</p>	
Energy Consumption Display	
<p>The energy consumption display shows the energy consumption of the selected program. The bigger the display, the more the energy consumption. The energy consumption level increases or decreases depending on the fabric type, duration of the selected program, the drying level and the spinning speed.</p>	

Delicate	
Buzzer Cancel	
Start and pause	



HP T3 PANEL SERVICE MANUAL



4.2. Program List

KNOB POSITION	PROGRAM
1	Cottons
2	Synthetics
3	Delicate
4	Mix
5	Towels
6	Hygiene
7	Time Drying*
8	Baby Care
9	Duvet
10	Extra Silent
11	Outdoor
12	Wool
13	Refresh
14	Express 34 '
15	Shirts 20 '
16	OFF

***The machine has humidity sensor that detects whether the laundry dry or not. At the programs that work with humidity sensor laundry does not dry in fixed time. Duration is constantly updates according to humidity data taking from laundry.

*****Time Drying Program:** Humidity sensor is deactivated. The program ends when the time is up, without checking the humidity of the laundry.

*****Express 34' / Shirts 20 ':** Humidity sensor is activated. The program time may extend, if the customer use different laundry according to the load in the program description.

*****Delicate:** Delicate fabrics are dried for a longer time at a low temperature.

*****Spin Speed Selection :**For the laundry to be dried, set the spin speed on the washing machine where you washed the laundry. This way, it is ensured that the estimated drying time is more accurately displayed.



HP T3 PANEL SERVICE MANUAL



4.3. Children's Safety

There is a child lock option to avoid changes in the program flow when keys are pressed during the program. To activate child lock, press and hold "Anti-Crease" and "Option" keys simultaneously for 3 seconds. When the child lock is active, all keys will be deactivated. Child lock will be deactivated automatically at the end of the program. When the child lock is being activated/deactivated, "CL" will flash on the display for 2 seconds and an audio warning will be heard. Warning: when the product is running or the child lock is active, if you turn the program selection knob, you will hear an audible warning. Even if you set the program knob to another program, the previous program will continue running. To select a new program, you need to deactivate the child lock and then set the program selection knob to "Cancel" position. Then, you can select and start the desired program.

5. FAILURE MODES AND SERVICE AUTOTEST

***Service auto test must be run for every service call.

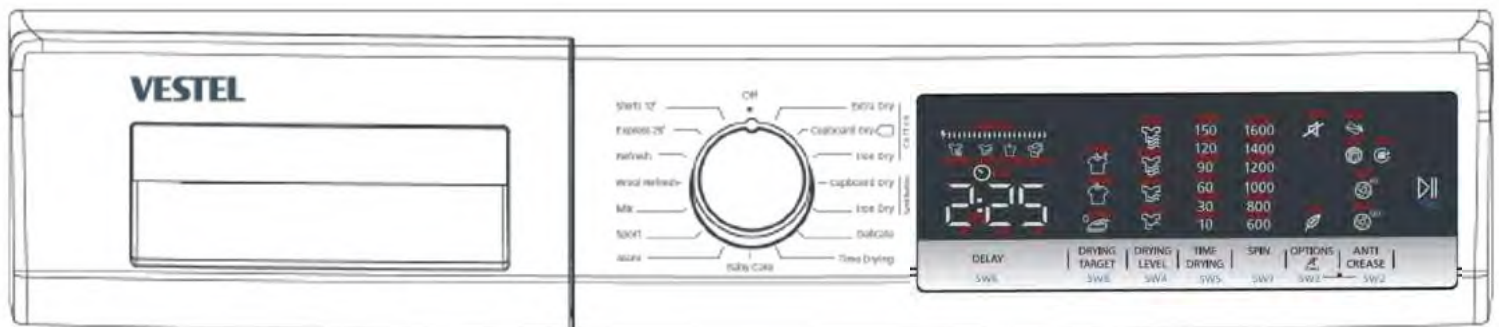



HP T3 PANEL SERVICE MANUAL



5.1. Failure Modes and Warning Leds

T3 HEAT PUMP MODEL ERROR CODES	
ERROR CODE	REASON
E00	T3 UI board doesn't receive communication from mainboard
E03 / 	Aquaswitch connector is disconnected
E04	Compressor connector is disconnected
E05	Compressor NTC connector is disconnected
E06	Door NTC connector is disconnected
E07	Motor connector is disconnected, motor is locked
E08	Voltage fluctuation

Notes For Service autotest:

*Service can not pass the current step before completing the minimum duration

*When minimum duration for each step (5 sec) is completed, filter led makes slow blink to indicate that service can pass the next step

*For error codes, leds must make fast blink



HP T3 PANEL SERVICE MANUAL



5.2. Service Autotest Steps

STEPS	Control	Minimum Step Duration*	Error code	Led Indication	Possible Errors
The Routine to Enter Servis Autotest	<p>Set program knob at position 3. Push SW5 button. Keeping SW5 button pushed, turn program knob to position 1. After 3 sec, SAU is shown in display. Then press Start/Pause button. Machine enters to service autotest.</p> <p>When knob positioned to program 2, control steps starts.</p>	5 sec	-		
Step 2 (Knob Position 2)	Dryer check Aquaswitch, if aquaswitch ON go to next step (pump activation), if aquaswitch OFF give water tank full error	10sec	E03	-	<p>*Aquaswitch connector is taken out</p> <p>*Aquaswitch connector is short circuit</p> <p>*Styrofoam is borken or not</p>
Step 3 (Knob Position 3)	Pump is on	5 sec	-	-	<p>Service must pour water to pump reservoir and check whether water is pumped to tank. If water is not pumped to water tank;</p> <p>*Pump connector is taken out</p>



HP T3 PANEL SERVICE MANUAL



Step 4 (Knob Position 4)	Motor CCW (Tumble CW)- Motor stops	10 sec	-	-	Service must check whether tumble is moving to CW. If not; *Motor connector is taken out *Motor might be locked *Motor belt might be dislocated
Step 5 (Knob Position 5)	Motor CW (Tumble CCW) - Motor stops	10 sec	-	-	Service must check whether tumble is moving to CCW *If tumble is moving to CW again, then motor relay short circuit CCW
Step 6 (Knob Position 6)	Check Heater NTC if heater NTC T=255	5 sec	E05	-	*Heater NTC connector is taken out or short circuit
Step 7 (Knob Position 7)	Check Door NTC if heater NTC T=255	5 sec	E06	-	*Door NTC connector is taken out or short circuit
Step 8 (Knob Position 8)	Compressor OFF- Motor CCW (Tumble CW) OFF- Cooling fan ON	10 sec	-	-	Service must check power of at the home voltage and fan will be controlled manually by technical service.
Step 9 (Knob Position 9)	Compressor ON- Motor CCW (Tumble CW) - motor off	10 sec	-	-	Service must check power of at the home voltage.
Step 9 (Knob Position 9)	Check conductivity sensor when door is opened and motor is off	5 sec	E01	-	Service puts his hand on the humidity sensor plates and software checks sensor data *If sensor data=0, humidity sensor connector is taken out
Remove the last error (Knob Position 1)		5 sec	DEL	DL is visualized on display and make fast blink for 2 sec for T0.DEL is visualized on display and make fast blink for 2 sec	When the knob positioned to program 1, service will push the both SW4 and SW5 for T0/T1 (child lock mode). When the knob positioned to program 1, service will push the both SW2 and SW3 for T2 (child lock mode).

6. DISASSEMBLY

6.1. Top Plate

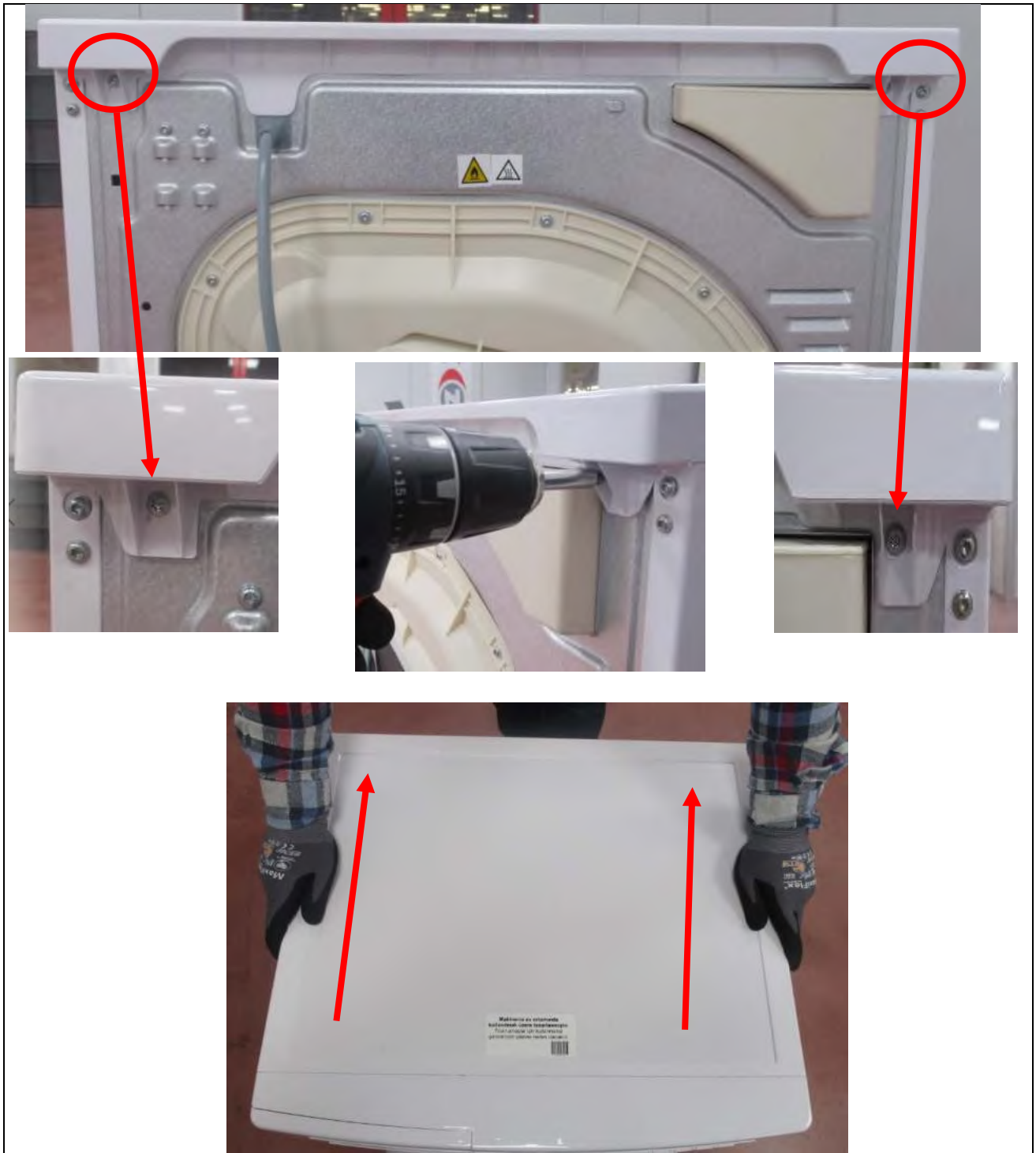

1. Remove two screws that fix the top plate at the back.
2. Remove by pulling the top plate to yourself.

6.2. Control Panel



1. Remove 2 screws from the top
2. After the water tank removed, the plastic screw in the center of the control panel should be removed.

6.2. Control Panel

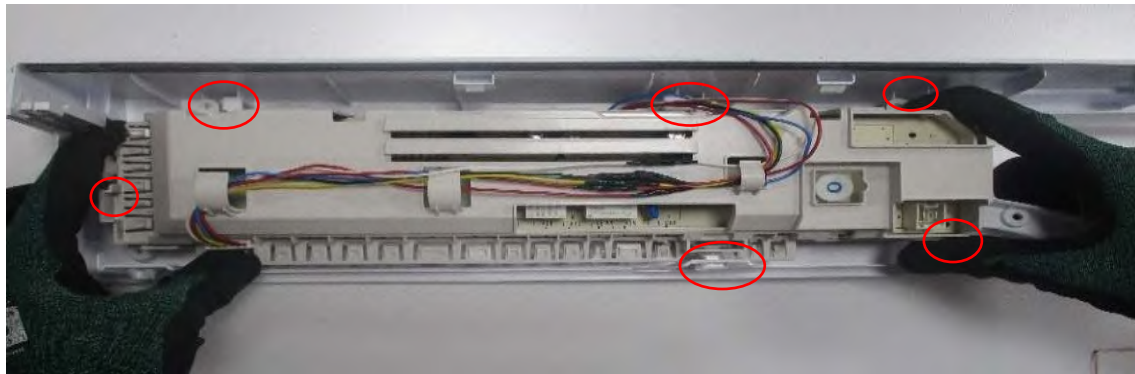

1. After removing the screws on the control panel, the control panel is removed as shown in the photo from the upper support bracket.
2. The cables on the control panel are carefully removed from the cable paths.
3. All sockets which is connected with electronic card must be removed carefully as shown in the photo.

6.3. Electronic Card

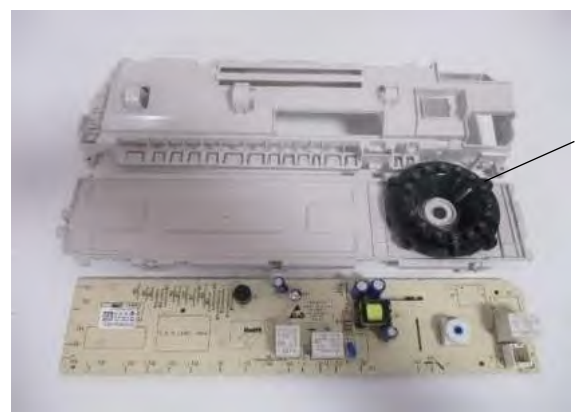
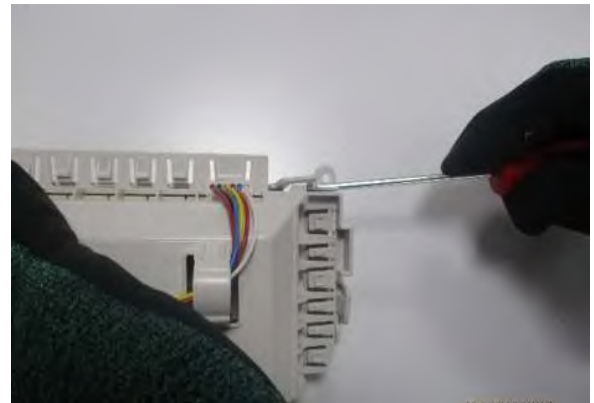
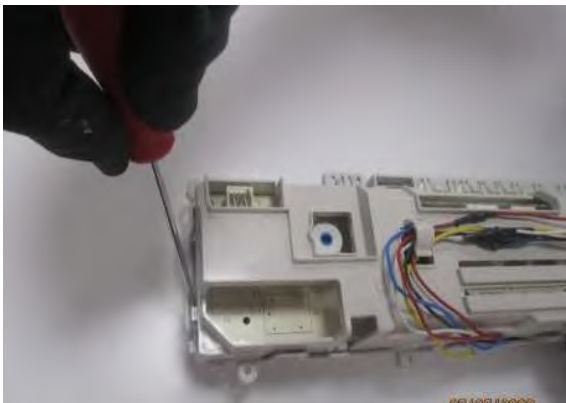
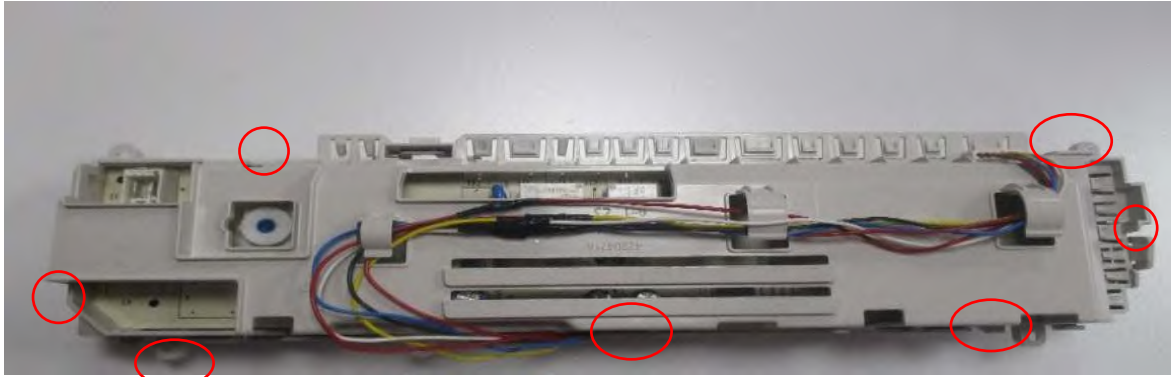

1. To remove the electronic card box (PCB box) from the control panel, it is necessary to remove 6 tabs. As shown in the photo, you can take off the tabs with thin screwdriver.
2. The PCB box is separated from the control panel.
3. Jog dial part only available on some models.

6.4. UI Card

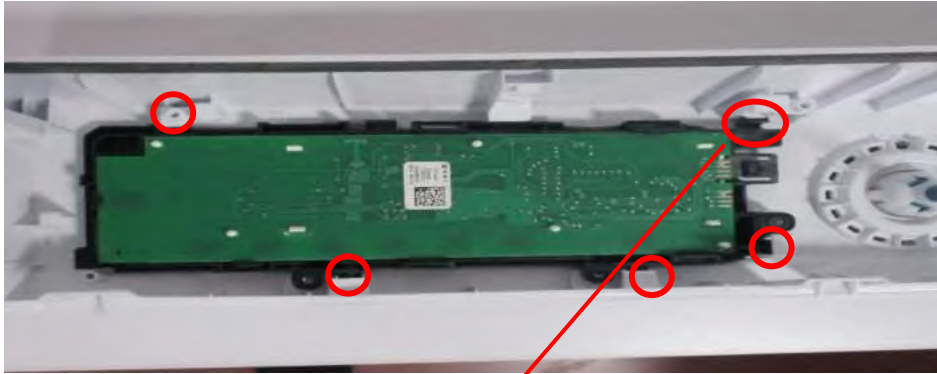

1. UI card on control panel is disassembled as shown in photo

6.5. Side Panel



1. Remove 10 screws on side panels

6.5. Side Panel



2. Remove 2 screws from front
3. It should not be forgotten to take bottom screw (2 screws)
4. Remove the side plate which is pulled out screws , by pushing up

6.6. Supply Cable



1. Remove the supply cable brown and blue cable socket.
2. Remove the terminals with tool as shown in the photo
3. Remove supply cord by pushing up

6.7. Emi Filter



1. Remove EMI filter sockets
2. Remove the terminals with tool as shown in the photo
3. Remove the EMI filter which is fixed with 2 screws to the rear panel

6.8. Rear Cover



1. Remove all screws shown in the photo.

6.9.Pump



1. Remove the screw on pump cover
2. After opening the pump holder plastic cover, Remove 2 hoses that is connected with pump.
3. Remove aqua switch and pump socket.
4. Remove the pump holder plastic from basement plastic as shown in the photo

6.9.Pump



5. Push the pump from plastic.
6. There is a float in the pump housing as shown in the photo.

6.10.Process Fan



1. Hold the fan as shown in the photo.
2. First remove washer and nut then remove the process fan.

6.11. Rear Panel

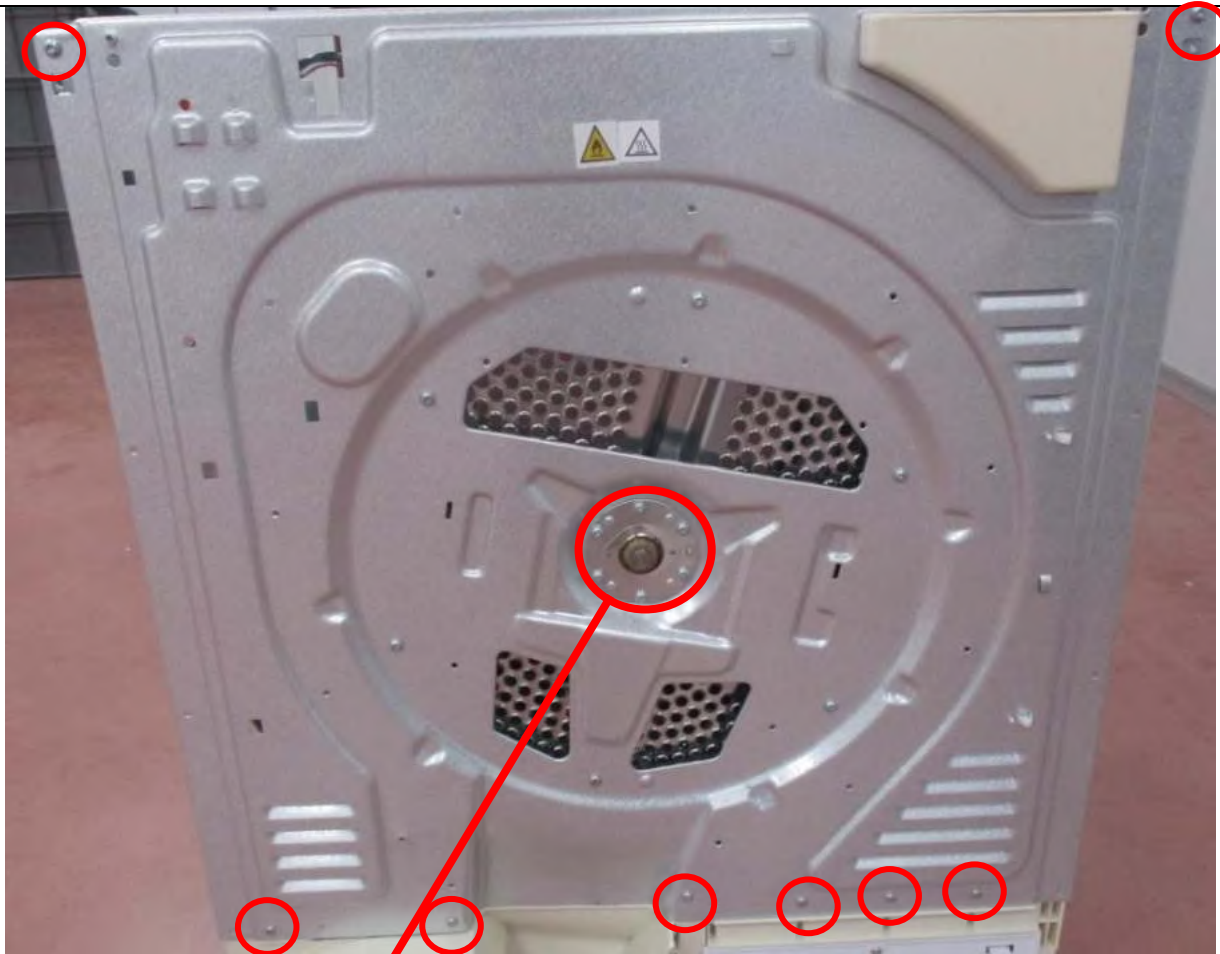

1. Remove segment on rear panel.
2. Remove 8 screws from panel

6.11. Rear Panel



1. Remove hoses from rear panel
2. Remove the rear panel by pulling to yourself.

6.12.Rear Isolation Group

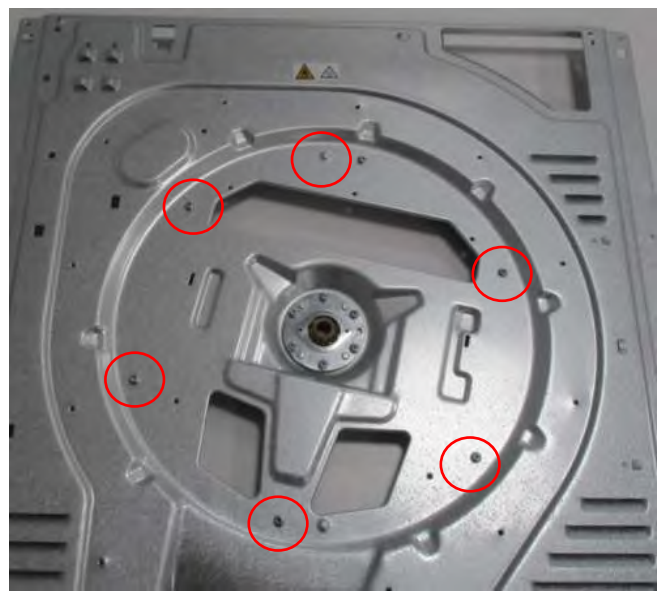
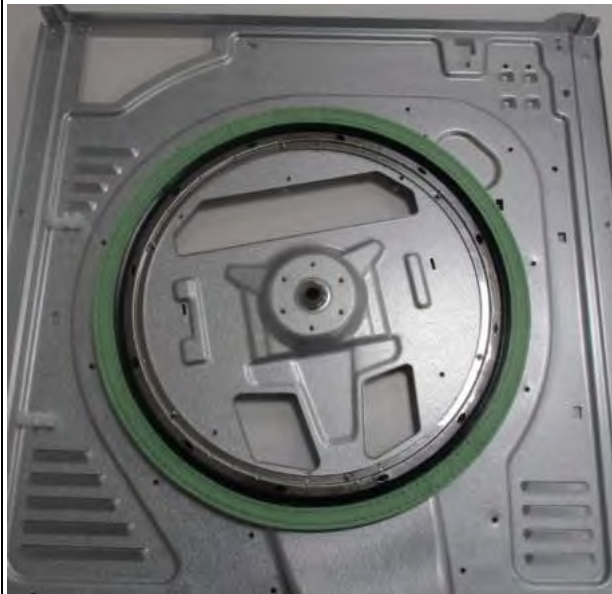

1. For disassembling the rear Isolation group on rear panel, screws are shown in the photo should be removed.

6.13. Rear Bearing Group



1. For disassembling the rear bearing group on rear panel, screws are shown in the photo should be removed.

6.14. Water Tank Housing



1. Remove 2 hoses from water tank housing.
2. Remove the water tank housing clips.
3. The water tank housing is removed as in the photo.

6.15.Drum

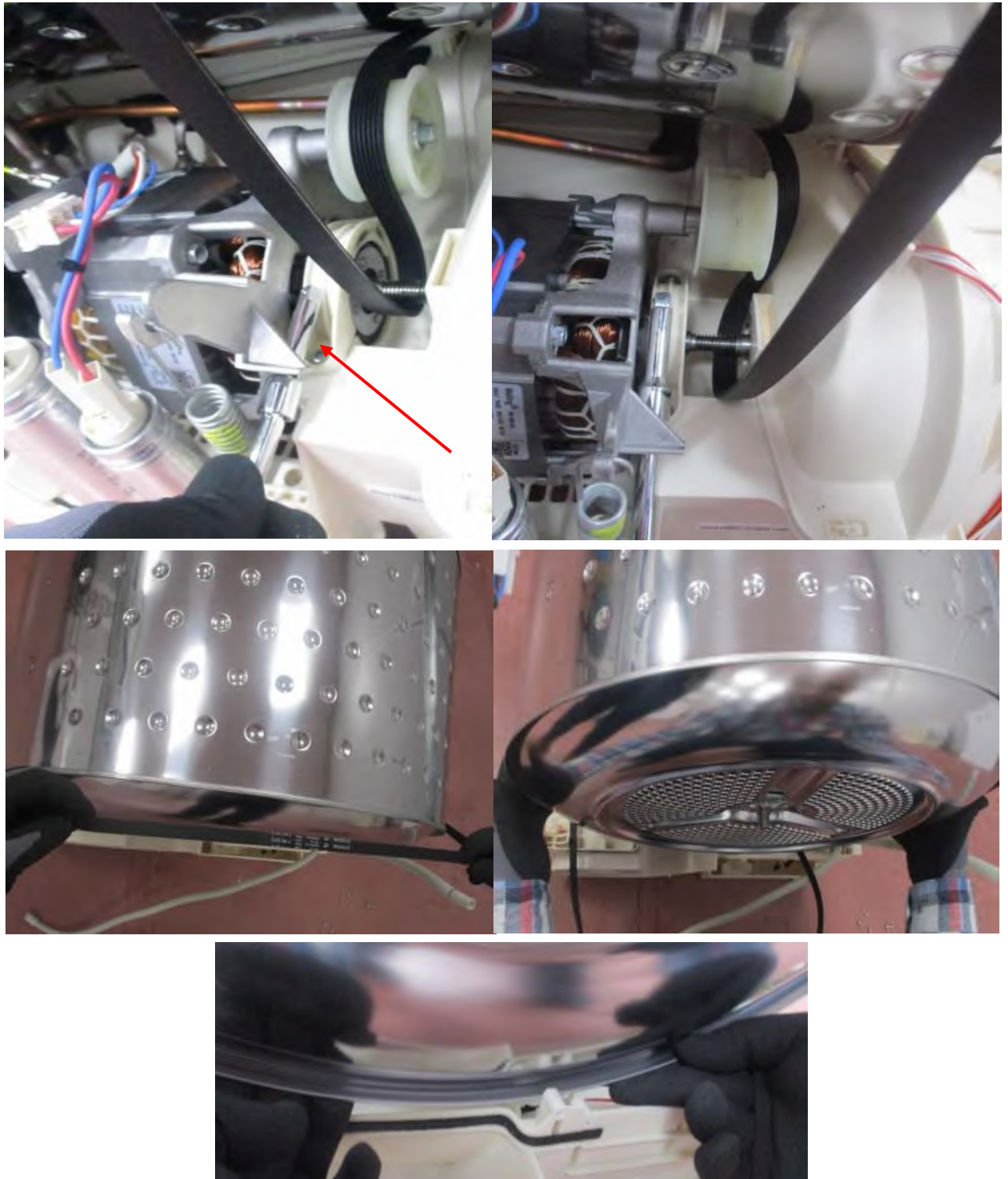

1. Motor should be moved up to prevent to press spring. So, belt will be released as shown in the photo.
2. Remove the belt on the drum
3. Pull up the drum to separate with basement plastic. Then, pull back to remove.

6.16. Motor

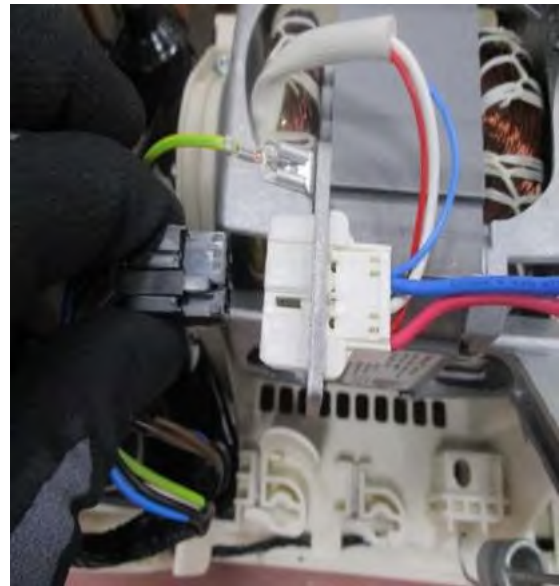
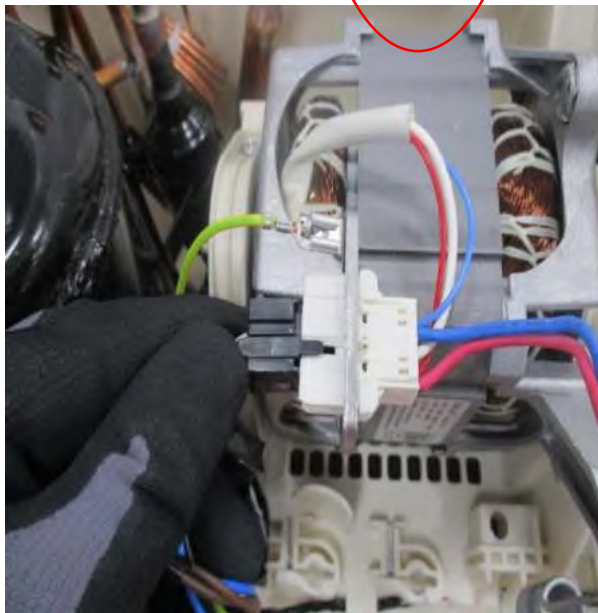
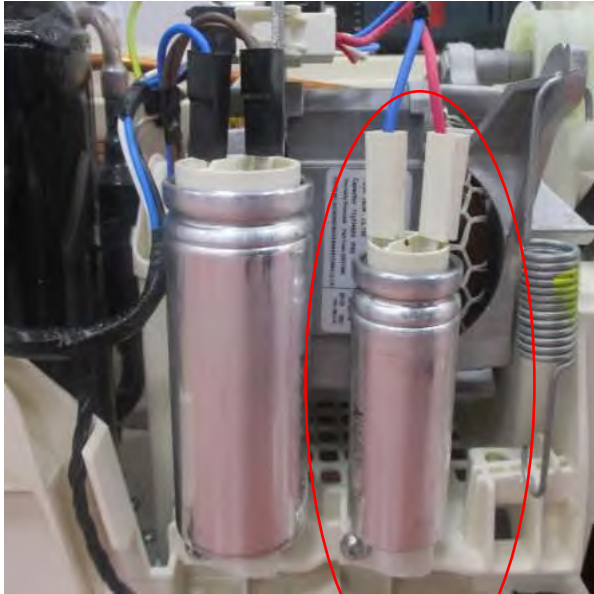

1. Remove capacitor sockets and other sockets from motor.

PS: before removing the motor, process fan should be removed.

You can apply the same instruction to change the belt

6.16.Motor

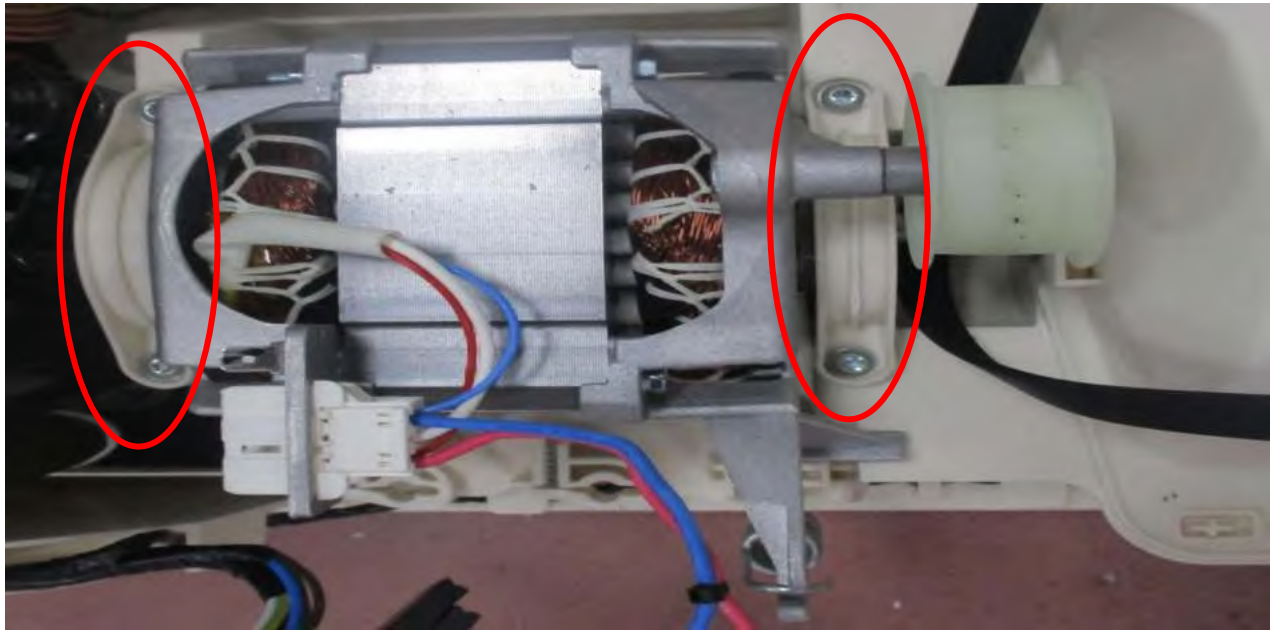

2. Remove 4 screws from motor fixing plastic
3. Take the motor from basement plastic as shown in the photo.

6.17. Capacitors



1. Remove all sockets from motor.
2. Remove the screw on bottom of capacitor then disassemble the capacitor
3. The capacitor is removed by turning.

6.18.Belt

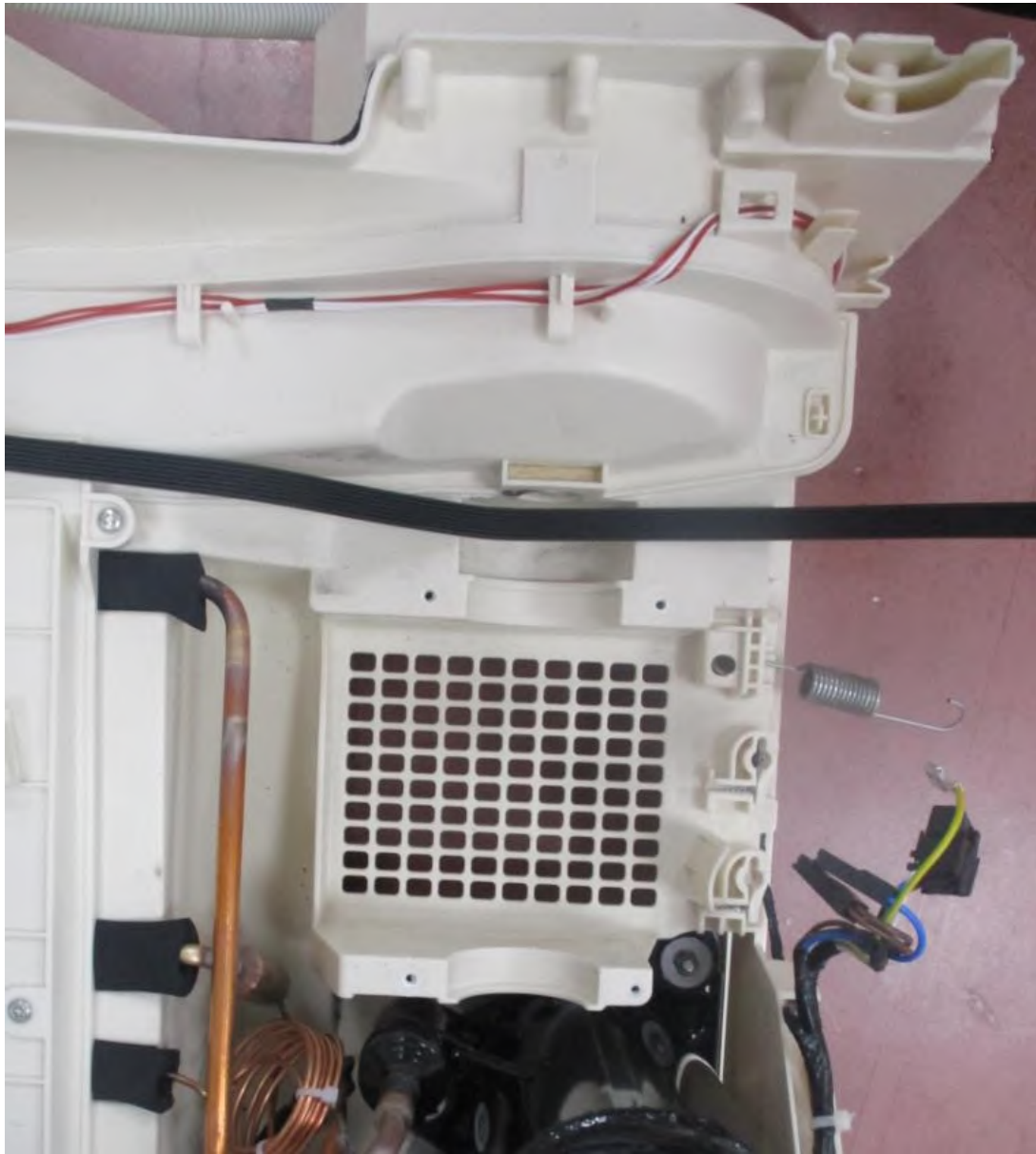

1. After you should remove drum and motor than change the belt.

6.19. Humidity Sensor



1. Remove 5 screws from humidity sensor plastic.
2. Remove the humidity sensor cable as shown in photo.

6.20. Door latch

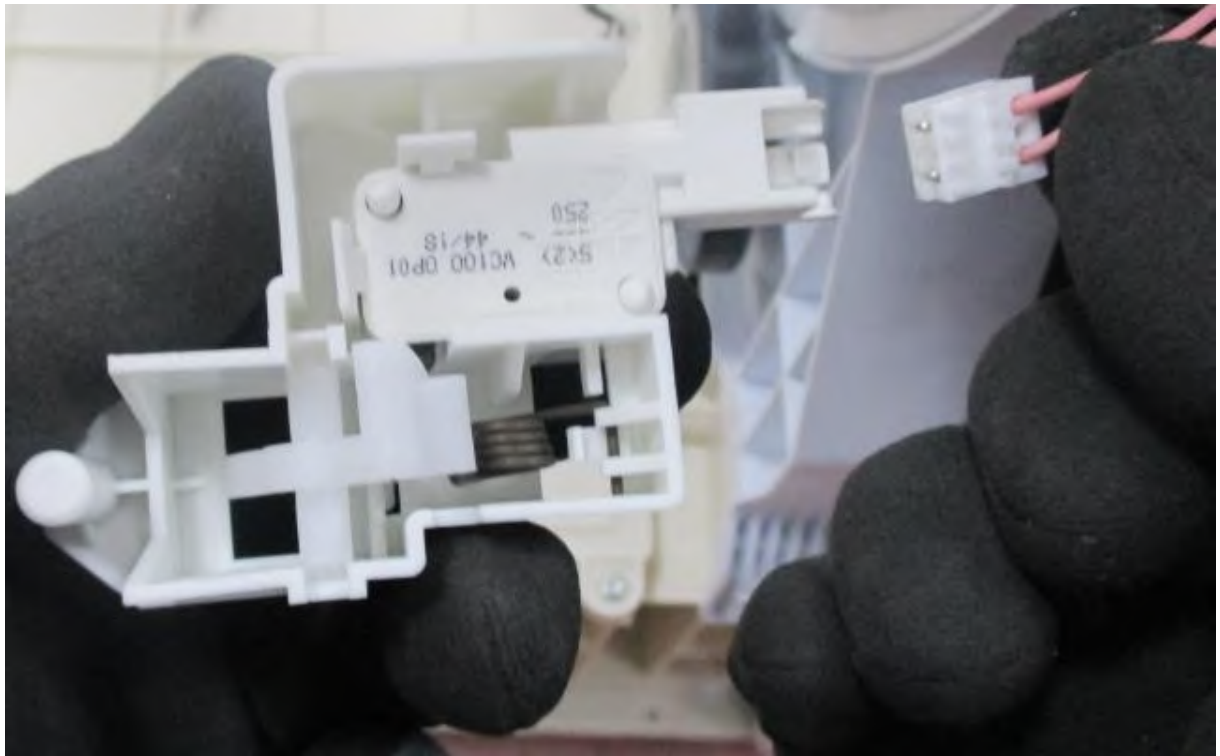
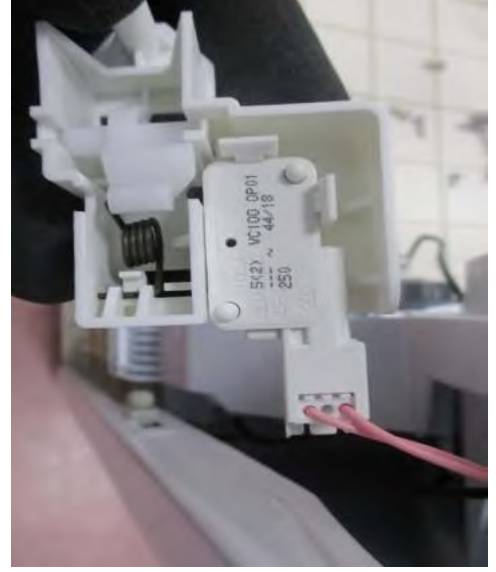

1. Remove door latch screw from front panel.
2. Separate the door latch socket from door latch as shown in the photo.

6.21. Plinth



1. Remove the plinth screw
2. Remove the plinth as shown in the photo

6.22. Cooling Fan

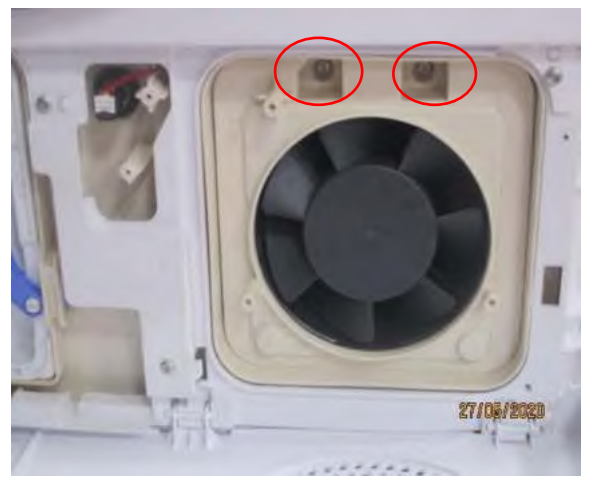

1. Remove screws on cooling fan fixing plastic
2. Remove the cooling fan fixing plastic as shown in the photo.
3. Disassemble the cooling fan by removing the fan screws and fan ground wire.

6.23. Plinth Cover



1. Remove 2 plinth pin on Plinth cover.

6.24. Door



1. Remove 2 screws that fix the door.
2. Pull the door by lifting up.

6.25. Drum Bearing Wheel



1. Remove wheels as shown in the photo

6.26. Drumlight

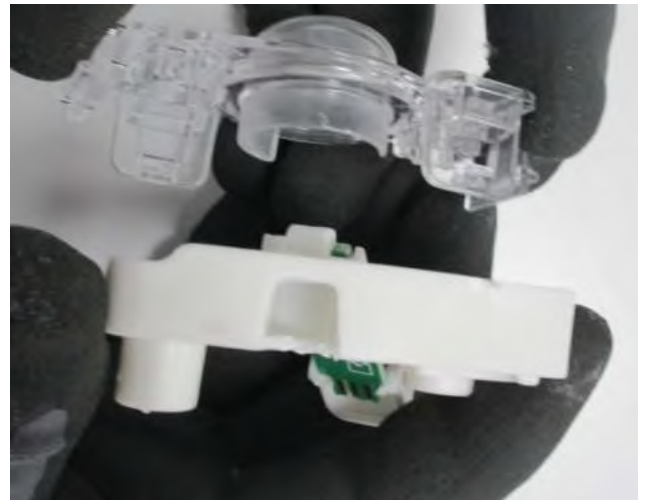

1. Remove Drumlight group from Front Shield
2. Remove the drum light socket.
3. Remove the drum light card.

6.27. Front Panel



1. Remove 16 screws on the front panel
2. While removing the front panel, the cable of the door latch must also be removed.

6.28. Door NTC



1. Remove the socket from NTC sensor on the basement plastic.
2. Remove the NTC from basement plastic by hand or tool

6.29. Side Bracket



1. Remove cable holder plastic clips shown in the photo. (For right side bracket)
2. Remove screw from bracket which is fixing side bracket and top bracket. (Rear panel was removed before.)

6.30. Front Shield

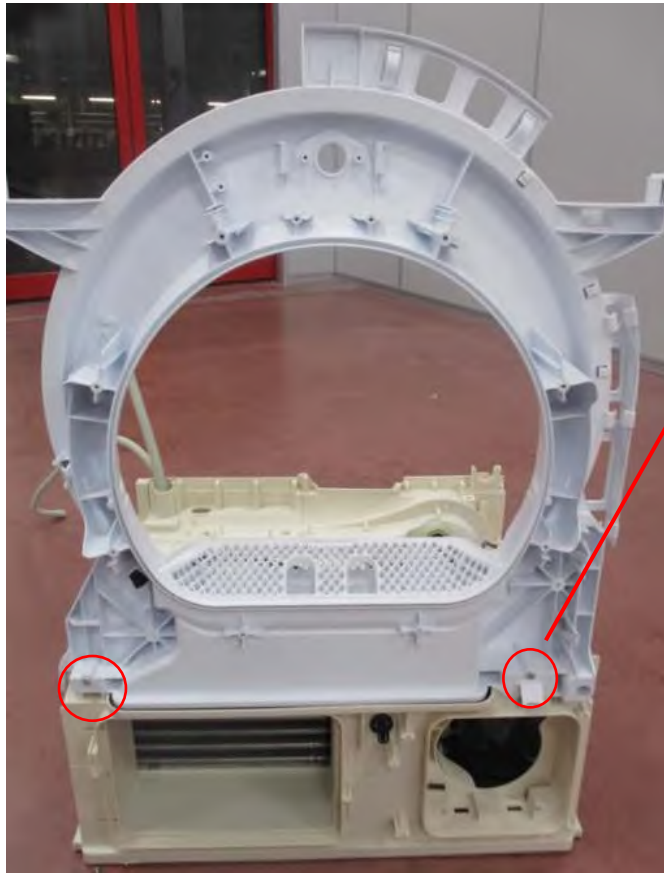

1. Remove 2 screws in the bottom.
2. Open clips on the left side.
3. The front shield should be lifted as shown in the photo.

6.31. Front Isolation Foam

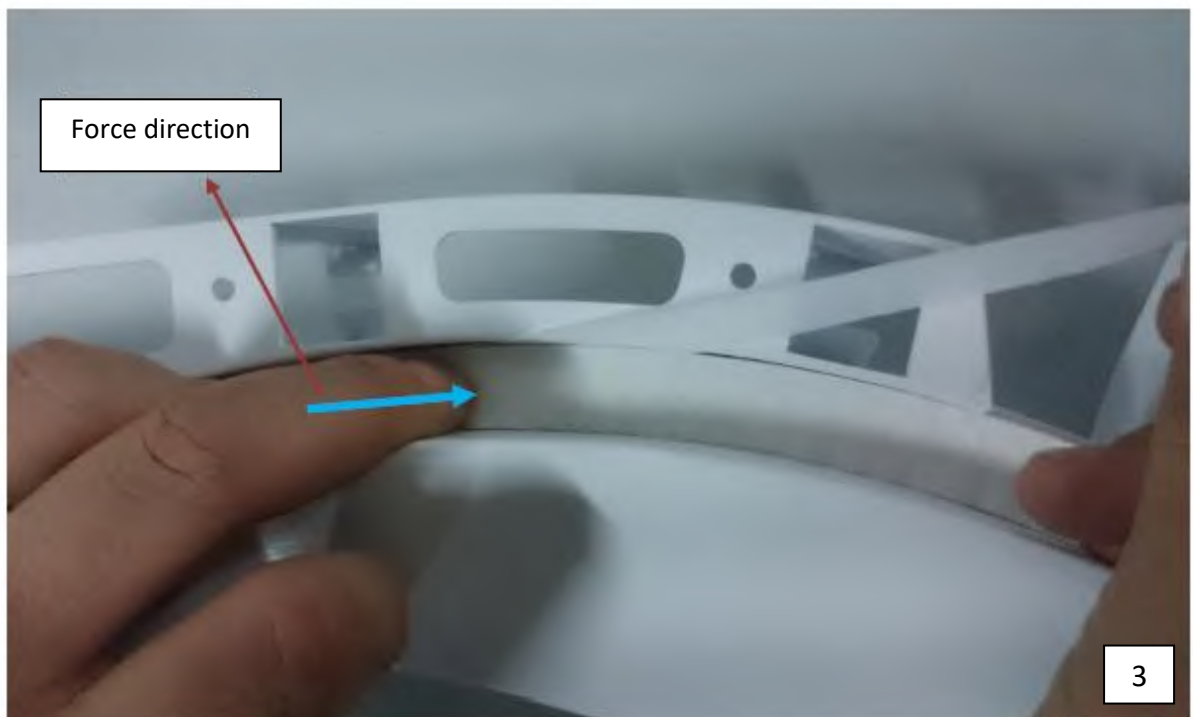
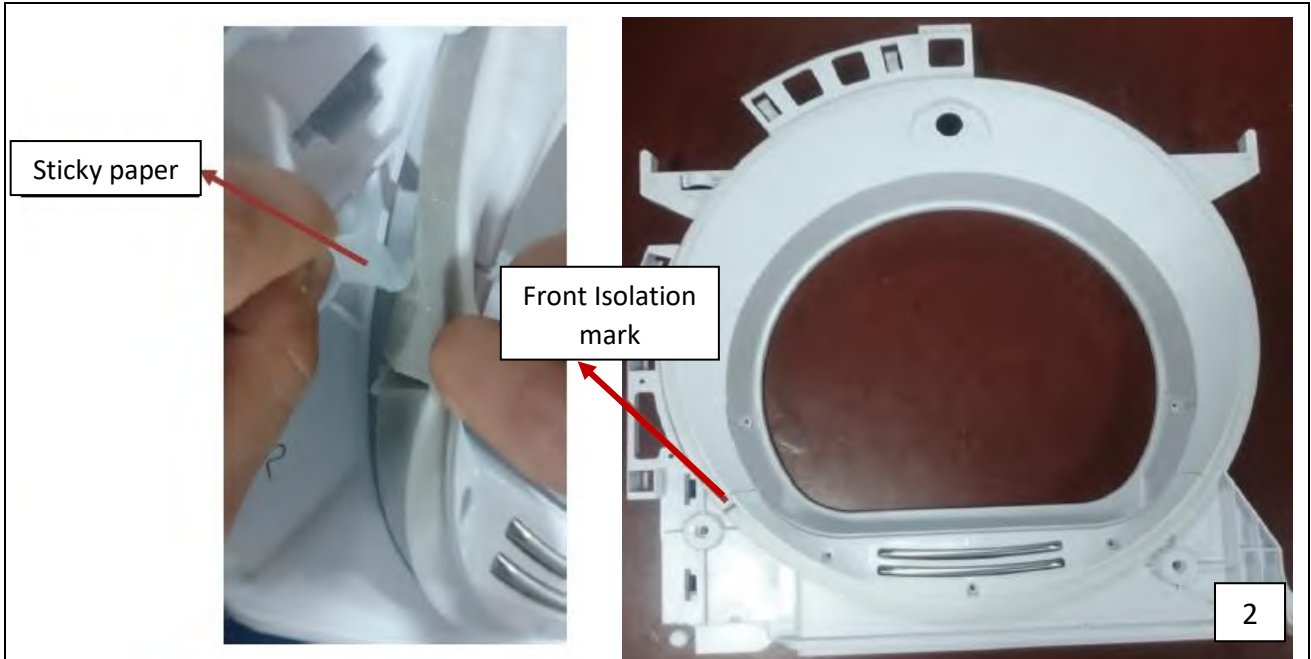

1. It is important to install the new felt correctly after it has been removed from the slot at the front shield.
2. Before Sticky paper is opened, front isolation foam should be placed to slot on front shield. Front isolation foam mark should be on left bottom of front shield.
3. Stick the foam on front shield as shown in the photo.
4. Isolation should be centered on slot

6.32. Cable Group

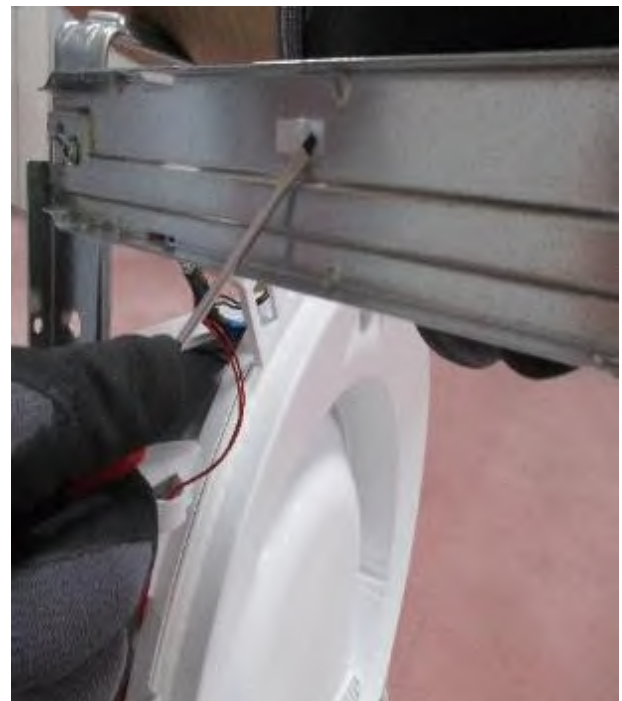
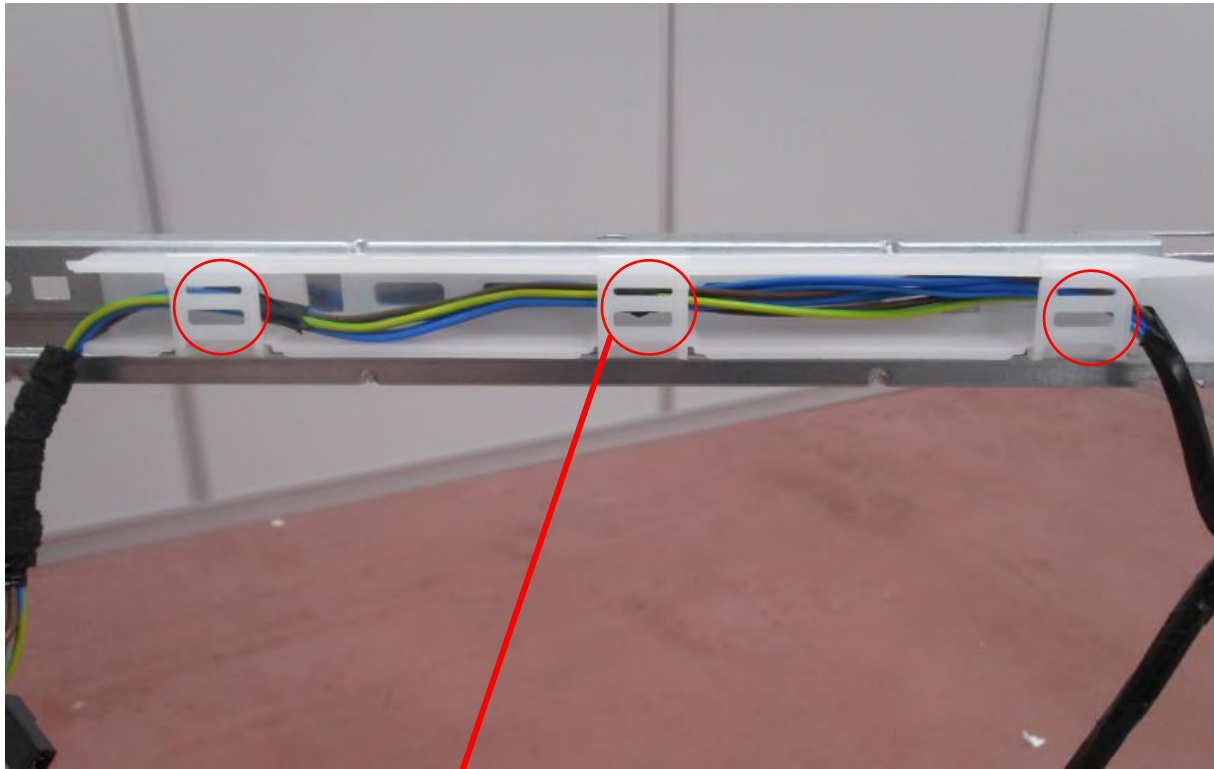

1. Open the cable holder plastic clips on side bracket.
2. Remove cable holder plastic fixing clips as shown in the photo.

6.32. Cable Group

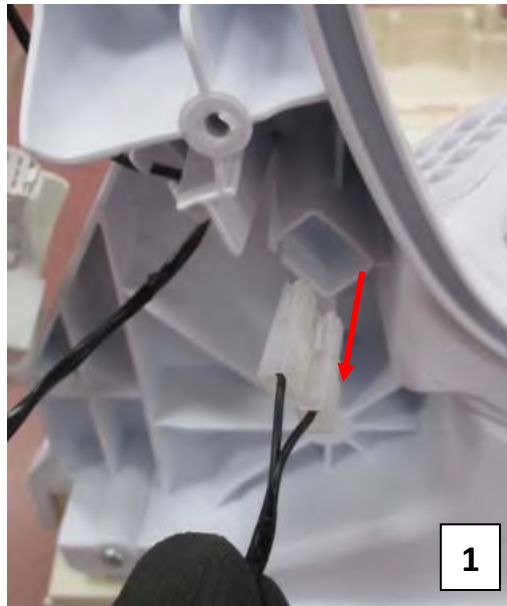

1. Humidity Sensor Cable
2. Door Latch Socket Cable
3. Cable Group of Front Shield

4. Compressor NTS Socket
5. Compressor Ground Cable
6. Compressor Socket

7. 7. COMPONENT SPECIFICATIONS AND MEASUREMENTS

7.1. Motor

The dryer has an asynchronous motor. In the photo on the right, the socket on the motor are shown to be measured by multiple counters. It is driven with triac via the electronic card (to give energy) and relay (for direction control).

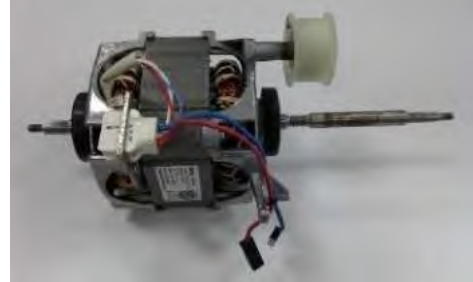

Technical Features

Type: single-phase asynchronous motor
 Power: 200 W (Unloaded drum)
 Main windings: 21.5±7% (20 °C temp.)
 Aux windings: 19.5±7% (20 °C temp.)

Motor speed : 2750 rpm (Unloaded drum)
 Drum speed : 52 ± 2
 Capacitor value : 11 µF ± %5

Component Test

- Check whether the motor cable is connected to the motor connector.
- Check the connection of the capacitor cables
- Measure the resistance values and check the capacitor values
- Check whether it is working by connecting via the terminals 1 and 2 (Blue-White) connection
- If it is working, revolution of the drum is measured in unloaded state.

The terminals 1-3 of the motor should be connected with capacitor

Resistance measurement of main winding: Terminal 1 -2 (Blue-White) is measured.

Resistance measurement of aux winding: Terminal 3 -2 (Red-White) is measured.

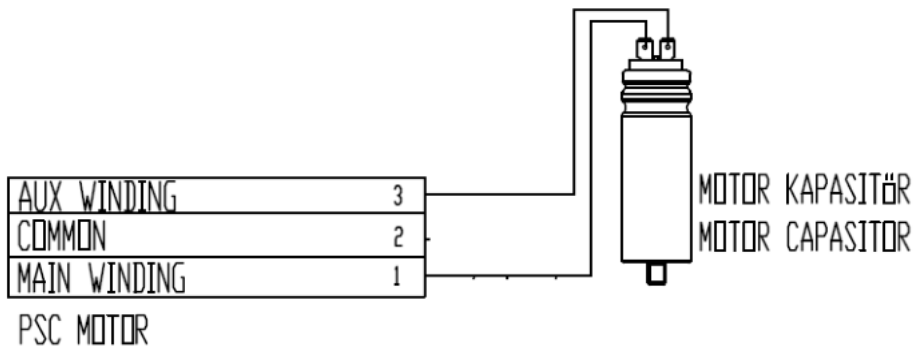

7.1.1. Motor Measurements





HP T3 PANEL SERVICE MANUAL



7.2. Pump

In Tumble Dryer models, the pump is used to transport the water that accumulates in the condensation chamber to tank in the drawer area. One triac is measured on the electronic card.



Technical Features

Resistance : $764 \pm 10\%$ ohm
Voltage: 220-240 Volt
Frequency: 50 Hz

Input Power : 13W max

Component Test

- Check the connection of the pump connector
- Check the pump resistances
- Check whether pump is working, by feeding externally
- If the pump is working, the water in the tank is unloaded by running the pump Then, Unload 500 ml of water from water tank to pump reservoir and check whether water is pumping.
- While pump is working, if water is not reached into water tank, hoses should be checked.

7.2.1 Pump Measurements



7.3. Electronic Card



Technical Features

Electronic card is single sided printed circuit board and CEM-1 material

7.4. Door/Compressor NTC Sensor

Two NTC sensors are used. The NTC resistance decreases when the temperature rises.



Technical Features

Door NTC Resistance : 12 k Ω (Measured from IDC connected to electronic card)
Compressor NTC Resistance : 12 k Ω (Measured from IDC connected to electronic card)

Component Test

- Resistance is measured from IDC connected to electronic card

7.4.1. Door NTC Sensor Measurements

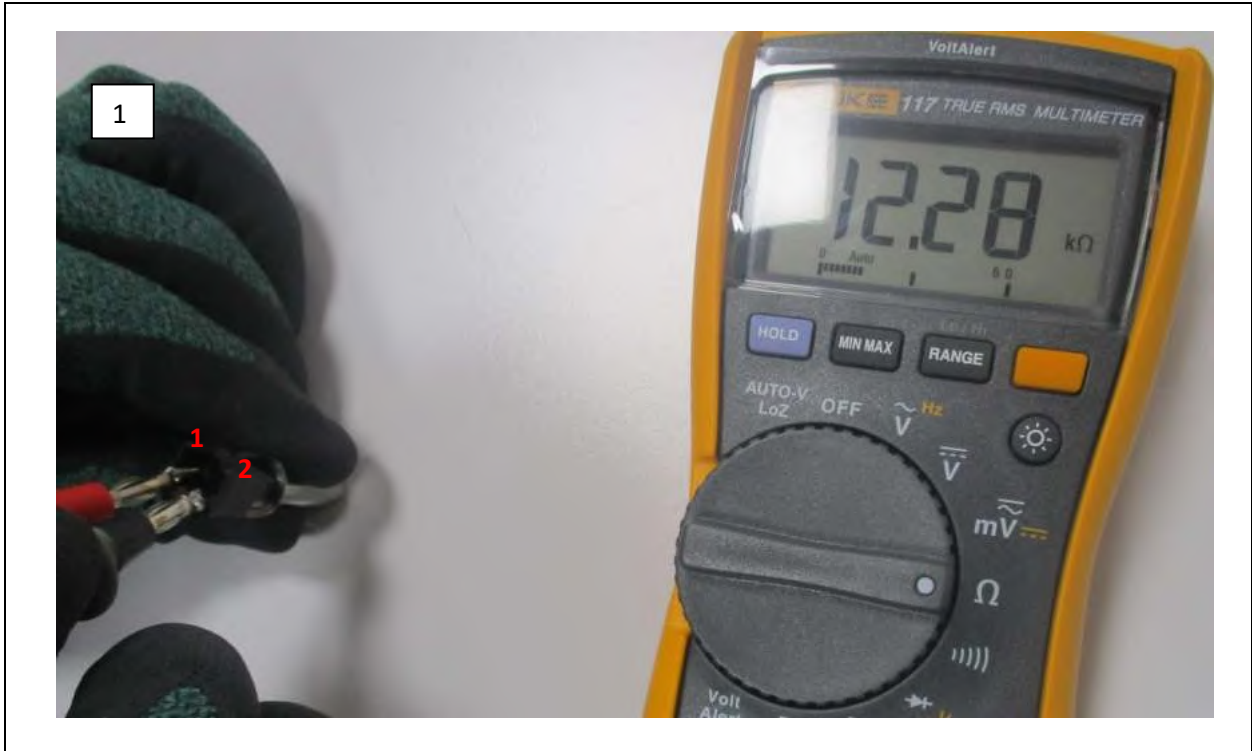

7.5. Compressor

The dryer has an compressor with an asynchronous motor. In the photo on the right, the terminal on the compressor are shown to be measured by multiple counters. It is driven with relay via the electronic card (to give energy) and relay drive the compressor only one direction.



Technical Features

Type: single-phase asynchronous motor
 Power: 350 W (Unloaded drum)
 Main windings: $9.3 \pm 7\%$ (25 °C temp.)



HP T3 PANEL SERVICE MANUAL



Aux windings: $8.75 \pm 7\%$ (25 °C temp.)

Motor speed : 2928 rpm (Unloaded)

Gas Type: R290

Capacitor value : $20 \mu\text{F} \pm 5\%$

Compressor Capacity: $7.8 \text{ cm}^3/\text{rev}$

Component Test

- Check whether the compressor cable is connected to the compressor terminal.
- Check the connection of the capacitor cables
- Measure the resistance values and check the capacitor values
- Check whether it is working by connecting via the terminals S,R and C connection
- If it is working, start the machine and check the drum temperature.

The terminals S and R of the motor should be connected with capacitor.

Resistance measurement of main winding: Terminal C-R is measured.

Resistance measurement of aux winding: Terminal C-S is measured.

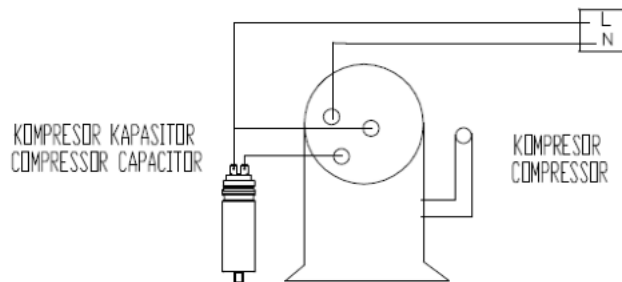

7.5.1. Compressor Measurements



7.6. Door Latch

Door latch locks when the door is closed. It's designed to be opened from inside, in case of children are in the drum



Component Test

- When the door is closed, check whether there is electrical transmission from IDC connected to electronic card
- Check the connection of the component connector

7.6.1 Door Latch Measurements



7.7. Humidity Sensor

The Humidity Sensor measures the amount of dryness of the laundry in the drum.



Component Test

- Each humidity sensor plate is checked whether there is electrical transmission from IDC connected to electronic card.
- Check the connection of the component connector

7.7.1 Humidity Sensor Measurements



7.8. Cooling Fan

The dryer has an cooling fan with an asynchronous motor. In the photo on the right, the terminal on the compressor are shown to be measured by multiple counters. It is driven with triac via the electronic card (to give energy)



Technical Features

Type: single-phase AC fan
 Power: 28 W
 Main windings: 600±7%
 Motor speed : 2600/3000 ±10%

Component Test

- Check whether the cooling fan cable is connected to the fan terminal.
- Measure the resistance values

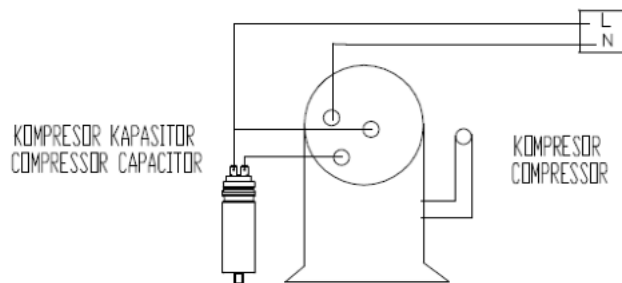

7.8.1. Cooling Fan Measurements

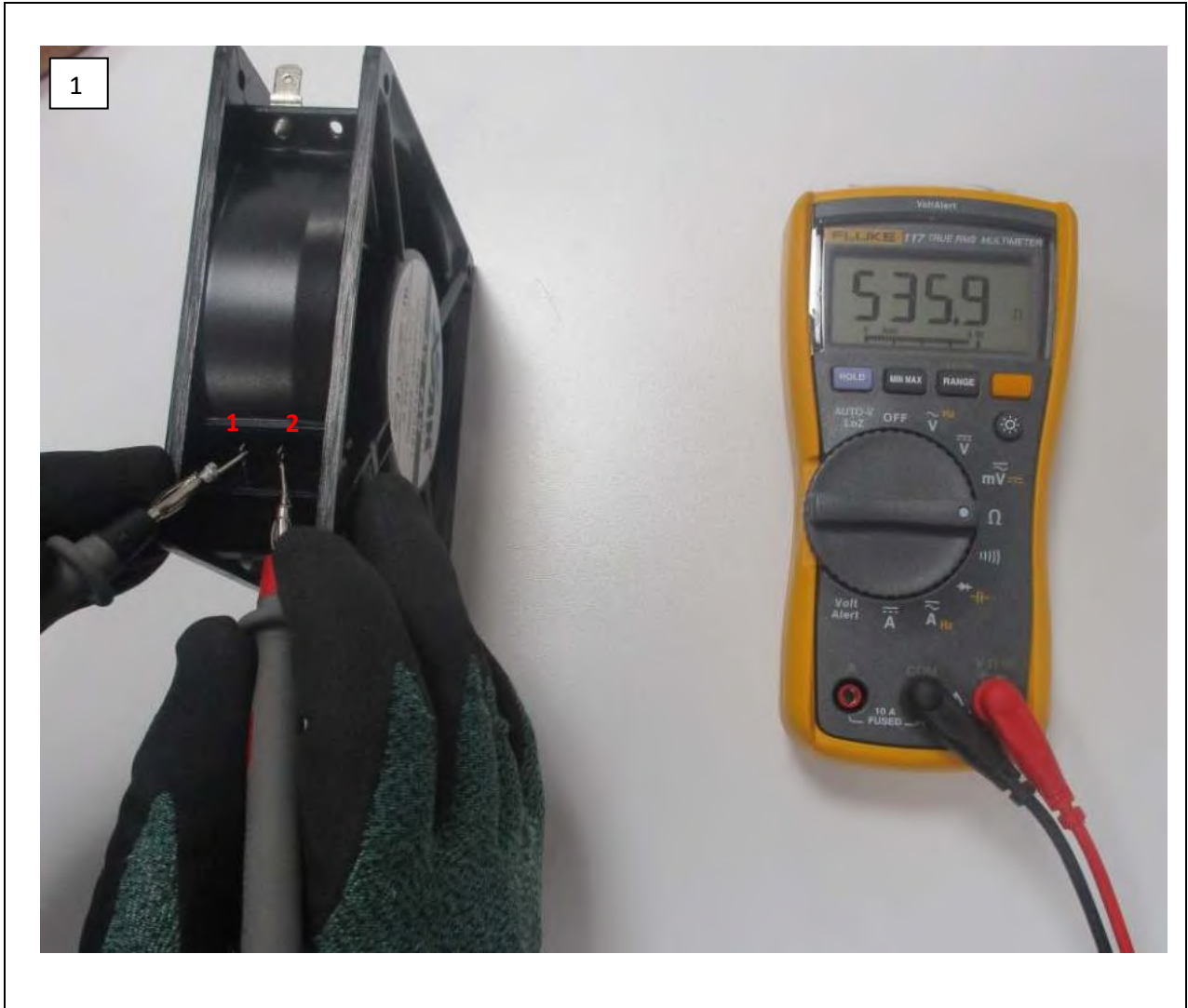

7.9. Drumlight

Drumlight lights inside of the drum



Component Test

Check whether there is electrical transmission from IDC connected to electronic card.



HP T3 PANEL SERVICE MANUAL



8. TROUBLESHOOTING

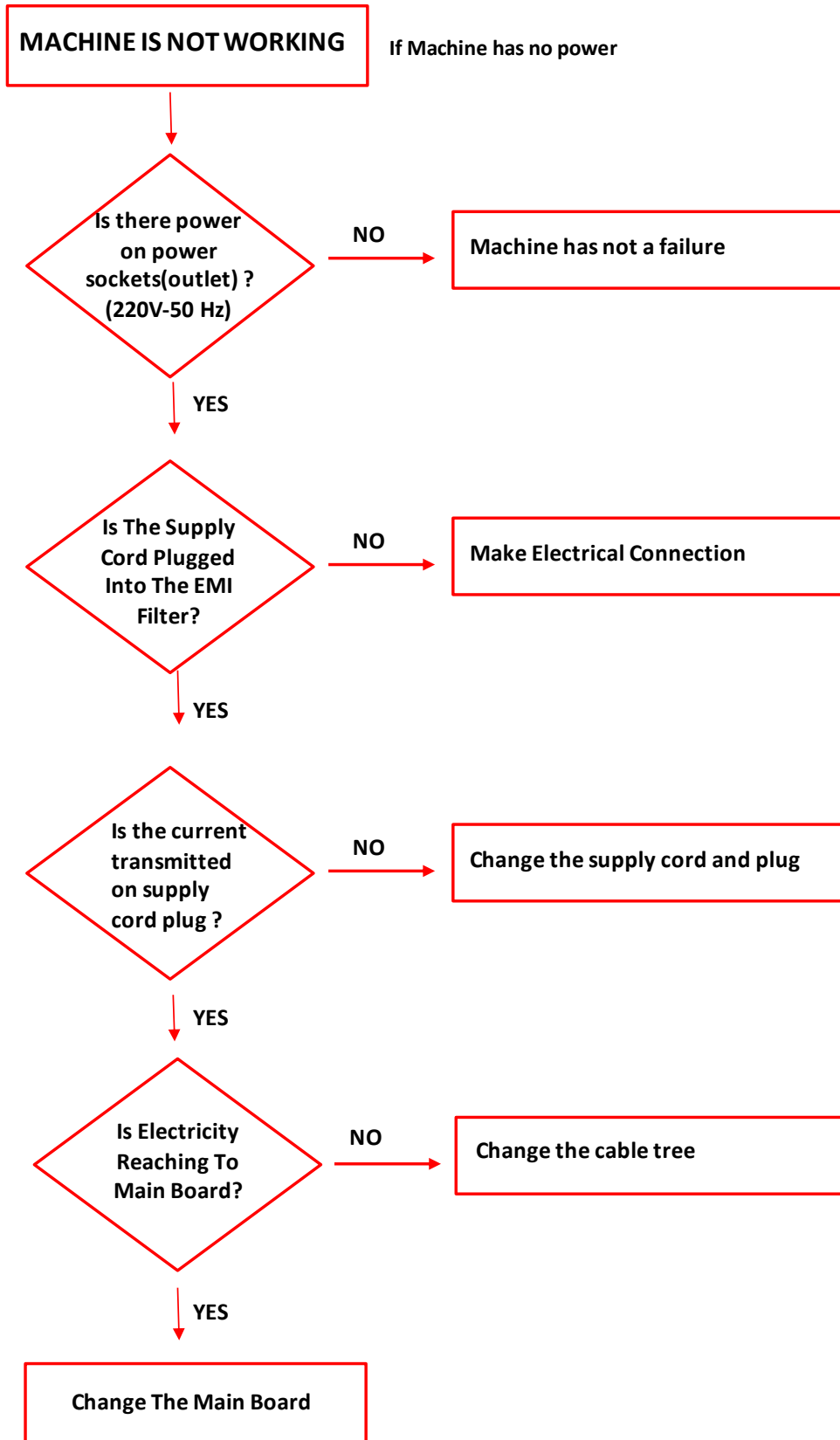

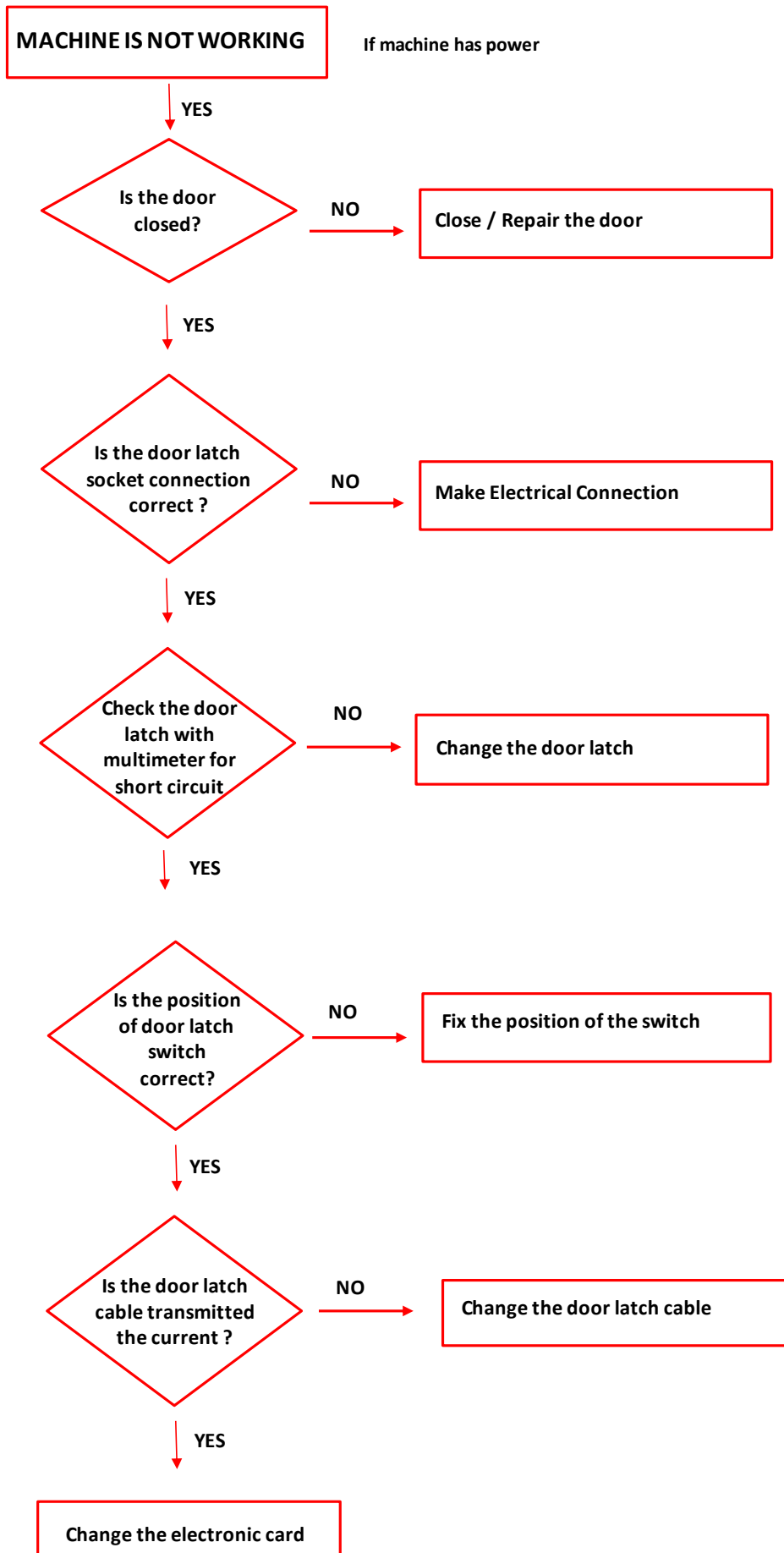



HP T3 PANEL SERVICE MANUAL

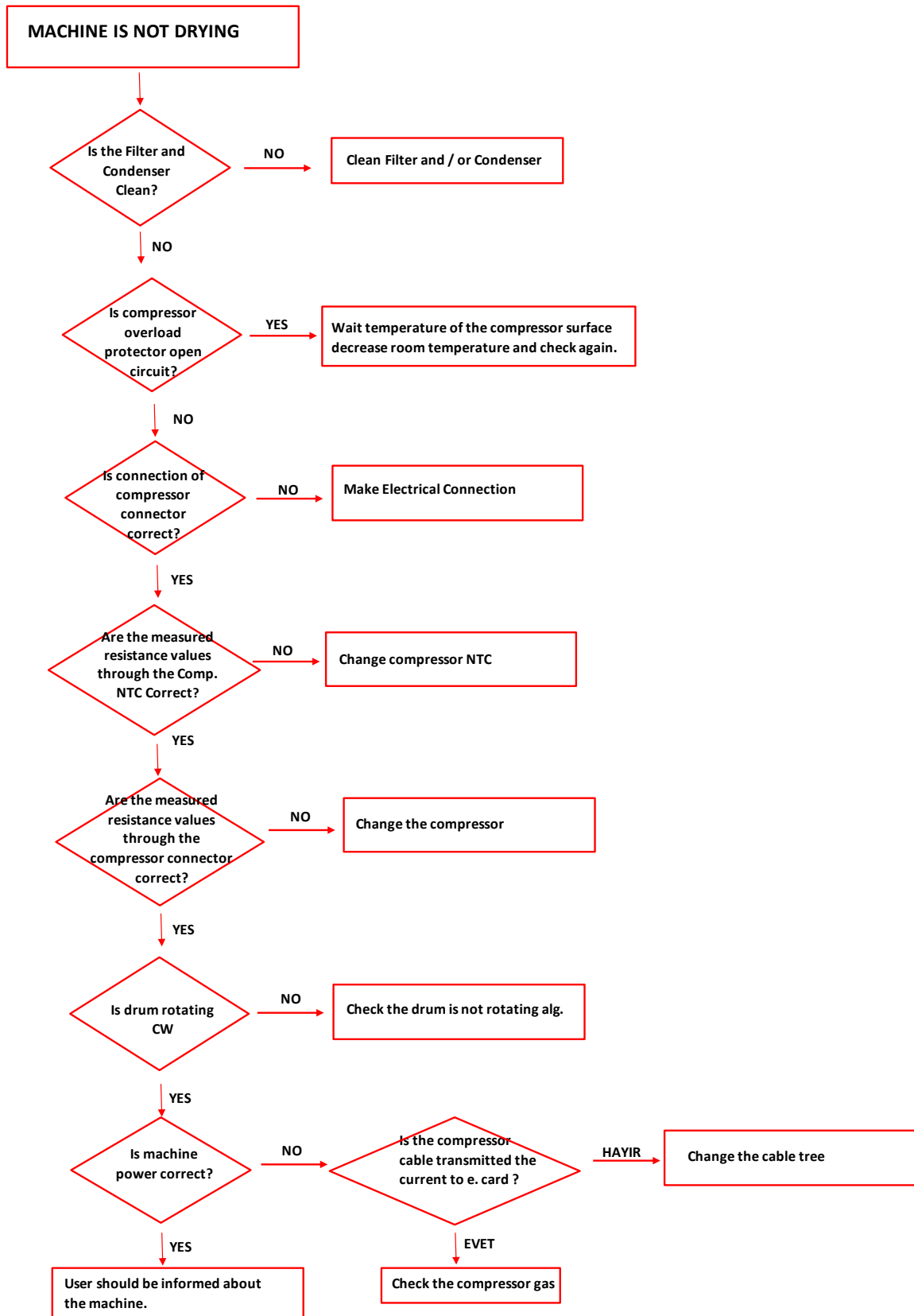



HP T3 PANEL SERVICE MANUAL

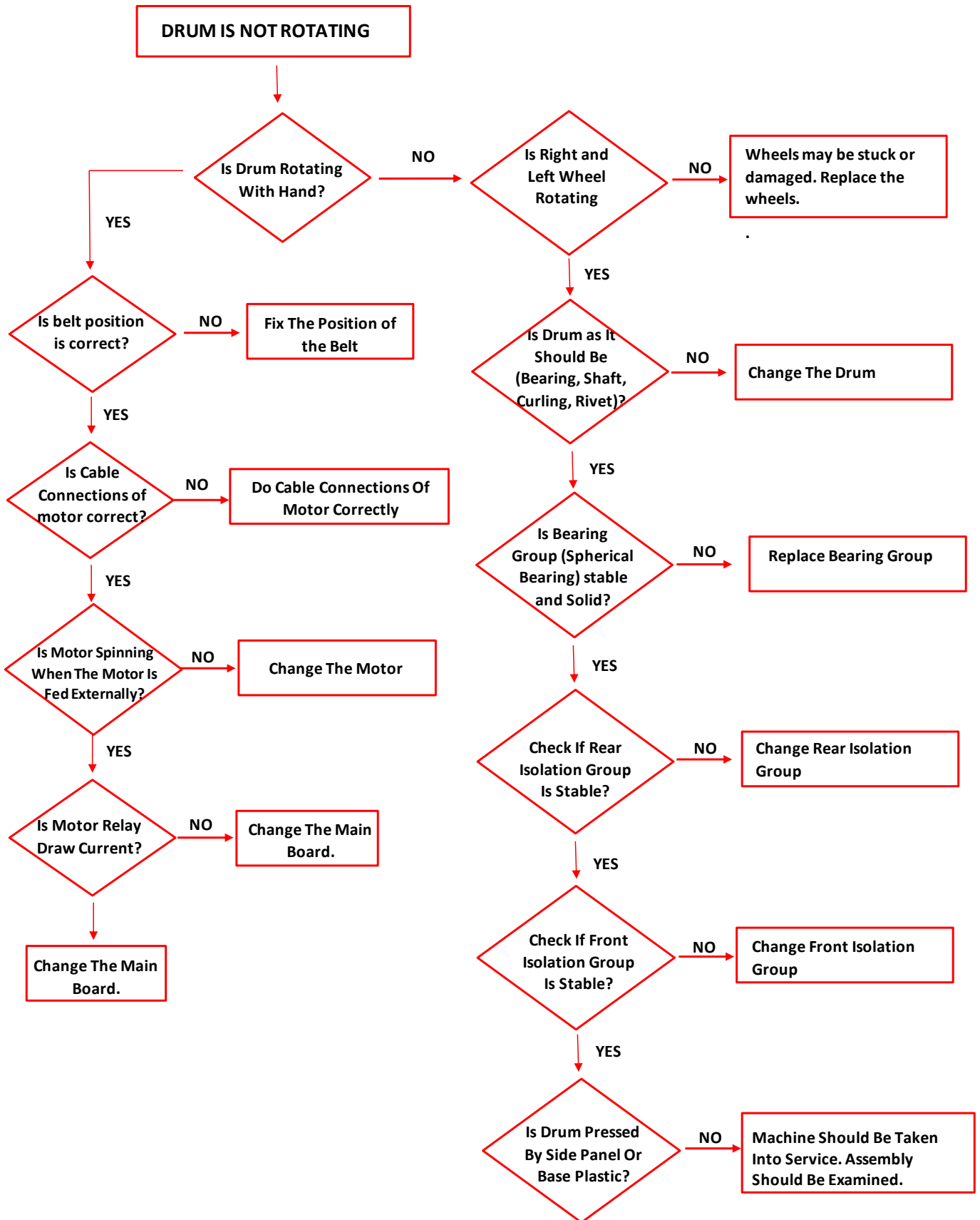



HP T3 PANEL SERVICE MANUAL

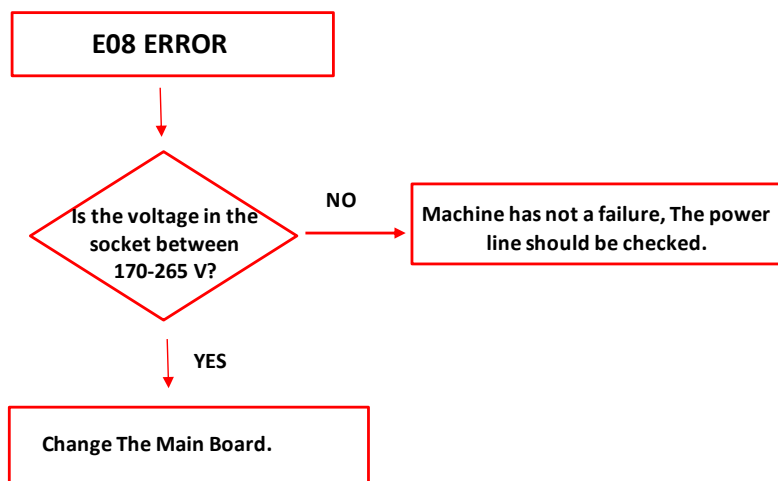
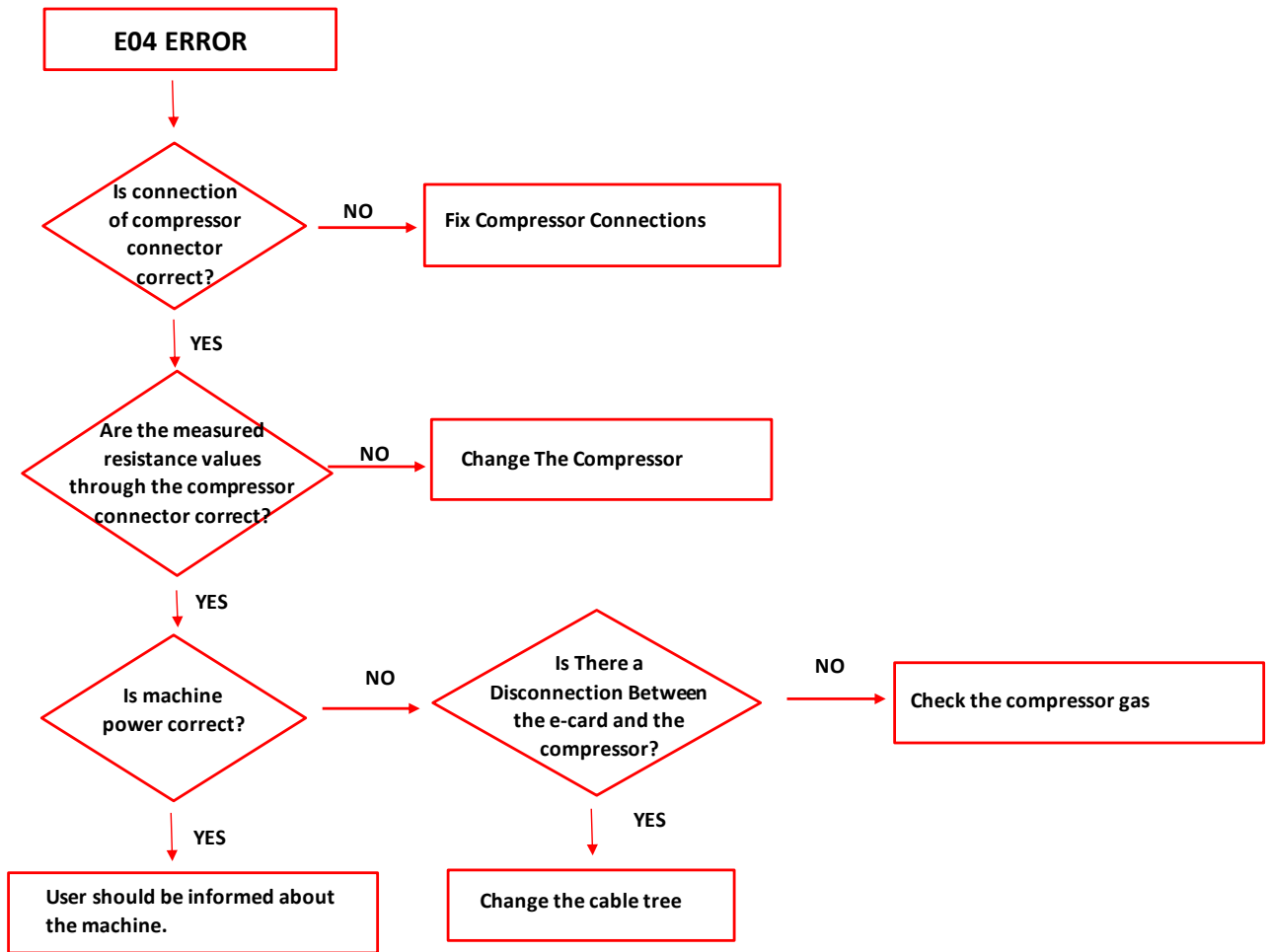



HP T3 PANEL SERVICE MANUAL

