

DISHWASHERS

SERVICE MANUAL



SERIES I

TOOLS FOR DISASSEMBLE



Phillips screwdriver

- *All kinds of star-head screws,
- *in the phillips screws of the internal components,



Plier

- *It is used to bend all kinds of sheet metal ends.



Multimeter

- *Resistance values of all kinds of internal components,
- *Electronic card resistors,
- *It is used to measure the resistance of display cards.



Flat Screwdriver

It is used to remove all kinds of aesthetic parts (side panels, front panels and external aesthetic parts of the machine).



Side Cutter

It is used to cut cables of internal components or any hard part.



Chargeable Drill

It is the most important tool used to remove and install all kinds of screws in the machine.

TABLE OF CONTENTS

1. USER INTERFACES	5
1.1 I1 SERIES W/O DISPLAY	5
1.2 I1 SERIES W DISPLAY	5
1.3 I2 SERIES W ASYNCHRONOUS MOTOR	7
1.4 I2 SERIES W BLDC MOTOR	9
1.5 I5 SERIES (TOUCH CONTROL)	11
2. WASHING PROGRAM.....	15
2.1 WASHING PROGRAM SEQUENCES	23
2.1.1 60 cm Models Program Sequences.....	23
2.1.2 45 cm Models Program Sequences.....	27
3. WASHING SPECIFICATIONS AND PROGRAMS.....	28
3.1 SELECTING AND STARTING PROGRAM AT POWER ON(BEFORE PROGRAM STARTS).....	28
3.2 OPENING AND CLOSING DOOR(BEFORE PROGRAM STARTS)	28
3.3 OPENING AND CLOSING DOOR DURING PROGRAM(NOT IN DRY STEPS).....	28
3.4 OPENING AND CLOSING DOOR DURING PROGRAM(IN DRY STEPS).....	28
3.5 OPENING AND CLOSING DOOR DURING PROGRAM(IN REGENERATION FIRST STEP)	29
3.6 TERMINATION OF A PROGRAM(END OF PROGRAM).....	29
3.7 CANCELLING OF A PROGRAM(DURING PROGRAM).....	29
3.8 SELECTING AND STARTING PROGRAM AT POWER ON WITH START DELAY	30
3.9 MODIFICATION OF A PROGRAM WITHOUT RESET	30
3.10 SWITCH OFF THE MACHINE DURING DELAY TIME	31
4. POWER FAIL.....	31
5. OPTIONS	31
5.1 OPTIONS & MODELS	31
5.2 COMPATIBILITY BETWEEN OPTIONS & PROGRAMS	33
5.3 COMPATIBILITY BETWEEN OPTIONS.....	34
5.4 OPTION DEFINITION	34
5.4.1 Delay Timer.....	35
5.4.2 Half Load.....	35
5.4.3 Extra Options	36
6. SOFTWARE REQUIREMENTS	36

6.1 HEATER	36
6.2 WATER FILL	36
6.3 WATER DRAIN.....	37
6.4 REGENERATION CYCLE	37
6.5 FEATURE OF TIME PHASE	39
6.6 VOLTAGE SENSING CONTROL	39
6.7 NTC VALUES.....	40
6.8 WATER HARDNESS SET	41
6.9 9 RINSE AID SET.....	43
6.10 INNER LIGHT	45
6.11 IONIZER.....	47
6.12 AUTOMATIC PROGRAM(TURBIDITY SENSOR).....	49
6.13 AUTODOOR OPEN SYTEM	49
6.14 AUTODOOR CONTROL TEST.....	51
6.15 BLDC MOTOR CONTROL TEST	52
6.16 VOICE CONTROL TEST	55
6.17 INFOLEDS.....	57
Infoled 1.0.....	57
Infoled 2.1 Davranışı.....	57
7. SERVICE TEST	58
7.1 SERVICE FAILURE CODES	60
8. FAILURE ROUTINES	61
8.1 DESCRIPTION OF FAILURES	62
8.2 FAILURE CODES.....	67
9. END TEST	68
9.1 End test 1.....	68
9.2 End test 2.....	69
9.3 End test 3.....	70
10. HARDWARE CONTROLS	70
10.1 BM05 TYPE MAINBOARD	70
11. MODIFICATION HISTORY OF DOCUMENT	70

1. USER INTERFACES

1.1 I1 SERIES W/O DISPLAY

I16-I15-I14-I13-I12-I11 60 cm

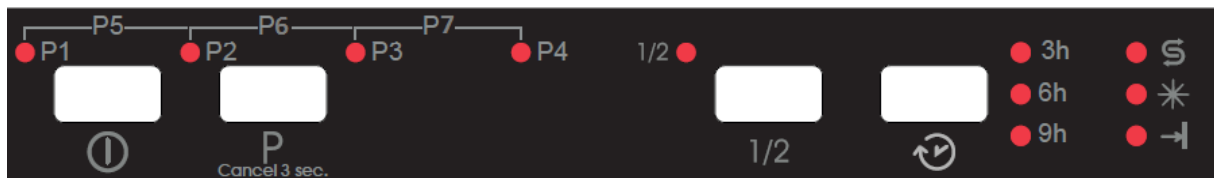

The user interface includes:

- On/Off button
- Program button with 4 leds
- Half Load button with 1 led
- Delay button (3-6-9 h)
- 3h, 6h, 9h leds
- Salt, Rinse aid, End leds

I16-I15-I14-I13-I12-I11 45 cm

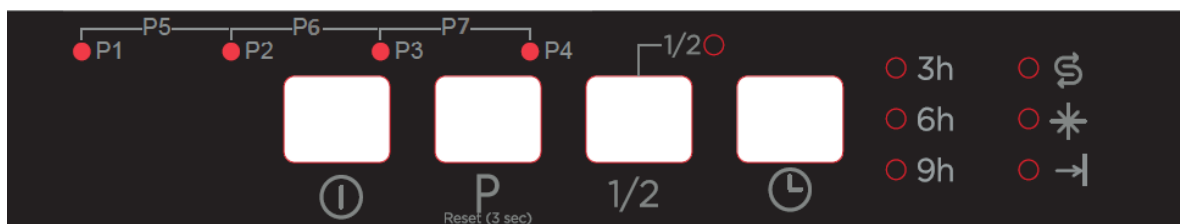

The user interface includes:

- On/Off button
- Program button with 4 leds
- Half Load button with 1 led
- Delay button with 3-6-9 h leds
- Salt, Rinse aid, End leds

I14_5 60 cm Profesyonel

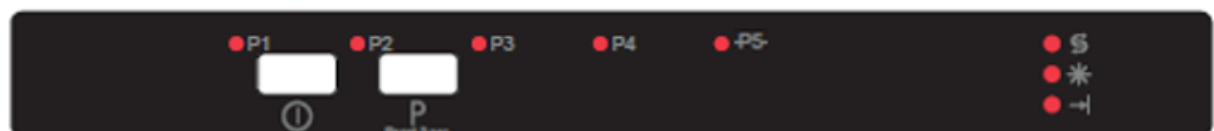

1.2 I1 SERIES W DISPLAY

I1G-I1F-I1E-I1D-I1C-I1B-I1A; I1R-I1P-I1O-I1N-I1M-I1L-I1K(with front display) 60 cm



The user interface includes:

- 188 Digit Display
- On/Off button
- Program button
- Delay button (19 h)
- Half Load button with 1/2 led
- Salt, Rinse aid leds

I1A~I1G_O; I1K~I1R_O (with front display) 60 cm with Autodoor (_O)



The user interface includes:

- 188 Digit Display
- On/Off button
- Program button
- Delay button (19 h)
- Options button with 1/2 led
- Salt, Rinse aid leds

I1G~I1F-I1E-I1D-I1C-I1B-I1A 45 cm



The user interface includes:

- 188 Digit Display
- On/Off button
- Program button
- Delay button (19 h)
- Half Load button with 1/2 led
- Salt, Rinse aid leds

1.3 3 I2 SERIES W ASYNCHRONOUS MOTOR W DIVERTER

I23-I22-I21; I2M-I2L-I2K(with front display) 60 cm



The user interface includes:

- 188 Digit Display
- On/Off button
- Program button
- Half Load button with Upper/ Lower basket leds
- Delay button (19 h)
- Options button with Hygiene and Dry leds
- Salt, Rinse aid leds

I23-I22-I21 45 cm

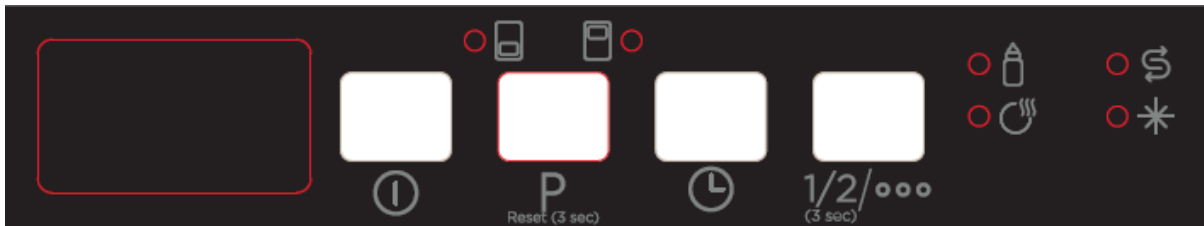

The user interface includes:

- 188 Digit Display
- On/Off button
- Program button
- Delay button (19 h)
- Half Load(3s) / Options button
- Upper / Lower basket, Hygiene, Dry leds
- Salt, Rinse aid leds

I21_5 60 cm Profesyonel

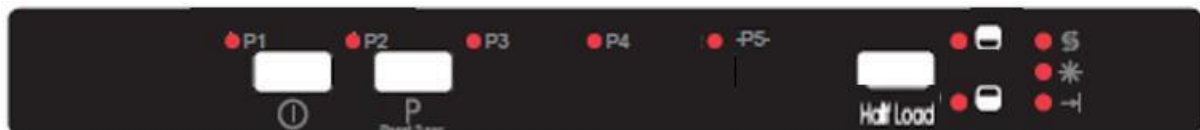

The user interface includes:

- On/Off button
- Program button
- 5 program leds
- Half Load button with Upper/ Lower basket leds
- Salt, Rinse aid, End of Program leds

I23_O-I22_O-I21_O; I2M_O-I2L_O-I2K_O(with front display) 60 cm with Autodoor



The user interface includes:

- 188 Digit Display
- On/Off button
- Program button
- Half Load button with Upper/ Lower basket leds
- Delay button (19 h)
- Options button with Energy Save, Hygiene and Dry leds
- Salt, Rinse aid leds

I22_2-I21_2 60 cm Australia Models



The user interface includes:

- 188 Digit Display
- On/Off button
- Program button
- Half Load button with Upper/ Lower basket leds
- Delay button (19 h)
- Options button with Hygiene and Dry leds
- Rinse aid led

I22_2_O-I21_2_O 60 cm Australia Models with Autodoor



The user interface includes:

- 188 Digit Display
- On/Off button
- Program button
- Half Load button with Upper/ Lower basket leds
- Delay button (19 h)
- Options button with Energy Save, Hygiene and Dry leds
- Rinse aid led

I23_2 60 cm Australia Model with Autodoor



The user interface includes:

- 188 Digit Display
- On/Off button
- Program button
- Half Load button with Upper/ Lower basket leds
- Delay button (19 h)
- Options button with Energy Save, Hygiene and Dry leds
- Rinse aid led

1.4 4 I2 SERIES W BLDC MOTOR

I24 – I2N(with front display) 60 cm



The user interface includes:

- 188 Digit Display
- On/Off button

- Program button
- Half Load button with Upper, Lower basket leds
- Delay button (19 h)
- Options button with Energy Save, Dry, Silent leds
- Salt, Rinse aid leds

I24 45 cm

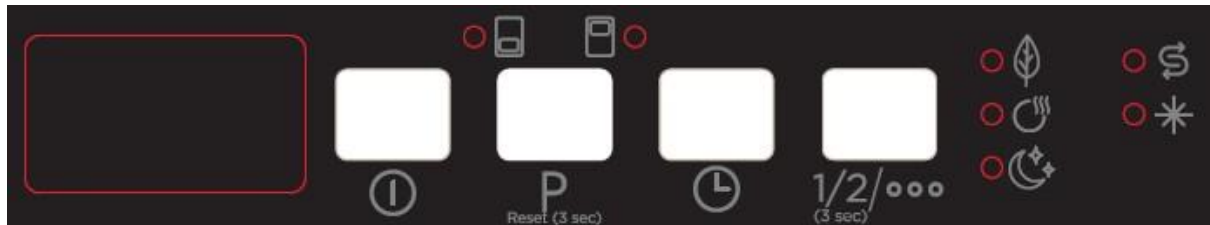

The user interface includes:

- 188 Digit Display
- On/Off button
- Program button
- Delay button (19 h)
- Half Load(3s) / Options button
- Upper / Lower basket, Energy Save, Dry, Silent leds
- Salt, Rinse aid leds

I25 – I20(with front display) 60 cm



The user interface includes:

- 188 Digit Display
- On/Off button
- Program button
- Half Load button with Upper, Lower basket leds
- Delay button (19 h)
- Options button with Energy Save, Dry, Silent leds
- Salt, Rinse aid leds

I29-I28-I27-I26; I2T-I2S-I2R-I2P(with front display) 60 cm



The user interface includes:

- 188 Digit Display
- On/Off button
- Program button
- Half Load button with Upper, Lower basket leds
- Delay button (19 h)
- Options button with Silent, Dry, Fast leds
- Salt, Rinse aid leds

I2X; I2U(with front display) 60 cm



The user interface includes:

- 188 Digit Display
- On/Off button
- Program button
- Half Load button with Upper, Lower basket leds
- Delay button (19 h)
- Options button with Silent, Dry, Fast leds
- Salt, Rinse aid leds

1.5 5 I5 SERIES (TOUCH CONTROL) W ASYNCHRONOUS MOTOR W/O DIVERTER

I51 – I51_2 (Australia) 60 cm, 45 cm



The user interface includes:

- On/Off button
- Program button
- 188 Digit Display
- Delay button(19 h) with 1 led
- Extra Dry button with 1 led
- Half Load button with 1 led

1.6 6 I5 SERIES (TOUCH CONTROL) W ASYNCHRONOUS MOTOR W DIVERTER

I53-I52 – I53_2-I52_2 (Australia) 60 cm, 45cm



The user interface includes:

- On/Off button
- Program button
- 188 Digit Display
- Delay button(19 h) with 1 led
- Dry / Rinse button with 2 leds
- Upper/Lower basket button with 2 leds

1.7 7 I5 SERIES (TOUCH CONTROL) W BLDC MOTOR

I54 - I54_2 (Australia) 60 cm, 45 cm



The user interface includes:

- On/Off button
- Program button
- 188 Digit Display
- Delay(19 h) button with 1 led
- Dry / Energy save button with 2 leds
- Upper/Lower Basket button with 2 leds
- Extra Silent / Fast button with 2 leds

I54_130 (Brilliart = One touch) 60 cm model

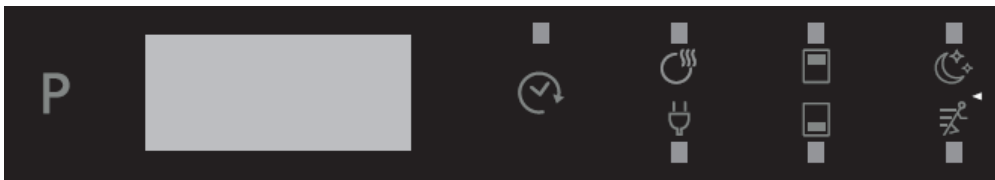

Not: Brilliart modelin üst displayinin I54 normalden tek farkı On/Off Butonunun olmamasıdır.

I54_130_UVC (Brilliart = One touch pro UVC) 60 cm model



Brilliart front display

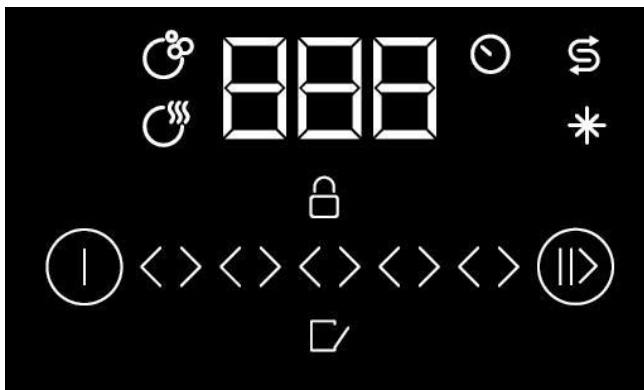

I55 60 cm



The user interface includes:

- On/Off button
- Program button
- 188 Digit Display
- Delay(19 h) button with 1 led
- Dry / Energy save button with 2 leds
- Upper/Lower Basket button with 2 leds

- Extra Silent / Fast button with 2 leds

I59, I58, I57, I56 60 cm



The user interface includes:

- On/Off button
- Program button
- 188 Digit Display
- Delay(19 h) button with 1 led
- Dry button with 1 led
- Upper/Lower Basket button with 2 leds
- Extra Silent / Fast button with 2 leds

I5X 60 cm



1.8 FRONT DISPLAY [for I1A-..I1G(I1K-.-R), I21-..I29(I2K-.-T), I14_5, I21_5 60 cm models]



- When machine is switched on and door is closed:
- At ready position, front display shows -- .
- When any program is selected, front display shows total time of the selected program.
- While program is running, front display shows remaining time of the running program as minutes, and icon led corresponding to the washing phase is on (Wash-Dry).
- If delay timer is activated, front display shows total duration of selected program / remaining delay time alternately and delay timer icon led is on.

- At the end of program front display shows **0**, and End icon led is on.
 - When half load option is selected, half mode icon led corresponding the selected basket is on. For models without diverter, only lower basket half mode icon led is on.
 - When lack of salt/rinse aid occurs, related icon led is on.
 - During drying phase, if door is opened and re-closed, the program ends, front display shows **0**, and End icon led is on.
- Note:** During regeneration and resin washing step, if the door is opened and re-closed, the program continues. Front display shows remaining time of the program, dry icon led is on.
- During cancellation of a program, front display shows **1** .

1.9 9 I54_130 (Brilliart = One touch pro) 60 cm model front display

Infoled functions continue on the top display even Brilliart (front display) exists.

Machine is off

When machine is off, all leds are off.

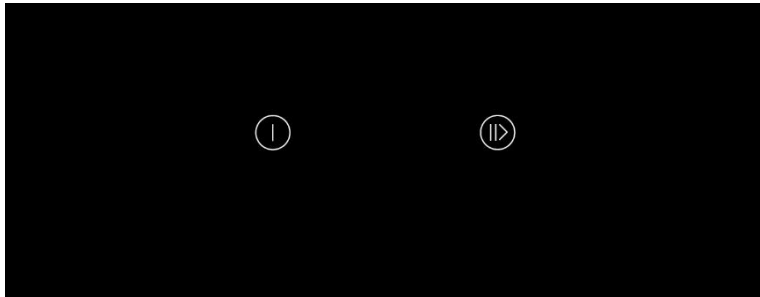

When display is fully on:

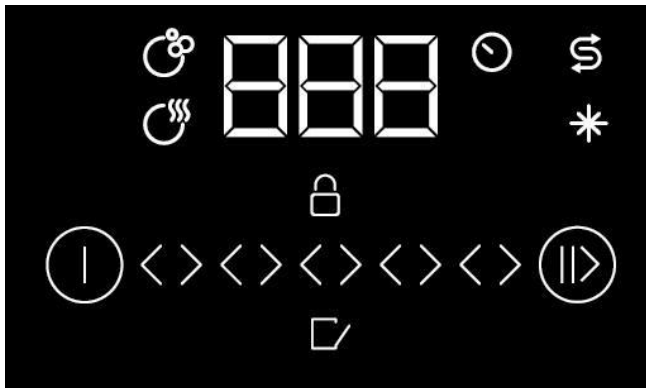

Ready position

If user turns on the machine by pressing On/Off button for 3 seconds

On/off led and Start/pause led do never turn on no matter at what position the machine is.

Arrows are on always to let user to open the door in any case.

- Program number(3sec) and program duration(1sec) are shown alternately.
- Right side arrows >>>> turn on increasingly and continuously. (when CL is enabled right and left side arrows <<<< turn on increasingly and continuously. >>>> <<<< >>>> <<<< ...)

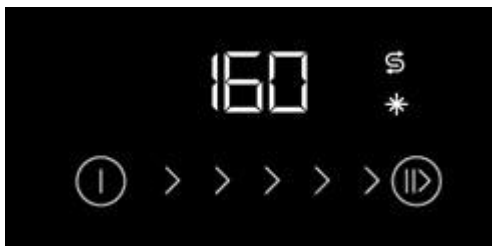
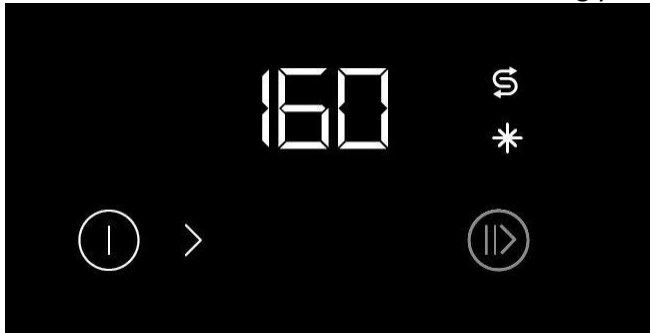

Door open

In order to open the door, user slides to the right.

- Door icon turns on.
- Arrows turns off (If CL option is enabled, white child lock icon turns on and only left side arrows turns on increasingly and continuously).



When child lock is enabled:

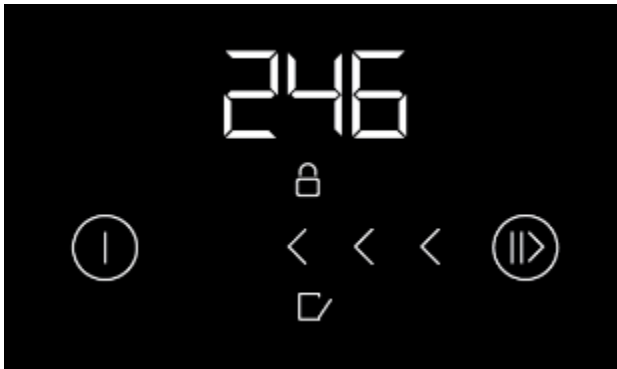

Child Lock

Child lock option is enabled by pressing ON/OFF and S/P buttons simultaneously for 3 seconds. Meanwhile, front Displays count from “3 to 1” (3-2-1) alternately with buzzer and shows “CL1” for 3 sec to indicate that child lock is enabled.

When child lock option is enabled, white child lock icon turns on, right side arrows “>>>>” turns on and then left side arrows “<<<<<” turns on increasingly and continuously.

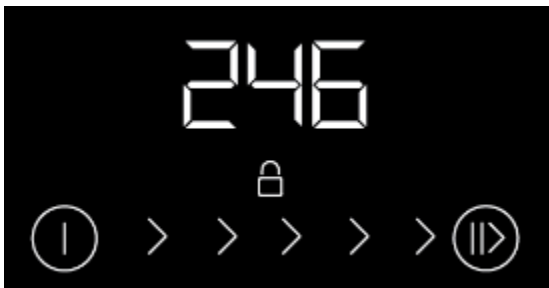



User slides to the left to activate child lock.

- Arrows turns on increasingly only to the left such as <<<<<<.
- CL is shown momentarily and red child lock icon turns on.

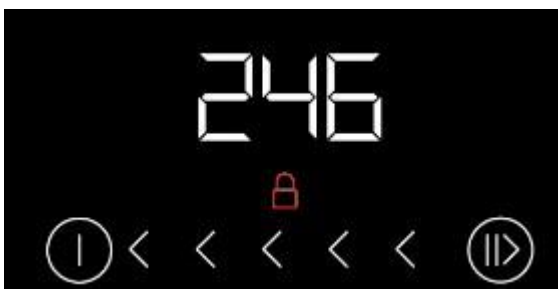

If user presses any button when child lock is on, buzzer warning is heard and CL is shown momentarily. Because of safety requirements, On/Off button is not locked. User can press On/Off to turn off/on machine when child lock is active.

User slides to the left to deactivate child lock.

- Program number (3sec) and program duration (1sec) are shown alternately.
- Right side arrows ">>>>>" turns on and then left side arrows "<<<<<" turns on increasingly and continuously.
- White child lock icon turns on.

Child lock option is disabled by pressing ON/OFF and S/P buttons simultaneously for 3 seconds. Meanwhile, front displays count from "3 to 1" (3-2-1) alternately with buzzer and then shows "CL0" to indicate that child lock is disabled.

When child lock option is disabled, white child lock icon turns off, only right side arrows “>>>>” turns on increasingly and continuously.

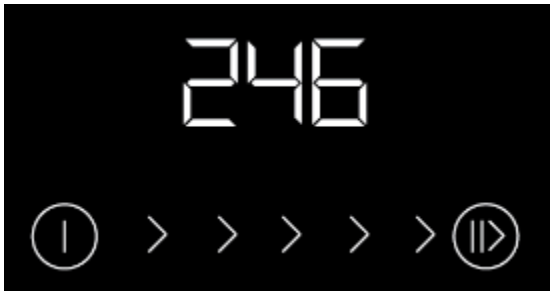

- If users switch OFF the dishwasher and switch ON again, it will remember the last selected CL level (CL0 or CL1).
- CL option can not be enabled or disabled while program is running.

In any mode (ready, run, pause, end, delay start), while the child lock is active,

- if the machine turns off and on again by on/off button, the child lock will stay active when the machine is energized. It will not be cancelled.
- if the mains power (220 V) is cut and machine is energized again, the child lock will be cancelled.

Starting a program

If user presses Start/Pause button,

- 3sec led turns on
- Wash icon turns on
- Right side arrows >>>> turn on increasingly and continuously (if CL is enabled right and left side arrows turn on increasingly and continuously. >>>> <<<< >>>> <<<< ...)
- 3 sec is shown at the bottom of Start/Pause icon.

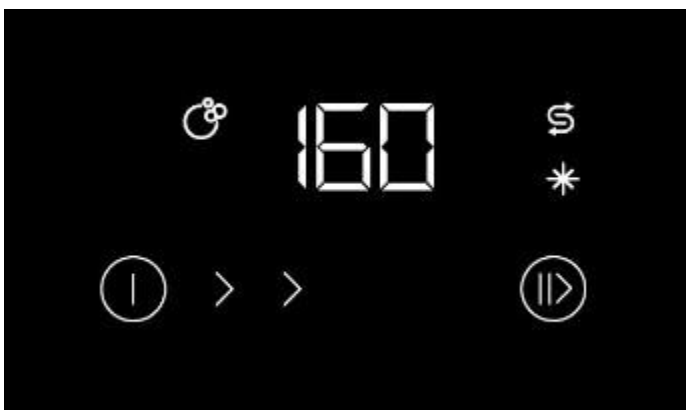

Pausing a program

If user presses Start/Pause button for 1" or opens the door while washing is executed, program pauses.

- If pausing occurs in washing, wash icon blinks on the front display. If pausing occurs in drying, dry icon blinks.
- When user presses Start/Pause button for 1", buzzer gives short sound and program pauses.
- Program duration and program number are shown alternately. (3" P number, 1" program time)
- If pausing is done by pressing Start/Pause button, right side arrows >>>> turn on increasingly and continuously (if CL is enabled right and left side arrows turn on increasingly and continuously. >>>> <<<<< >>>> <<<<< ...)
- If the door is open, arrows turns off (If CL option is enabled, white child lock icon turns on and only left side arrows turns on increasingly and continuously).

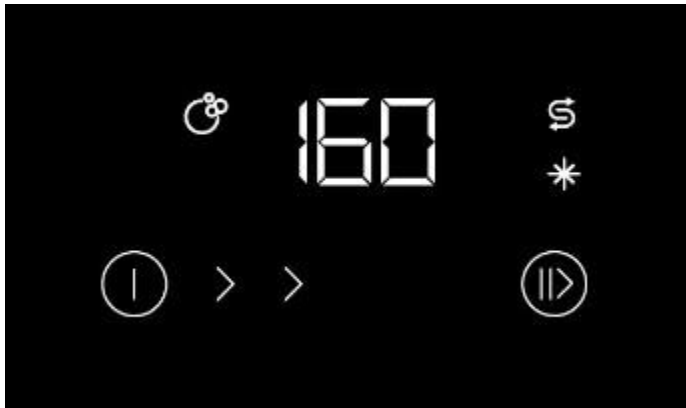

White child lock is shown on all above screens.

Cancelling a program

If user presses Start/Pause button for 3 seconds, 3-2-1 countdown with buzzer is done and at the end program is cancelled. After cancellation, display shows End.

- "1" blinks during cancellation and 3sec led becomes off
- Right side arrows >>>> turn on increasingly and continuously (if CL is enabled right and left side arrows turn on increasingly and continuously. >>>> <<<<< >>>> <<<<< ...)

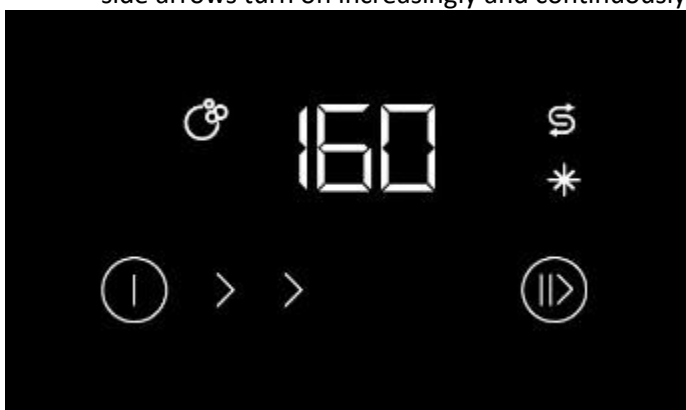

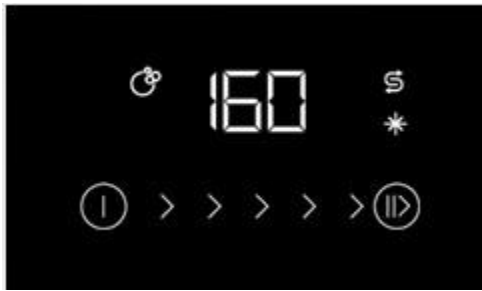

When CL is enabled:

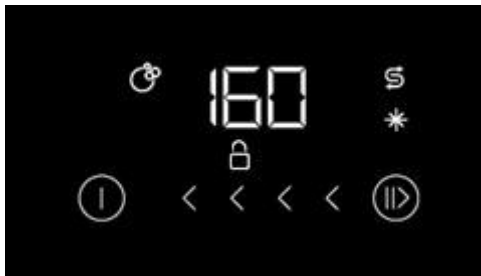

End of a program

When washing cycle is completed,

- Display shows End
- Buzzer warning is heard.
- Right side arrows >>>>> turn on increasingly and continuously (if CL is enabled right and left side arrows turn on increasingly and continuously. >>>>> <<<<< >>>>> <<<<< ...)



Delaying a program

If user selects delay time and closes the door ,

- Delay icon turns on.
- Delay starts when user presses Start/Pause button
- Delay duration and program durations are shown alternately during the delay.

- Right side arrows >>>> turn on increasingly and continuously (if CL is enabled right and left side arrows turn on increasingly and continuously. >>>> <<<< >>>> <<<< ...)
- At the end of delay, washing starts.



(CL is enabled)

Failure Situations

During failure, On/off and slide to open is available. User can both turn off/on machine and open the door.

When user opens the door during failure, buzzer warning stops.

Soft On/Off

Soft on/off is available in standby position and during washing.

When user presses On/Off button for 1 second,

- Short buzzer sound is heard. Only display becomes off, machine preserves its current situation and functional operations continues. Only On/off button can operate, sliding area and S/P cannot.
- To turn on the display, user should press On/Off button again.
- If user continues to press On/off button after 1" and hearing buzzer warning, machine turns off at the end of 3 seconds. (ex: 0.sec=press on/off, 1.sec=press on/off + short buzzer warning, 2.sec=press on/off, 3.sec=machine turns off)

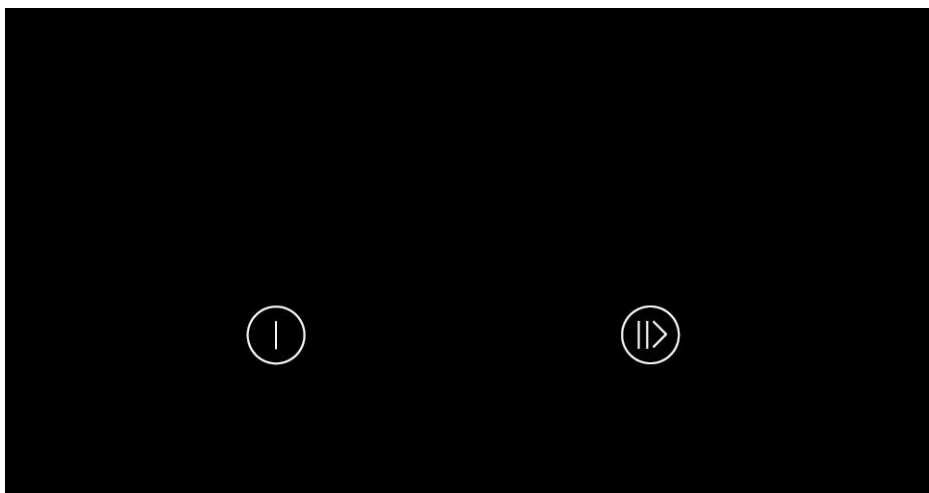

To turn off / on machine

- User should press On/Off button for 3 seconds.

If Eco mode is ON in Brilliant machine:

2. WASHING PROGRAM

2.1 WASHING PROGRAM SEQUENCES

2.1.1 60 cm Models Program Sequences

I series 60cm	Total Prg #	P1	P2	P3	P4	P5	P6	P7	P8	P9
I11	2	Eco	Intensive 65°C / Auto							
I1A	2	Eco	Intensive 65°C or Auto							
I1K	2	Eco	Intensive 65°C or Auto							
I12	3	Eco	Intensive 65°C or Auto	Super 50' 65°C						
I1B	3	Eco	Intensive 65°C or Auto	Super 50' 65°C						
I1L	3	Eco	Intensive 65°C or Auto	Super 50' 65°C						
I13	4	Eco	Intensive 65°C or Auto	Super 50' 65°C	Prewash					
I1C	4	Eco	Intensive 65°C or Auto	Super 50' 65°C	Prewash					
I1M	4	Eco	Intensive 65°C or Auto	Super 50' 65°C	Prewash					
I14	5	Eco	Intensive 65°C or Auto	Super 50' 65°C	Quick 30' 40°C	Prewash				
I1D	5	Eco	Intensive 65°C or Auto	Super 50' 65°C	Quick 30' 40°C	Prewash				

I1N	5	Eco	Intensive 65°C or Auto	Super 50' 65°C	Quick 30' 40°C	Prewash				
I15	6	Eco	Intensive 65°C or Auto	Hygiene 70°C	Super 50' 65°C	Quick 30' 40°C	Prewash			
I1E	6	Eco	Intensive 65°C or Auto	Hygiene 70°C	Super 50' 65°C	Quick 30' 40°C	Prewash			
I1O	6	Eco	Intensive 65°C or Auto	Hygiene 70°C	Super 50' 65°C	Quick 30' 40°C	Prewash			
I16	7	Eco	Intensive 65°C or Auto	Hygiene 70°C	Super 50' 65°C	Delicate 40°C	Quick 30' 40°C	Prewash		
I1F	7	Eco	Intensive 65°C or Auto	Hygiene 70°C	Super 50' 65°C	Delicate 40°C	Quick 30' 40°C	Prewash		
I1P	7	Eco	Intensive 65°C or Auto	Hygiene 70°C	Super 50' 65°C	Delicate 40°C	Quick 30' 40°C	Prewash		
I1G	8	Eco	Intensive 65°C or Auto	Hygiene 70°C	Super 50' 65°C	Easy Care 60°C	Delicate 40°C	Quick 30' 40°C	Prewash	
I1R	8	Eco	Intensive 65°C or Auto	Hygiene 70°C	Super 50' 65°C	Easy Care 60°C	Delicate 40°C	Quick 30' 40°C	Prewash	
I21	7	Eco	Intensive 65°C or Auto	Super 50' 65°C	Easy Care 60°C	Delicate 40°C	Quick 30' 40°C	Prewash		
I2K	7	Eco	Intensive 65°C or Auto	Super 50' 65°C	Easy Care 60°C	Delicate 40°C	Quick 30' 40°C	Prewash		
I22	8	Eco	Intensive 65°C or Auto	Super 50' 65°C	Easy Care 60°C	Clean+ 55°C	Delicate 40°C	Quick 30' 40°C	Prewash	
I2L	8	Eco	Intensive 65°C or Auto	Super 50' 65°C	Easy Care 60°C	Clean+ 55°C	Delicate 40°C	Quick 30' 40°C	Prewash	
I23	9	Eco	Smart 60°C - 70°C	Smart 50°C - 60°C	Smart 30°C - 50°C	Super 50' 65°C	Easy Care 60°C	Delicate 40°C	Quick 30' 40°C	Prewash
I2M	9	Eco	Smart 60°C - 70°C	Smart 50°C - 60°C	Smart 30°C - 50°C	Super 50' 65°C	Easy Care 60°C	Delicate 40°C	Quick 30' 40°C	Prewash
I26	6	Eco	Smart 60°C - 70°C	Hygiene 70°C	Super 50' 65°C	Dual Pro Wash 60°C	Quick 30' 40°C			
I2P	6	Eco	Smart 60°C - 70°C	Hygiene 70°C	Super 50' 65°C	Dual Pro Wash 60°C	Quick 30' 40°C			
I27	7	Eco	Smart 60°C - 70°C	Steam Wash	Hygiene 70°C	Super 50' 65°C	Dual Pro Wash 60°C	Quick 30' 40°C		

I2R	7	Eco	Smart 60°C - 70°C	Steam Wash	Hygiene 70°C	Super 50' 65°C	Dual Pro Wash 60°C	Quick 30' 40°C		
I28	8	Eco	Smart 60°C - 70°C	Steam Wash	Hygiene 70°C	Super 50' 65°C	Dual Pro Wash 60°C	Quick 30' 40°C	Mini 14'	
I2S	8	Eco	Smart 60°C - 70°C	Steam Wash	Hygiene 70°C	Super 50' 65°C	Dual Pro Wash 60°C	Quick 30' 40°C	Mini 14'	
I29	9	Eco	Smart 50°C - 70°C (Akışı Smart 60°C - 70°C ile aynı, sadece ismi farklı)	Smart 30°C - 50°C	Steam Wash	Hygiene 70°C	Super 50' 65°C	Dual Pro Wash 60°C	Quick 30' 40°C	Mini 14'
I2T	9	Eco	Smart 50°C - 70°C	Smart 30°C - 50°C	Steam Wash	Hygiene 70°C	Super 50' 65°C	Dual Pro Wash 60°C	Quick 30' 40°C	Mini 14'
I24	9	Eco	Smart 60°C - 70°C	Smart 50°C - 60°C	Smart 30°C - 50°C	Hygiene 70°C	Super 50' 65°C	Dual Pro Wash 60°C	Quick 30' 40°C	Mini 14'
I2N	9	Eco	Smart 60°C - 70°C	Smart 50°C - 60°C	Smart 30°C - 50°C	Hygiene 70°C	Super 50' 65°C	Dual Pro Wash 60°C	Quick 30' 40°C	Mini 14'
I25	9	Eco	Smart 50°C - 70°C (Akışı Smart 60°C - 70°C ile aynı, sadece ismi farklı)	Smart 30°C - 50°C	Hygiene 70°C	Save+ 5.4 lt	Super 50' 65°C	Dual Pro Wash 60°C	Quick 30' 40°C	Mini 14'
I20	9	Eco	Smart 50°C - 70°C	Smart 30°C - 50°C	Hygiene 70°C	Save+ 5.4 lt	Super 50' 65°C	Dual Pro Wash 60°C	Quick 30' 40°C	Mini 14'
I2X	9	Eco	Smart 50°C - 70°C (Akışı Smart 60°C - 70°C ile aynı, sadece ismi farklı)	Steam Wash	Hygiene 70°C	Save+ 5.4 lt	Super 50' 65°C	Dual Pro Wash 60°C	Quick 30' 40°C	Mini 14'
I2U	9	Eco	Smart 50°C - 70°C (Akışı Smart 60°C - 70°C ile aynı, sadece ismi farklı)	Steam Wash	Hygiene 70°C	Save+ 5.4 lt	Super 50' 65°C	Dual Pro Wash 60°C	Quick 30' 40°C	Mini 14'
I51	7	Eco	Intensive 65°C or Auto	Hygiene 70°C	Super 50' 65°C	Delicate 40°C	Quick 30' 40°C	Mini 14'		
I52	8	Eco	Intensive 65°C or Auto	Hygiene 70°C	Super 50' 65°C	Easy Care 60°C	Delicate 40°C	Quick 30' 40°C	Mini 14'	
I53	9	Eco	Smart 60°C - 70°C	Smart 50°C - 60°C	Smart 30°C - 50°C	Hygiene 70°C	Super 50' 65°C	Delicate 40°C	Quick 30' 40°C	Mini 14'
I56	6	Eco	Smart 60°C - 70°C	Hygiene 70°C	Super 50' 65°C	Dual Pro Wash 60°C	Quick 30' 40°C			
I57	7	Eco	Smart 60°C - 70°C	Steam Wash	Hygiene 70°C	Super 50' 65°C	Dual Pro Wash 60°C	Quick 30' 40°C		

I58	8	Eco	Smart 60°C - 70°C	Steam Wash	Hygiene 70°C	Super 50' 65°C	Dual Pro Wash 60°C	Quick 30' 40°C	Mini 14'	
I59	9	Eco	Smart 50°C - 70°C (Akışı Smart 60°C - 70°C ile aynı, sadece ismi farklı)	Smart 30°C - 50°C	Steam Wash	Hygiene 70°C	Super 50' 65°C	Dual Pro Wash 60°C	Quick 30' 40°C	Mini 14'
I54	9	Eco	Smart 60°C - 70°C	Smart 50°C - 60°C	Smart 30°C - 50°C	Hygiene 70°C	Super 50' 65°C	Dual Pro Wash 60°C	Quick 30' 40°C	Mini 14'
I54_130	9	Eco	Smart 50°C - 70°C	Smart 30°C - 50°C	Steam Wash	Hygiene 70°C	Super 50' 65°C	Dual Pro Wash 60°C	Quick 30' 40°C	Mini 14'
I54_130_UVC	9	Eco	Smart 60°C - 70°C	Smart 50°C - 60°C	Smart 30°C - 50°C	Steam Wash	Super 50' 65°C	Dual Pro Wash 60°C	Quick 30' 40°C	Mini 14'
I55	9	Eco	Smart 50°C - 70°C (Akışı Smart 60°C - 70°C ile aynı, sadece ismi farklı)	Smart 30°C - 50°C	Hygiene 70°C	Save+ 5.4 lt	Super 50' 65°C	Dual Pro Wash 60°C	Quick 30' 40°C	Mini 14'
I5X	9	Eco	Smart 50°C - 70°C (Akışı Smart 60°C - 70°C ile aynı, sadece ismi farklı)	Steam Wash	Hygiene 70°C	Save+ 5.4 lt	Super 50' 65°C	Dual Pro Wash 60°C	Quick 30' 40°C	Mini 14'

Profesyonel product	I14_5		I21_5	
	I1D_5			
	I1N_5		I2K_5	
	EN	TR	EN	TR
P1	Eco	Eko	Eco	Eko
P2	Super 49'	Super 49'	Super 49'	Super 49'
P3	Glass 29'	Kirli Bardak 29'	Glass 29'	Kirli Bardak 29'

P4	Fast Glass 19'	Az Kirli Bardak 19'	Fast Glass 19'	Az Kirli Bardak 19'
P5	Jet Glass 14'	Hızlı Durulama 14'	Jet Glass 14'	Hızlı Durulama 14'

2.1.2 45 cm Models Program Sequences

I series 45cm	Total Programs #	P1	P2	P3	P4	P5	P6	P7	P8	P9
I11	2	Eco	Intensive 65°C / Auto							
I1A	2	Eco	Intensive 65°C or Auto							
I12	3	Eco	Intensive 65°C or Auto	Super 50' 65°C						
I1B	3	Eco	Intensive 65°C or Auto	Super 50' 65°C						
I13	4	Eco	Intensive 65°C or Auto	Super 50' 65°C	Prewash					
I1C	4	Eco	Intensive 65°C or Auto	Super 50' 65°C	Prewash					
I14	5	Eco	Intensive 65°C or Auto	Super 50' 65°C	Quick 30' 40°C	Prewash				
I1D	5	Eco	Intensive 65°C or Auto	Super 50' 65°C	Quick 30' 40°C	Prewash				
I15	6	Eco	Intensive 65°C or Auto	Hygiene 70°C	Super 50' 65°C	Quick 30' 40°C	Prewash			
I1E	6	Eco	Intensive 65°C or Auto	Hygiene 70°C	Super 50' 65°C	Quick 30' 40°C	Prewash			
I16	7	Eco	Intensive 65°C or Auto	Hygiene 70°C	Super 50' 65°C	Delicate 40°C	Quick 30' 40°C	Prewash		
I1F	7	Eco	Intensive 65°C or Auto	Hygiene 70°C	Super 50' 65°C	Delicate 40°C	Quick 30' 40°C	Prewash		
I1G	8	Eco	Intensive 65°C or Auto	Hygiene 70°C	Super 50' 65°C	Easy Care 60°C	Delicate 40°C	Quick 30' 40°C	Prewash	
I21	7	Eco	Intensive 65°C or Auto	Super 50' 65°C	Easy Care 60°C	Delicate 40°C	Quick 30' 40°C	Prewash		
I22	8	Eco	Intensive 65°C or Auto	Super 50' 65°C	Easy Care 60°C	Clean+ 55°C	Delicate 40°C	Quick 30' 40°C	Prewash	
I23	9	Eco	Smart 60°C - 70°C	Smart 50°C - 60°C	Smart 30°C - 50°C	Super 50' 65°C	Easy Care 60°C	Delicate 40°C	Quick 30' 40°C	Prewash
I24	9	Eco	Smart 60°C - 70°C	Smart 50°C - 60°C	Smart 30°C - 50°C	Hygiene 70°C	Super 50' 65°C	Dual Pro Wash 60°C	Quick 30' 40°C	Mini 14'
I51	7	Eco	Intensive 65°C or Auto	Hygiene 70°C	Super 50' 65°C	Delicate 40°C	Quick 30' 40°C	Mini 14'		
I52	8	Eco	Intensive 65°C or Auto	Hygiene 70°C	Super 50' 65°C	Easy Care 60°C	Delicate 40°C	Quick 30' 40°C	Mini 14'	
I53	9	Eco	Smart 60°C - 70°C	Smart 50°C - 60°C	Smart 30°C - 50°C	Hygiene 70°C	Super 50' 65°C	Delicate 40°C	Quick 30' 40°C	Mini 14'

I54	9	Eco	Smart 60°C - 70°C	Smart 50°C - 60°C	Smart 30°C - 50°C	Hygiene 70°C	Super 50' 65°C	Dual Pro Wash 60°C	Quick 30' 40°C	Mini 14'
------------	---	-----	-------------------	-------------------	-------------------	--------------	----------------	--------------------	----------------	----------

3. WASHING SPECIFICATIONS AND PROGRAMS

3.1 SELECTING AND STARTING PROGRAM AT POWER ON(BEFORE PROGRAM STARTS)

COMMANDS	Top Display	Flow ind.	Front display	End icon
Switch on	--	OFF	None	OFF
Select program	Duration of program / Program number	OFF	None	OFF
Door closed	None	Washing icon ON	Duration of program	OFF

Note: When machine is switched on, 3 short beeps are heard. When it is turned off, buzzer gives long sound.

3.2 OPENING AND CLOSING DOOR(BEFORE PROGRAM STARTS)

COMMANDS	Top Display	Flow ind.	Front display	End icon
Door open	--	OFF	None	OFF
Door closed	None	OFF	--	OFF

3.3 OPENING AND CLOSING DOOR DURING PROGRAM(NOT IN DRY STEPS)

During the program if the door is opened and re-closed without any modifications on the program button the program continues. Washing program re-starts after 8" if the measured temperature is equal or more than 45°C.

COMMANDS	Top Display	Flow ind.	Front display	End icon
Door open	Duration of program / Program number	None	None	OFF
Door closed	None	ON	Duration of program	OFF

3.4 OPENING AND CLOSING DOOR DURING PROGRAM (IN DRY STEPS)

For I1, I2 models, during dry step: if the door is opened and re-closed, the program ends.

COMMANDS	Top Display	Flow ind.	Front display	End
Door open	Duration of program / Program number	None	None	OFF
Door closed	None	End icon ON	"0"	ON

For I5 models, during drying step: if the door is opened and closed or program is paused and started or machine is off-on, the program continuous from the remaining step of the drying.

3.5 OPENING AND CLOSING DOOR DURING PROGRAM(IN REGENERATION FIRST STEP)

During regeneration and resin washing step: if the door is opened and re-closed, the program continues.

COMMANDS	Top Display	Flow ind.	Front display	End
Door open	Duration of program / Program number	None	None	OFF
Door closed	None	Dry icon ON	Duration of program	OFF

3.6 TERMINATION OF A PROGRAM(END OF PROGRAM)

COMMANDS	Top Display	Flow ind.	Front display	End
Door open	"0"	None	None	ON
Door closed	None	End icon ON	"0"	ON

- When the program is completed, End led will be on and the buzzer will be activated (1sec sound, 4sec wait untill total time 21sec is completed [total 5 bip sound]) If the door is not opened by the user the activation of the buzzer will continue until 15 min passed which means that in first 5min : (1sec sound + 4sec wait) x5) signal / In the second 5min: (1sec sound + 4sec wait) x5) signals and in the last 5min: (1sec sound + 4sec wait)x5) signals, then the routine is stopped.
- If there is no user intervention during 15 minutes after program has ended, machine turns off automatically, and switch off buzzer is activated.

3.7 7 CANCELLING OF A PROGRAM(DURING PROGRAM)

COMMANDS	Top Display	Flow ind.	Front display	End
Door open	Duration of program / Program number	None	None	OFF
Press 3" program button	Duration of program / Program number	None	None	OFF
At the end of the 3"	" 1"	None	None	Blink
Door closed	" 1"	Dry icon ON	" 1"	OFF
During canceling	" 1"	Dry icon ON	" 1"	OFF
At the end of the canceling	"0"	End icon ON	"0"	ON

3.8 SELECTING AND STARTING PROGRAM AT POWER ON WITH START DELAY

COMMANDS	Top Display	Flow ind.	Front display	End
Switch on	--	OFF	--	OFF
Select program	Duration of program / Program number	None	None	OFF
Select delay (press delay button)	Duration of program / Program number / Delay time	None	None	OFF
Door closed	None	OFF	Duration of program / Delay time / Delay icon is ON	OFF
During the delay time	None	OFF	Duration of program / Delay time / Delay icon is ON	OFF
End of delay time	None	Washing icon ON	Duration of program	OFF

3.9 MODIFICATION OF A PROGRAM WITHOUT RESET

The program continues with the flow program but with the parameters (temperature, times) of the new program. In heating step: If temperature is over than the new desired temperature, cut off heating step and go on with the next step with new parameters.

If temperature is lower than the new desired temperature heat up water to the desired temperature level.

In washing step: If the washing duration is over than the washing duration of new program, cut off washing step and go on with next step of new program.

If the washing duration is lower than the washing duration of new program, go on with washing step.

When new program is selected, display duration is changed to same step of new program.

COMMANDS	Top Display	Flow ind.	Front display	End
Washing cycle is in progress	None	ON	Duration of program	OFF
Door open	Duration of program / Program number	None	None	OFF
Select new program	Duration of new program / Program number	None	None	OFF
Door closed	None	ON	Duration of new program	OFF

3.10 MODIFICATION OF A PROGRAM DURING DELAY TIME

- While delay timer is selected but not started or started and paused, if any program button is pressed, delay timer is cancelled and machine goes to ready state.

3.11 SWITCH OFF THE MACHINE DURING DELAY TIME

- While delay timer is active, If machine switch off and on by ON/OFF button, delay timer is cancelled and machine goes to ready position.
- If mains power off-on occurs (power cut); delay time resumes, does not start again.

4 POWER FAIL

- **During a Delay Start:** At the power on, program consumes the remaining time.
- **During a Drain + Fill step:** At the power on the program restarts the step to the beginning (with the drain).
- **During a Wash step:** At the power on the program consumes the remaining time.
- **During a Heating step:** At the power on the program continues heating up to the desired temperature. The time out for the heating restart to the beginning (water could be cold again).
- **During a Dry step:** At the power on the program ends.
- **During the first two step of a salt regeneration cycle (60" REGVALVE = ON or 60" REGVALVE+DRAIN ON):** At the power on washing program will continue.
- **During the washing resin step at regeneration cycle:** At the power on the program ends.

It is possible that the power fail occurred when a regeneration cycle is requested. If it occurs:

- During the first two step of a salt regeneration cycle (60" REGVALVE = ON or 60" REGVALVE+DRAIN ON): at the power on washing program will continue.

- After the first two step of a salt regeneration cycle: at the power on the washing program will end and the resin wash will be performed at the beginning of the next washing cycle.

After a Power Fail washing program re-starts without any delay if temp. is less than 45° C.

After a Power Fail washing program **wait 8"** before re-starts program if temp. is equal or more than 45° C.

5 OPTIONS

5.10 OPTIONS & MODELS

Model	Size	Motor Type	Electrical Diverter	Delay timer option		Half load		Extra Hygiene	Extra Rinse	Extra Drying	Extra Silent	Extra Fast	Energy Save
				3,6,9hr	1-2-...-19hr	1 mode	3 modes						
I11	60cm	Async.	-	Yes	-	Yes	-	-	-	-	-	-	-
I1A	60cm	Async.	-	-	Yes	Yes	-	-	-	-	-	-	-
I1K	60cm	Async.	-	-	Yes	Yes	-	-	-	-	-	-	-
I12	60cm	Async.	-	Yes	-	Yes	-	-	-	-	-	-	-
I1B	60cm	Async.	-	-	Yes	Yes	-	-	-	-	-	-	-
I1L	60cm	Async.	-	-	Yes	Yes	-	-	-	-	-	-	-

I13	60cm	Async.	-	Yes	-	Yes	-	-	-	-	-	-	-
I1C	60cm	Async.	-	-	Yes	Yes	-	-	-	-	-	-	-
I1M	60cm	Async.	-	-	Yes	Yes	-	-	-	-	-	-	-
I14	60cm	Async.	-	Yes	-	Yes	-	-	-	-	-	-	-
I1D	60cm	Async.	-	-	Yes	Yes	-	-	-	-	-	-	-
I1N	60cm	Async.	-	-	Yes	Yes	-	-	-	-	-	-	-
I15	60cm	Async.	-	Yes	-	Yes	-	-	-	-	-	-	-
I1E	60cm	Async.	-	-	Yes	Yes	-	-	-	-	-	-	-
I1O	60cm	Async.	-	-	Yes	Yes	-	-	-	-	-	-	-
I16	60cm	Async.	-	Yes	-	Yes	-	-	-	-	-	-	-
I1F	60cm	Async.	-	-	Yes	Yes	-	-	-	-	-	-	-
I1P	60cm	Async.	-	-	Yes	Yes	-	-	-	-	-	-	-
I1G	60cm	Async.	-	-	Yes	Yes	-	-	-	-	-	-	-
I1R	60cm	Async.	-	-	Yes	Yes	-	-	-	-	-	-	-
I21 - I21_2	60cm	Async.	Yes	-	Yes	-	Yes	Yes	-	Yes	-	-	-
I2K	60cm	Async.	Yes	-	Yes	-	Yes	Yes	-	Yes	-	-	-
I21_2_O	60cm	Async.	Yes	-	Yes	-	Yes	Yes	-	Yes	-	-	Yes
I22- I22_2	60cm	Async.	Yes	-	Yes	-	Yes	Yes	-	Yes	-	-	-
I2L	60cm	Async.	Yes	-	Yes	-	Yes	Yes	-	Yes	-	-	-
I22_2_O	60cm	Async.	Yes	-	Yes	-	Yes	Yes	-	Yes	-	-	Yes
I23	60cm	Async.	Yes	-	Yes	-	Yes	Yes	-	Yes	-	-	-
I2M	60cm	Async.	Yes	-	Yes	-	Yes	Yes	-	Yes	-	-	-
I23_2	60cm	Async.	Yes	-	Yes	-	Yes	Yes	-	Yes	-	-	Yes
I26	60cm	BLDC	Yes	-	Yes	-	Yes	-	-	Yes	Yes	Yes	-
I2P	60cm	BLDC	Yes	-	Yes	-	Yes	-	-	Yes	Yes	Yes	-
I27	60cm	BLDC	Yes	-	Yes	-	Yes	-	-	Yes	Yes	Yes	-
I2R	60cm	BLDC	Yes	-	Yes	-	Yes	-	-	Yes	Yes	Yes	-
I28	60cm	BLDC	Yes	-	Yes	-	Yes	-	-	Yes	Yes	Yes	-
I2S	60cm	BLDC	Yes	-	Yes	-	Yes	-	-	Yes	Yes	Yes	-
I29	60cm	BLDC	Yes	-	Yes	-	Yes	-	-	Yes	Yes	Yes	-
I2T	60cm	BLDC	Yes	-	Yes	-	Yes	-	-	Yes	Yes	Yes	-
I24	60cm	BLDC	Yes	-	Yes	-	Yes	-	-	Yes	Yes	-	Yes
I2N	60cm	BLDC	Yes	-	Yes	-	Yes	-	-	Yes	Yes	-	Yes
I25	60cm	BLDC	Yes	-	Yes	-	Yes	-	-	Yes	Yes	-	Yes
I2O	60cm	BLDC	Yes	-	Yes	-	Yes	-	-	Yes	Yes	-	Yes
I2X	60cm	BLDC	Yes	-	Yes	-	Yes	-	-	Yes	Yes	Yes	-
I2U	60cm	BLDC	Yes	-	Yes	-	Yes	-	-	Yes	Yes	Yes	-
I51-I51_2	60cm	Async.	-	-	Yes	Yes	-	-	-	Yes	-	-	-
I52-I52_2	60cm	Async.	Yes	-	Yes	-	Yes	-	Yes	Yes	-	-	-
I53-I53_2	60cm	Async.	Yes	-	Yes	-	Yes	-	Yes	Yes	-	-	-

I56	60cm	BLDC	Yes	-	Yes	-	Yes	-	-	Yes	Yes	Yes	-
I57	60cm	BLDC	Yes	-	Yes	-	Yes	-	-	Yes	Yes	Yes	-
I58	60cm	BLDC	Yes	-	Yes	-	Yes	-	-	Yes	Yes	Yes	-
I59	60cm	BLDC	Yes	-	Yes	-	Yes	-	-	Yes	Yes	Yes	-
I5X	60cm	BLDC	Yes	-	Yes	-	Yes	-	-	Yes	Yes	Yes	-
I54-I54_2	60cm	BLDC	Yes	-	Yes	-	Yes	-	-	Yes	Yes	Yes	Yes
I54_130	60cm	BLDC	Yes	-	Yes	-	Yes	-	-	Yes	Yes	Yes	Yes
I54_130_UVC	60cm	BLDC	Yes	-	Yes	-	Yes	Yes	-	Yes	Yes	-	Yes
I55	60cm	BLDC	Yes	-	Yes	-	Yes	-	-	Yes	Yes	Yes	Yes
I11	45cm	Async.	-	Yes	-	Yes	-	-	-	-	-	-	-
I1A	45cm	Async.	-	-	Yes	Yes	-	-	-	-	-	-	-
I12	45cm	Async.	-	Yes	-	Yes	-	-	-	-	-	-	-
I1B	45cm	Async.	-	-	Yes	Yes	-	-	-	-	-	-	-
I13	45cm	Async.	-	Yes	-	Yes	-	-	-	-	-	-	-
I1C	45cm	Async.	-	-	Yes	Yes	-	-	-	-	-	-	-
I14	45cm	Async.	-	Yes	-	Yes	-	-	-	-	-	-	-
I1D	45cm	Async.	-	-	Yes	Yes	-	-	-	-	-	-	-
I15	45cm	Async.	-	Yes	-	Yes	-	-	-	-	-	-	-
I1E	45cm	Async.	-	-	Yes	Yes	-	-	-	-	-	-	-
I16	45cm	Async.	-	Yes	-	Yes	-	-	-	-	-	-	-
I1F	45cm	Async.	-	-	Yes	Yes	-	-	-	-	-	-	-
I1G	45cm	Async.	-	-	Yes	Yes	-	-	-	-	-	-	-
I21	45cm	Async.	Yes	-	Yes	-	Yes	Yes	-	Yes	-	-	-
I22	45cm	Async.	Yes	-	Yes	-	Yes	Yes	-	Yes	-	-	-
I23	45cm	Async.	Yes	-	Yes	-	Yes	Yes	-	Yes	-	-	-
I24	45cm	BLDC	Yes	-	Yes	-	Yes	-	-	Yes	Yes	-	Yes
I51	45cm	Async.	-	-	Yes	Yes	-	-	-	Yes	-	-	-
I52	45cm	Async.	Yes	-	Yes	-	Yes	-	Yes	Yes	-	-	-
I53	45cm	Async.	Yes	-	Yes	-	Yes	-	Yes	Yes	-	-	-
I54	45cm	BLDC	Yes	-	Yes	-	Yes	-	-	Yes	Yes	Yes	Yes

5.11 COMPATIBILITY BETWEEN OPTIONS & PROGRAMS

I Series	Programs vs. Options							
	Energy Save	Extra Fast	Half Load	Triple & Direct	Extra Silent	Ext Dry	Ext Hygiene	Ext Rinse
Eco	OK	OK	OK	OK	OK	OK	OK	OK
Smart Programs	OK		OK	OK		OK	OK	OK
Intensive / Auto	OK		OK	OK		OK	OK	OK
Hygiene	OK		OK	OK		OK		OK

Steam Wash	OK		OK	OK		OK	OK	OK
Save+ 5.4 lt	OK	OK	OK	OK	OK	OK	OK	OK
Dual Prowash	OK	OK	OK	OK	OK	OK	OK	OK
Delicate	OK		OK	OK		OK	OK	OK
Easy Care	OK		OK	OK		OK	OK	OK
Super	OK		OK	OK		OK	OK	OK
Quick	OK		OK	OK		OK	OK	OK
Mini 14'	OK		OK					
Prewash			OK	OK				

5.12 COMPATIBILITY BETWEEN OPTIONS

Options	Energy Save	Extra Fast	Half Load	Triple & Direct	Extra Silent	Extra Dry	Ext Hygiene	Extra Rinse
Energy Save		OK	OK	OK	OK	OK	OK	OK
Extra Fast	OK		OK	OK		OK		
Half Load	OK	OK			OK	OK	OK	OK
Triple & Direct	OK	OK			OK	OK	OK	OK
Extra Silent	OK		OK	OK		OK		
Extra Dry	OK	OK	OK	OK	OK			OK
Ext Hygiene	OK		OK	OK				OK
Extra Rinse	OK		OK	OK		OK	OK	

5.4 OPTION DEFINITION

Option	Short description
Delay Timer	Program starts with a delay
Half Load(3 modes)	The wash is executed with upper spray, lower spray or both in half load mode.
Energy Save	At the end of the drying process, the dishwasher door automatically opens to allow steam to escape and cool air to circulate. (Sadece programa ilk start verilmeden seçilebilir.)

Extra Fast	Reduces the duration of the washing. (Sadece programa ilk start verilmeden seçilebilir.)
Extra Silent	Reduces the sound pressure level of the washing. (Sadece programa ilk start verilmeden seçilebilir.)
Extra Hygiene	Increase the washing temperature at final rinse step in order to eliminate bacteria
Extra Dry	This option increases water temperature at final rinse step and increase drying step duration up to 10 min.
Extra Rinse	Extra rinse option adds an extra rinse step to achieve more hygienic washing. Programme duration is increased between min. %4 and max. %16 according to washing programme

5.4.1 Delay Timer

The delay timer option is selected by pressing the regarding option button before the program starts. It is possible to select the delay before selecting the program.

Before program is started, all indicator leds and delay leds are OFF.

Before starting the program,

- Delay is selected by consecutive pressures of the button. The required delay value is chosen
- At each pressure, the display shows one step of increment (from 1h to 19h); having been reaching its maximum value (19h)
- The next pressure clears the delay and shows "0h".
- Before closing the door, selected program and delay durations are shown on the display alternately in 2" interval.
- After closing the door, the program with delay will be in operation.

Cancelling the delay start is possible during the delay time.

- Open the door
- Press the delay button, until the delay time is "0h"
- Press Start/Start button and the washing program will start.

- **When delay timer is selected, if machine switch off and on by ON/OFF button, delay timer is cancelled and machine goes to ready state.**
- **If mains power off-on occurs (power cut); delay time resumes, does not start again.**
- **When delay timer is selected but not started or started and paused, if any program button is pressed, delay timer is cancelled and machine goes to ready state.**

5.4.2 Half Load

The wash is executed with upper spray, Lower spray or both in half load mode.

Half Load option is selected at any time (during program or before starting program) by pressing the regarding option button.

First Press: Upper spray led is ON and lower spray led is OFF. Wash is executed only with upper spray arm.

Second Press: upper spray led is OFF and lower spray led is ON. Wash is executed only with lower spray arm.

Third Press: Upper spray led is ON and lower spray led is ON → Half Load washing.

Fourth Press: Upper spray led is OFF and lower spray led is OFF → Normal washing.

If user presses half load button for 1,8", Energy save option is activated and its led becomes on. This option can be deactivated by pressing half load button for 1,8" again.

5.4.3 xtra Options

Extra option is selected before program start by pressing "Option" button and regarding led is ON.

When Option button is pressed;

First time: Extra Fast led is ON, Extra Silent led is OFF. Wash is executed with the following steps with "Fast" functions instead of the normal.

Second time: Extra Silent led is ON, Extra Fast led is OFF. Wash is executed with the following steps with "Silent" functions instead of the normal.

Last time: Extra Fast and Silent leds are OFF. Normal wash is executed.

Note: Fast and Silent options cannot be selected together.

6 SOFTWARE REQUIREMENTS

6.1 HEATER

Heating relay must be switched with un-supplied Heater.

- Stop Circulation Pump.
- Wait for pressure switch certainly open.
- Open/Close Heater Relay
- Wait (Heater relay certainly close);
- Start Circulation Pump.

If Tablet is selected, heating steps must be < 55°C for steps before last rinse.

Note: On commercial models (I14_5, I21_5), NTC temperature measurements will be 60"+300". On the other models it will be 120"+300".

6.2 WATER FILL

Water Load is obtained by flow meter signals. When a fixed quantity of water is loaded, the reaching water level is checked by the activation of circulation pump. When the pressure is high enough, the pressure switch is activated.

For 1L water inlet, MCU must detect 210 Pulse/L (with +-5% tolerance) from flowmeter .

At the start program a drain 30" + empty is executed before fill.

When Inlet valve is ON, if there aren't flow meter impulses, failure routine of "absence of flow meter impulses routine" works (see on failure chapter).

If pressure sensing switch turns OFF during the wash, after a drain +20", another water load is executed (also see "return empty level" failure in failure chapter).

Water fill must work;

- Pressure > 0,8l: all OK
- 0,3<pressure<0,8l:OKwith time out
- Pressure< 0,3l: stop cycle.

Water fill is performed spray arms start.

6.3 WATER DRAIN

Water drain starts with drain pump ON for 33". After 30", circulation pump ON. When empty level is recognized (by pressure switch signal), the circulation pump stops and the machine continues for the request steps.

If pressure switch level doesn't switch in Empty level (during circulation pump on), failure of Water drain works (see 8.failure routines).

Water drain is performed with lower spray arm

Detergent dispenser step

After wash+heating step is started 3 seconds, Dispenser is activated during 5 seconds. If power fail or opening door or pushing Start/Stop or switching OFF is happened, Detergent dispenser step is started again.

Note: For the detergent step 2' of upper spray arm are performed.

Rinse aid dispenser step

Dispenser is activated 25 seconds during rinse aid dispenser step twice. There is 5 seconds between two activation. If power fail or opening door or pushing Start/Stop or switching OFF is happened, Dispenser is activated one more time 25 seconds

If the door is opened and re-closed during washing program, without a re-start program, detergent dispenser must return in Rinse aid distribution state.

Y2: for the rinse aid step 2' of upper spray arm is performed.

6.4 REGENERATION CYCLE

When it occurs the regeneration valve works after last rinse and during the drying steps. There are 6 hardness levels.

Water Hardness level	Litres
Level 1	Never
Level 2	116 lt
Level 3	64 lt
Level 4	52 lt
Level 5	46 lt
Level 6	16 lt

The consumed liters are counted by flow meter impulses.

In case of flow meter broken, the liters corresponding at the flow meter time out are used

If user cancels a program during regeneration or after regeneration and before resin wash, at the beginning of the next program the dishwasher performs the resin wash to remove the salty water from

the resin chamber. The resin wash will be: load 2 lt of water with drain pump on. During the resin wash the circulation Pump must be off.

Regeneration is not performed at prewash program

If water hardness level is changed from lower to higher, regeneration cycle is performed at the end of the first program

If water hardness level is changed from higher to lower, regeneration cycle is not performed at the end of the first program. Regeneration is performed after water level reach to value of level

- If Water hardness level is 5 or 6
 - First regeneration step is performed 0,2lt water
- If Water hardness level is 2 or 3 or 4
 - First regeneration step is performed 0,1lt water
- If Water hardness level is 1
 - Regeneration step is not performed

-The consumed liters are counted by FLM(flow meter) impulses.

-In case of FLM broken, the liters corresponding at the FLM time out are used. (2,1 lt + 2,5 lt).

-In case of "Tablet" option is ON;

- *If the level set is less than L4: the regeneration cycle is not performed, but the quantity of consumed water is counted. When the target value is reached, at the first cycle without the "Tablet" ,the regeneration cycle is performed.
- *If the level set is equal or more than L5: the regeneration cycle is performed when the quantity target is reached.

-If the washing program is a "prewash program", the regeneration cycle is not performed.

-If user cancels a program during regeneration or after regeneration and before resin wash, at the beginning of the next program the dishwasher performs the resin wash to remove the salty water from the resin chamber. The resin wash will be: load 2 lt of water with drain pump on.

-During the resin wash, the circulation Pump must be OFF.

-If the level of regeneration step is incremented, (for ex: from level3 to level 6) ,at the end of the next washing cycle, it must perform resin wash.

-If the regeneration level is decremented, (for ex: from level4 to level 3); checked how much water used until then and according to new level, how much water will be used more for resin wash is calculated.(level 3=64 lt- used liters until then).

-During waiting step of regeneration process, end user open/close the door or Power OFF /ON condition, program goes to END, but next step of washing cycle starts with resin wash, so that water level resets to zero and re-counts down from corresponding water level.

- When there is no flowmeter connection (by removing flowmeter cable), Electronic card saves the water as 4,58 lt per step.

-If there occurs regeneration step after the programs without drying step or programs having less than 15min drying step, at the end of the program (before reg cycle) the duration must be corrected from 0:01 to 0:15 and recount down during reg step.

6.5 FEATURE OF TIME PHASE

- At the beginning of the main wash of eco program, If temperature of water < 30C , Time phase is not activated at the main wash of eco program
- At the beginning of the main wash of eco program, If temperature of water > 30C , Time phase is activated at the main wash of eco program
- These two rules cover only eco programs.

6.6 VOLTAGE SENSING CONTROL

When main supply voltage is below 145VAC, voltage sensing circuit detect low voltage and program is stopped by software.

Take memory failure code of low voltage to show at the beginning of service test.

After main supply voltage is above 155VAC, program is started again

When main supply voltage is above 285VAC, voltage sensing circuit detect high voltage and program is stopped by software.

Take memory failure code of high voltage to show at the beginning of service test.

After main supply voltage is below 275VAC, program is started again

- If voltage is low or high during 3 hours or more, at the end of the 3 hours:
 - Program go to failure routine without draining, Failure code of low voltage is shown to user
 - Program go to failure routine without draining , Failure code of high voltage is shown to user

For 110V models: Low voltage detection is not available, only high voltage is detected as following:

When main supply voltage is above 145VAC, voltage sensing circuit detect high voltage and program is stopped by software.

Take memory failure code of high voltage to show at the beginning of service test.

After main supply voltage is below 135VAC, program is started again

- If voltage is high during 3 hours or more, at the end of the 3 hours:
 - Program go to failure routine without draining , Failure code of high voltage is shown to user

6.7 NTC VALUES

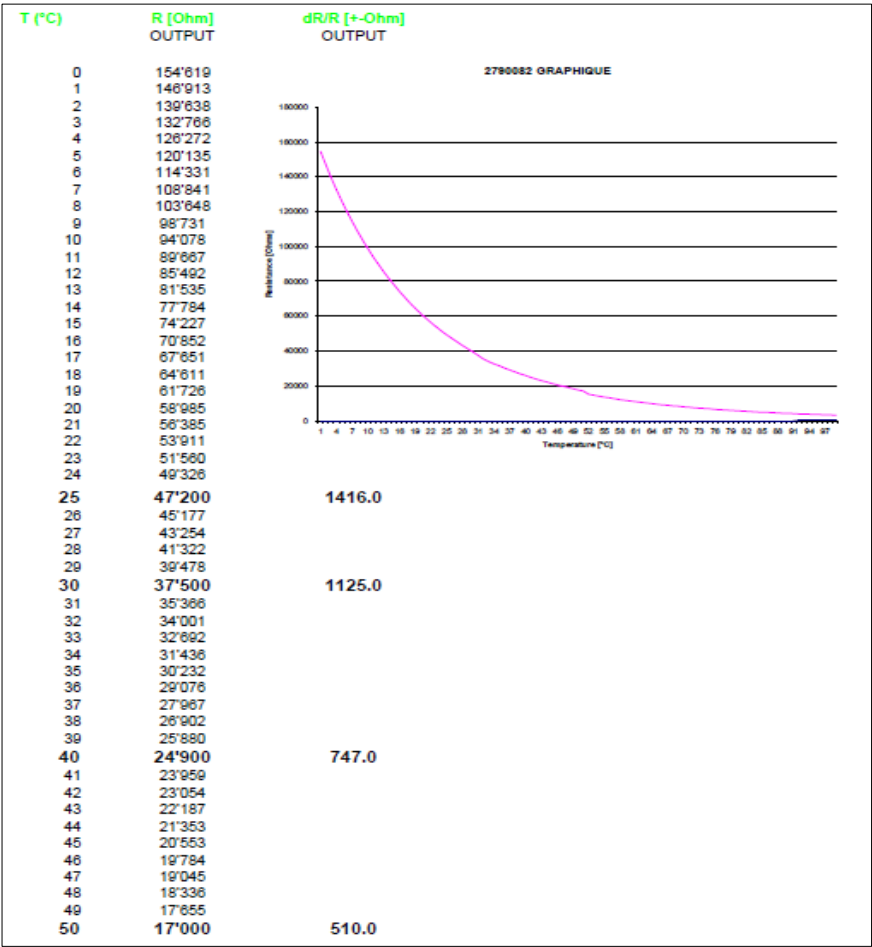

T (°C)	R (Ohm)	dR/R (+-%)
51	16'371	
52	15'768	
53	15'185	
54	14'626	
55	14'090	
56	13'573	
57	13'077	
58	12'600	
59	12'141	
60	11'700	351.0
61	11'295	
62	10'905	
63	10'531	
64	10'171	
65	9'824	
66	9'491	
67	9'171	
68	8'862	
69	8'566	
70	8'280	248.0
71	8'005	
72	7'740	
73	7'485	
74	7'240	
75	7'004	
76	6'776	
77	6'557	
78	6'345	
79	6'141	
80	5'945	178.0
81	5'756	
82	5'573	
83	5'397	
84	5'227	
85	5'064	
86	4'906	
87	4'753	
88	4'606	
89	4'464	
90	4'327	
91	4'195	
92	4'067	
93	3'944	
94	3'825	
95	3'709	
96	3'598	
97	3'491	
98	3'387	
99	3'287	
100	3'190	

6.8 WATER HARDNESS SET

Only service can execute this procedure. This procedure erases the cycle counter.

If it is the first water hardness set, default Water hardness level set is L3 as default.

1. Open the door of the machine,
2. Switch on the machine and press Program button immediately and hold it down for 3",
Note: For TOUCH models by pressing Program button switch on the machine and continue to press Program button for 3"
3. If "Hardness Set" is recognized, "SL" will be shown on the display for 2" (For models without display: when water hardness set is recognized, all leds blink once). And the last setted level will be shown on the display. (release the program button)
- 4.
5. Press Program button to set the desired level. At any pressure of Program button, hardness level is incremented. It returns to hardness level 1 after hardness level 6.

	For 60 cm	For 45 cm
Water Hardness level	Litres	Litres
Level 1	Never	Never
Level 2	116 lt	100 lt
Level 3	64 lt	72 lt
Level 4	52 lt	41 lt
Level 5	46 lt	28 lt
Level 6	16 lt	14 lt

Level	Display
1	L1
2	L2
3	L3
4	L4
5	L5
6	L6

Note: For I1 models withOUT display: when Salt level is changed, leds shown below table will be on.

Salt level	P1	P2	1/2	3h	6h	9h
L1	X					X
L2		X				X
L3			X			X
L4				X		X
L5					X	X
L6	X				X	X

I16

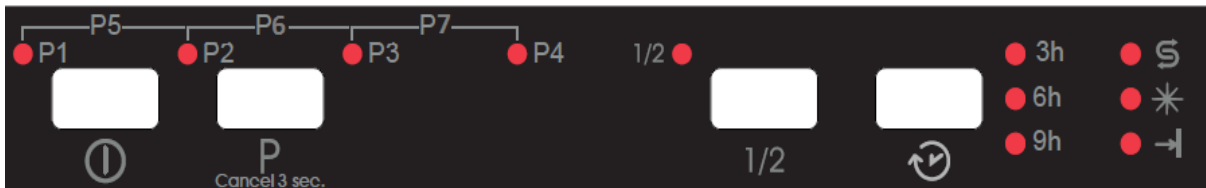

I16_7

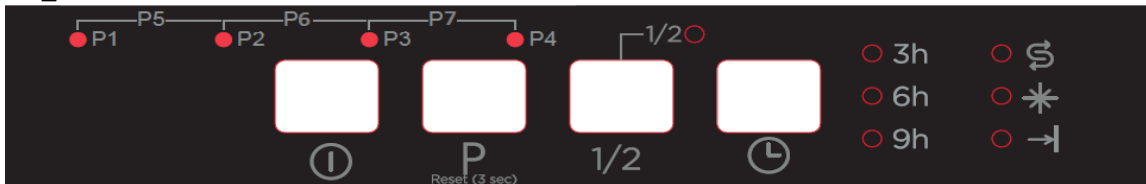

Note: For I14_5, I21_5 60 cm commercial model; when Salt level is changed, leds shown below table will be on.

Salt level	P1	P2	P3	P4	P5
L1	X				X
L2		X			X
L3			X		X
L4				X	X
L5	X			X	X
L6		X		X	X

I14_5 60 cm Profesyonel

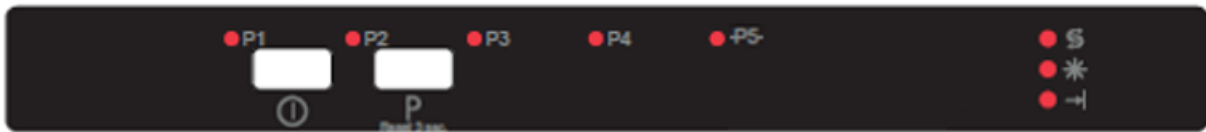

I21_5 60 cm Profesyonel

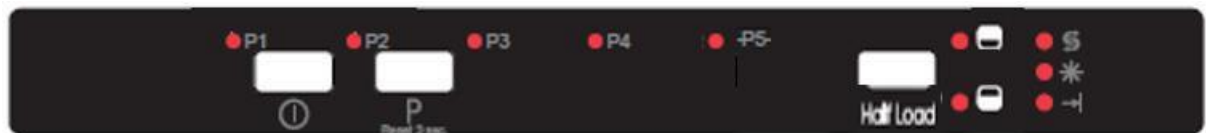

6.9 RINSE AID SET

If it is the first rinse aid set, default rinse aid level is r4 which corresponds to 4,5 cc.

1. Open the door of the machine,
2. Switch on the machine and press Program button immediately and hold it down for 5",
 - For models without display: when rinse aid set is recognized, all leds blink twice.
 - For models with 188 digit display: when rinse aid set is recognized, "rA" will be shown on the display for 2sec.

Note: For TOUCH models by pressing Program button switch on the machine and continue to press Program button for 5"

3. Release program button. The last setting level is viewed*.
4. At any pressure of **Program** button Rinse aid level is incremented. Rinse aid level 1 returns after level 5.

Level	Display
1(0cc)	r1
2(1,5cc)	r2
3(3cc)	r3
4(4,5cc)	r4
5(6cc)	r5

Note: For I1 models withOUT display: when Rinse aid level is changed, leds shown below table will be on.

Rinse aid level	P1	P2	1/2	3h	6h	9h
r1 (0 cc)	X					X
r2 (1.5 cc)		X				X
r3 (3 cc)			X			X
r4 (4.5 cc)				X		X
r5 (6 cc)					X	X

I16

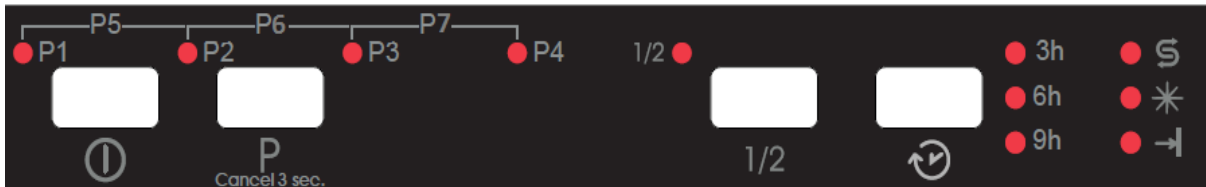

I16_7

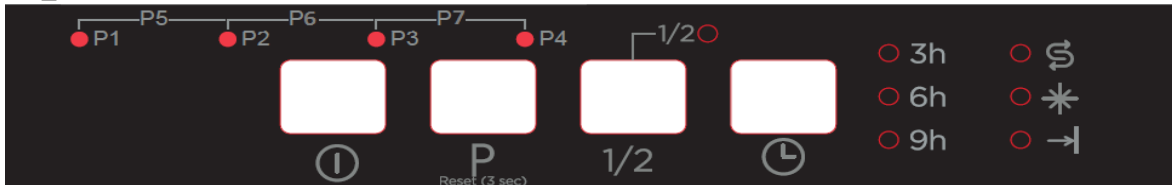

Note: For I14_5, I21_5 60 cm commercial models; when Rinse level is changed, leds shown below table will be on.

Rinse aid level	P1	P2	P3	P4	P5
r1 (0 cc)	X				X
r2 (1.5 cc)		X			X
r3 (3 cc)			X		X
r4 (4.5 cc)				X	X
r5 (6 cc)	X			X	X

I14_5 60 cm Profesionel

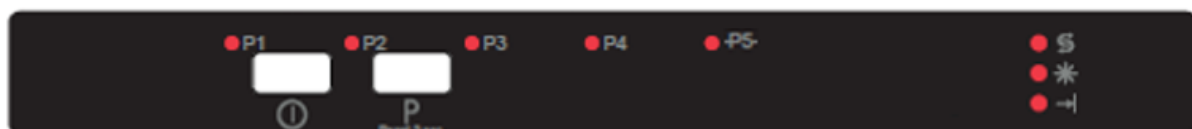

I21_5 60 cm Profesyonel

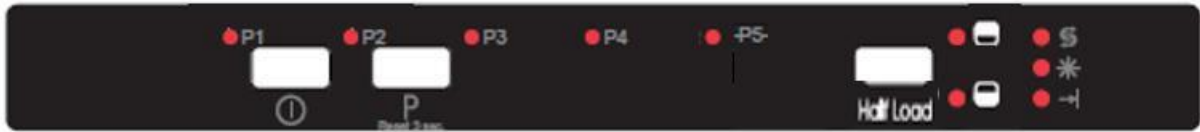

If the rinse aid tank is empty and user sets rinse aid level as 1(0cc), "lack of rinse aid" warning is not shown.

Sliding dispenser dosages are shown below in detail.

- 1 rinse aid dosage is performed when dispenser is ON during 8" and OFF during 8". =>1,5cc
- 2 rinse aid dosages are performed 8" ON-8" OFF-8" ON-8" OFF=>3cc
- 3 rinse aid dosages are performed 8" ON-8" OFF-8" ON-8" OFF-8" ON-8" OFF=>4,5cc
- 4 rinse aid dosages are performed 8" ON-8" OFF-8" ON-8" OFF-8" ON-8" OFF-8" ON-8" OFF =>6cc

<i>Action</i>		<i>New(Sliding dispenser)</i>	
Detergent cover opening:		0.3"	
Rinse aid dose:	Dose setting:	Automatic in the software	
	Dose quantity and time to delivery	1 - 0cc	OFF
		2 - 1.5cc	8"ON; 8"OFF
		3 - 3cc	8"ON; 8"OFF
		4 - 4.5cc	8"ON; 8"OFF
		5 - 6cc	8"ON; OFF
		n/a	n/a
Standard dose of rinse aid setting by manufacturer		(4-4,5cc set by software)	

6.10 INNER LIGHT

Machine must be on and door must be open position during changing of inner light modes (ECO "IL1" or Normal "ILO" modes). Factory setting for inner light is set to ECO mode "IL1".

For I1x 60 cm models:



For I1x, I2x 45 cm models

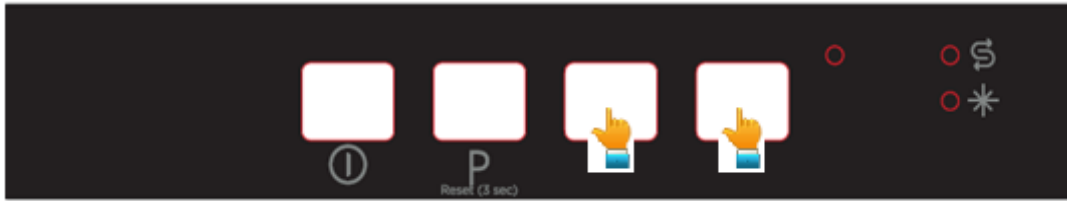

For I2x 60 cm models:



For I5x 60, 45 cm models:



i. How to change from “ECO MODE” to “NORMAL MODE” for Inner Light option:

Press two specified buttons simultaneously for 3 seconds as indicated on the above user interfaces. “IL0” will be shown on the display (top and front) for 2 seconds to show the “Normal Mode” is selected for inner light option. After “Normal Mode” is selected, the inner light will be ON as long as the machine is energized and door is open.

ii. How to change from “NORMAL MODE” to “ECO MODE” for Inner Light option:

Press two specified buttons simultaneously for 3 seconds as indicated on the above user interfaces. “IL1” will be shown on the display (top and front) for 2 seconds to show the “Eco Mode” is selected for inner light option. Also inner light blinks to show this selection is activated. After “Eco Mode” is selected, the inner light will be ON for 4 minutes after the door is opened and then turns OFF. Then display returns its usual position. (Ex: 3” Pn, 1” time). If any user intervention occurs such as pressing buttons, Eco Mode cycle starts from beginning (inner light is ON for 4min and then becomes OFF again).

Note: For I1 models withOUT display: when inner light mode is changed, leds shown below table will be on.

I1 models withOUT display Inner light	P1	P2	1/2
ECO mode -> Normal mode	X	X	
Normal mode -> ECO mode	X	X	X

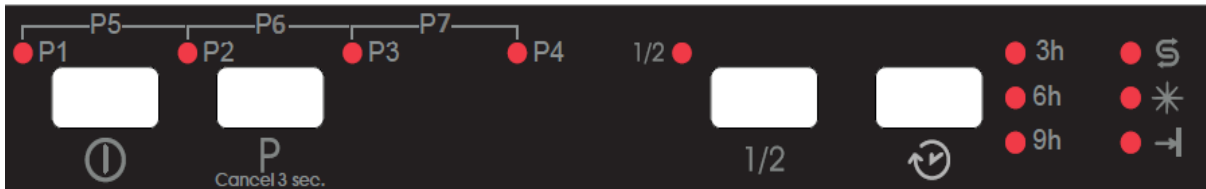

I16_7

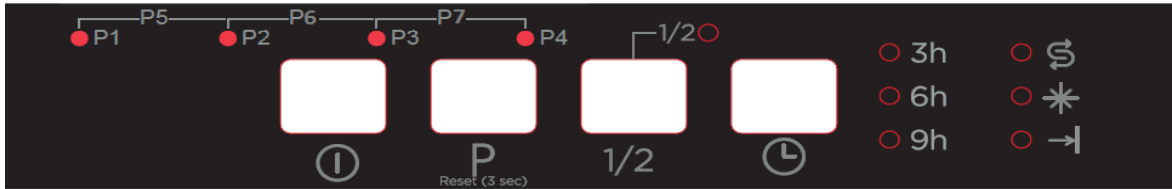

Note: There is no inner light setting on I14_5 commercial model. Eco mode will be default.

Note: For I21_5 commercial model; press Program and Half Load buttons for 3 seconds to change inner light settings. When inner light mode is changed, leds shown below table will be on.

I21_5 - Inner light	P1	P2	P3
ECO mode -> Normal mode	X	X	
Normal mode -> ECO mode	X	X	X

I21_5 60 cm Profesyonel

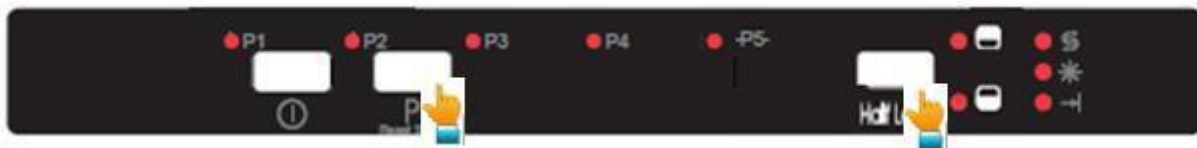

6.11 IONIZER

Ionizer function is activated/deactivated by pressing “Half load” button for 3” (For I21-I22-I23-I24 45 cm models, press “P + HL” buttons simultaneously for 3”). At the end of 3” display shows “Ion” to indicate that ionizer is activated.

When the door is closed and the function is selected, ionizer function will start.

Ionizer cycle is as follow: 5’ ON, 55’ OFF, 5’ ON,55’ OFF,.. After 24 hours is completed, ionizer function is deactivated automatically by software. During 5’ ON; ionizer component and mini fan work together. During 55”, they do not work.

If there is no intervention, it continues until 24 hours is completed. After 24 hours, it is automatically deactivated. When ionizer deactivated, machine goes to standby position.

Ionizer does not work together with any program or not executed in any program.

When the door is opened during ionizer is active, ionizer led and inner light will turn on, ion led lights up like dimming. Also, “Ion” blinks on the display. Ionizer function pauses if the door is open. To continue, the door must be closed.

When machine is turned off and then on, ionizer function is cancelled.

For I1x 60 cm and 45 cm without display models: when ionizer is activated, **P1** and **P2** leds turn on.

6.12 UVON

Uvon function are optional for only BLDC models. Asynchronous models do not have this function.

For 60 cm BLDC models:

UVON function is activated/deactivated by pressing “Half load” button for 6” (For I24 45 cm model, press “P + HL” buttons for 6”). At the end of 6” display shows “**U1**” for 2” to indicate that ionizer is activated. If user presses less than 6”, Ion is activated. When UVON is deactivated, display shows “**U0**” for 2”.

UVON led is driven from the same output with ionizer fan. UVON is active only in program having drying phase. If UVON is activated and washing program is started, UV led turns on during the first 10 minutes of drying phase.

Also, if regeneration occurs and UVON is active, UV led will be on during the first 10’ of regeneration.

Default set is U0.

At the end of program, if user don’t deactivate it, UVON remains active until machine is turned off and on. When machine is turned off and then on, UVON is deactivated.

If UVON is active, ion led lights up like dimming during door is open.

UV led is never ON when the door is open. Status of leds are given below:

State&UVON	UVON is OFF		Standby & UVON is ON		Program is washing & UVON is ON		During first 10’ of Drying Phase & UVON is ON		After first 10’ of Drying Phase & UVON is ON		Program is end & UVON is ON		If machine is turned off and on, UVON will not be ON	
	ON	OFF	ON	OFF	ON	OFF	ON	OFF	ON	OFF	ON	OFF	Açık	Kapalı
UV-A led	x	x	x	x	x	x	x	✓	x	x	x	x	x	x
Ionizer leds	x	x	✓	x	✓	x	✓	x	✓	x	✓	x	x	x

X: led is off

✓:led is on

For I24 7, I54 7 (45 cm) models:

For only these slim models, since UV is driven same pin with DC fan, UV led is on during the fan is active on the drying phase with fan as default. During the drying without fan, UV led is off. (UV led lighting does not depend on whether it is activated or deactivated by pressing related button.)

UVC1 NOTE: In models with UVC1, only the following feature will be different than normal:

- There is no ion function, UV is activated/deactivated by pressing the relevant button for 3 seconds. In the form of 3-2-1-U0 / U1.

6.13 AUTOMATIC PROGRAM(TURBIDITY SENSOR)

Turbidity sensor is performed in the “auto delicate”, “auto normal” and “auto intensive” programs.

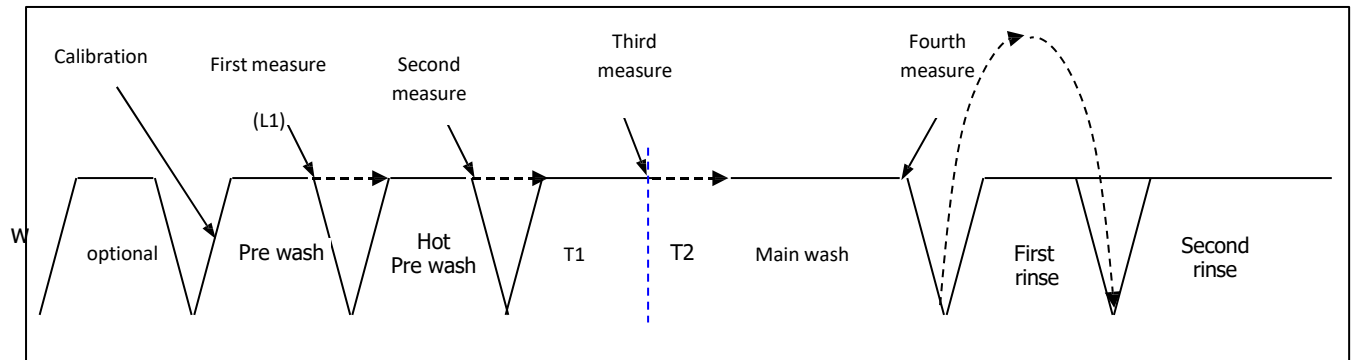

- 1) The calibration is executed after reaching P1 level in the first filling step.
- 2) The first measure is executed at the end of pre-wash.
 5. If turbidity is \leq TURBIDITY-LEVEL 1: drain is skipped.
 6. If turbidity is $>$ TURBIDITY-LEVEL 1: drain is skipped.
- 3) The second measure is executed at the end of hot pre-wash.
 7. If turbidity is \leq TURBIDITY-LEVEL 2: Drain is skipped.
 8. If turbidity is $>$ TURBIDITY-LEVEL 2: Drain is skipped.
- 3) The third measure is executed after the first heating step in the main wash.
 9. If turbidity is \leq TURBIDITY-LEVEL 3: The second heating step is skipped
 10. If turbidity is $>$ TURBIDITY-LEVEL 3: The second heating step is performed (T24_7 is performed)
- 4) The fourth measure is executed at the beginning of rinses.
 11. If turbidity is \leq TURBIDITY-LEVEL 4: First rinse is skipped.
 12. If turbidity is $>$ TURBIDITY-LEVEL 4: First rinse is executed.

The levels :

TURBIDITY-LEVEL 1 = 3,0V
 TURBIDITY-LEVEL 2 = 3,4V
 TURBIDITY-LEVEL 3 = 3,7V
 TURBIDITY-LEVEL 4 = 3,8V

In case of break of turbidity sensor, the Automatic cycle is entirely executed. The fault is not reported.

6.14 AUTODOOR OPEN SYTEM

Energy save option is not selectable at any time. During program, energy save option cannot be cancelled or cannot be added. If user presses energy save button during program, the buzzer gives a long sound that is activated to warn that this is not a valid command.

Energy save option is enable by firstly pressure of Extra button (Energy save led lights up) before starting the program.

Energy save option is disabled by pressing Extra button until Energy save led turns off.

- When option is selected, The door is opened by the Door Open System at the end of washing program.
- Program in the 1 (Last 1 minute before program finishing)
 - Start to count 2 minutes in the memory
 - TY4 triac is driven by microcontroller and door open system is energized
 - The buzzer gives sound (1"ON + 4"OFF) until auto door mechanism open the door
 - There is 1 on the display during this time.
- When Auto door mechanism open the door
 - TY4 triac is not driven by microcontroller
 - There is 0 on the display.
 - Stop to count 2 minutes in the memory
- If Auto door is not opened in 2 minutes
 - TY4 triac is not driven by microcontroller
 - There is 0 on the display.
 - FC failure code is saved to memory

Machine must be ON position during activation and deactivation of door open system. Position of the door (open/close) is not important to activate/deactivate the system. But during washing cycle, it is not enabled to activate /deactivate to this feature.

- How the system works:
 - The unlocked door goes down.
 - TY4 triac are used to control of auto door mechanism.
 - The mechanism stops the door at 10 cm opening.
- Benefits:
 - At hot rinse step, the water is heated up to reasonable values and A class drying is provided by letting the steam flow away to air from the dishwasher.
 - Some of required heating energy for drying is saved at hot rinse step.

Factory setting for auto door open system is set to "OFF" except Eco program

Factory setting for Eco program is set to "ON".

Auto door option button is illuminated (ON) when user selects at only Eco program by each pressing program selection button.

In Eco program, Auto door must be opened in every cycle until the end user unselect the Energy save option for Eco program. That is to say, In first cycle of Eco or other cycles, Auto door system must be performed (ON) until end user deactivate Auto door system.

Due to Eco design requirements, each energized of the machine (by pressing ON/OFF) Eco program must be fixed as default, energy save option led must be ON(only valid for Eco) and the options that are chosen before will be cancelled.

For ex: when user power OFF/ON→ Eco program is fixed as default, energy save option led is ON.

Then if user press again program button, in this case machine passes to Dual pro wash, but energy save option led must become OFF.

6.15 AUTODOOR CONTROL TEST

For I1x w/ display and I2x 60 cm models:

Open the door of the machine. Switch-on the dishwasher. Press **Options** button immediately and hold it down for 5". After 5", display shows "dc" (means that door control) characters during 2 sec, then "1" character appear. Then close the door to start the test.

I1x w/ display



I2x 60 cm



For I24 45 cm models:

Open the door of the machine. By pressing **1/2/Options** button switch-on the dishwasher, when machine is on continue to press **1/2/Options** button for 5". After 5", display shows "dc" (means that door control) characters during 2 sec, then "1" character appear. Then close the door.

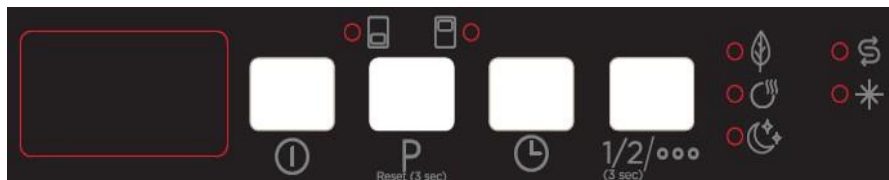

For I5x 60 cm models:

Open the door of the machine. By pressing **Dry** button switch-on the dishwasher, when machine is on continue to press **Dry** button for 5". After 5", display shows "dc" (means that door control) characters during 2 sec, then "1" character appear. Then close the door.





- Program in the “1” (Last 1 minute before program finishing)
 - Start to count 2 minutes in the memory
 - TY4 triac is driven by microcontroller and door open system is energized
 - The buzzer gives sound (1”ON + 4”OFF) until auto door mechanism open the door
 - There is 1 on the display during this time.
- When Auto door mechanism open the door
 - TY4 triac is not driven by microcontroller
 - There is 0 on the display.
 - Stop to count 2 minutes in the memory
- If Auto door is not opened in 2 minutes
 - TY4 triac is not driven by microcontroller
 - There is 0 on the display.
 - FC failure code is saved to memory

-Test can be finished by pressing On/Off button.

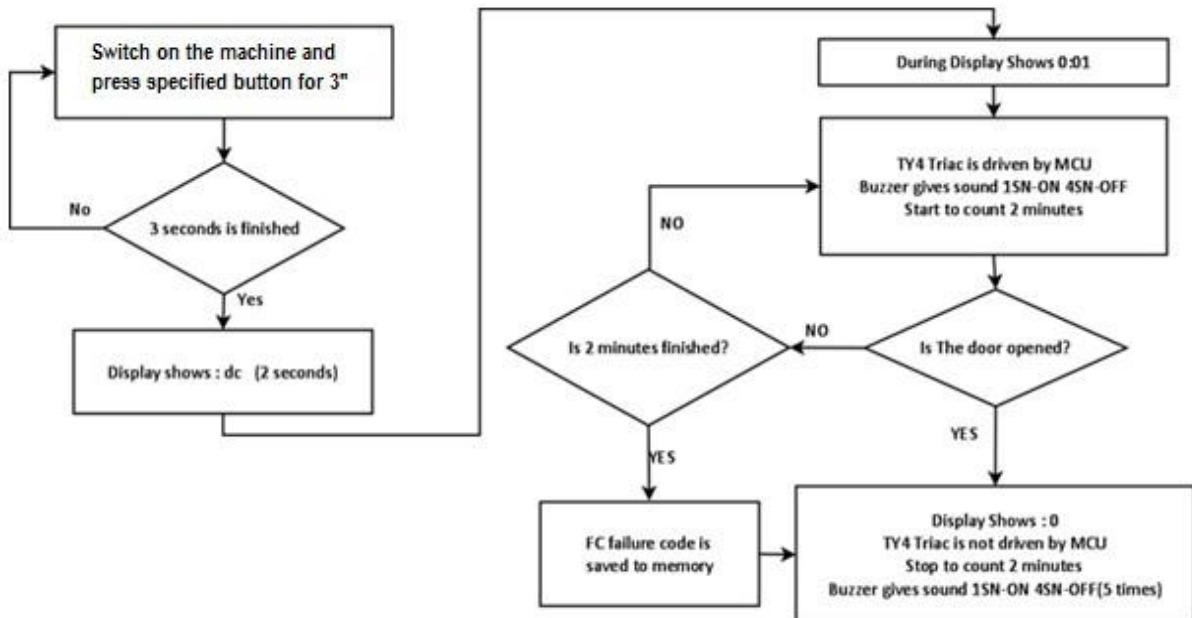

6.16 BLDC MOTOR CONTROL TEST

For I2x 60 cm models:



Open the door of the machine. Switch-on the dishwasher. Press **1/2** and **Options** button immediately and hold them down for 5". After 5", display shows "Pc" (means that Pump control) characters during 2 sec, then "20" characters appear and BLDC motor start performing with 2000 rpm. To increase RPM values press **Options**, to decrease RPM values press **1/2** button.

Press "**Options**" button to increase RPM values from 2000 to 3400.(20,21,22,...,34)

Press "**1/2**" button to decrease RPM values by hundred from 3400 to 2000.(34,33,32,...,20)

For 124 45 cm models:

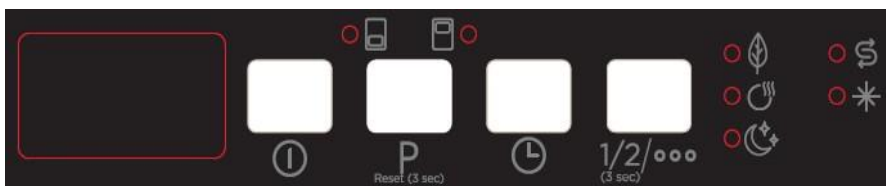

Open the door of the machine. By pressing **Delay** and **1/2** buttons simultaneously switch-on the dishwasher, when machine is on continue to press **Delay** and **1/2** buttons buttons for 5". After 5", display shows "Pc" (means that Pump control) characters during 2 sec, then "20" characters appear and BLDC motor start performing with 2000 rpm.

Press "**1/2**" button to increase RPM values from 2000 to 3400.(20,21,22,...,34)

Press "**Delay**" button to decrease RPM values by hundred from 3400 to 2000.(34,33,32,...,20)

For 15x 60 cm models:



Open the door of the machine. By pressing **Upper/Lower basket button** button switch-on the dishwasher, when machine is on continue to press **Upper/Lower basket button** button for 5". After 5", display shows "Pc" (means that Pump control) characters during 2 sec, then "20" characters appear and BLDC motor start performing with 2000 rpm.

Press "**Extra Silent**" button to increase RPM values from 2000 to 3400.(20,21,22,...,34)

Press "**Extra Dry**" button to decrease RPM values by hundred from 3400 to 2000.(34,33,32,...,20)



Rpm values can be raised or decreased one by one.

Test can be finished by pressing On/Off button.

6.17 WATER SAVE CONTROL TEST

For I25 model: Switch on the machine and press **P and 1/2** buttons simultaneously for 5“.



For I55 model: Press **Extra Silent/Fast** button then switch on the dishwasher. Please keep pressing **Extra Silent/Fast** buttons for 5“.



After 5“, display shows “rc” (means that recovery control) characters during test. The buzzer gives **sound (1”ON + 4”OFF)** during test except “buzzer sound finishes step” in below diagram.

Pressing any button does not affect the test and any invalid buzzer sound is not heard while water save algorithm in below diagram is continuing.

At the end, buzzer gives long sound.

Test can be finished by pressing On/Off button.

Notes:

1. If a program is started after Eco/Eco5.4lt program, water inside the water save tank is drained at the beginning of the program.
2. After water save tank is full, user must press Program button to continue the test. If Program button is not pressed, test does not continue.
3. If machine turns off/on while test is being executed, machine turns to standby position.

During the test below algorithm is applied:

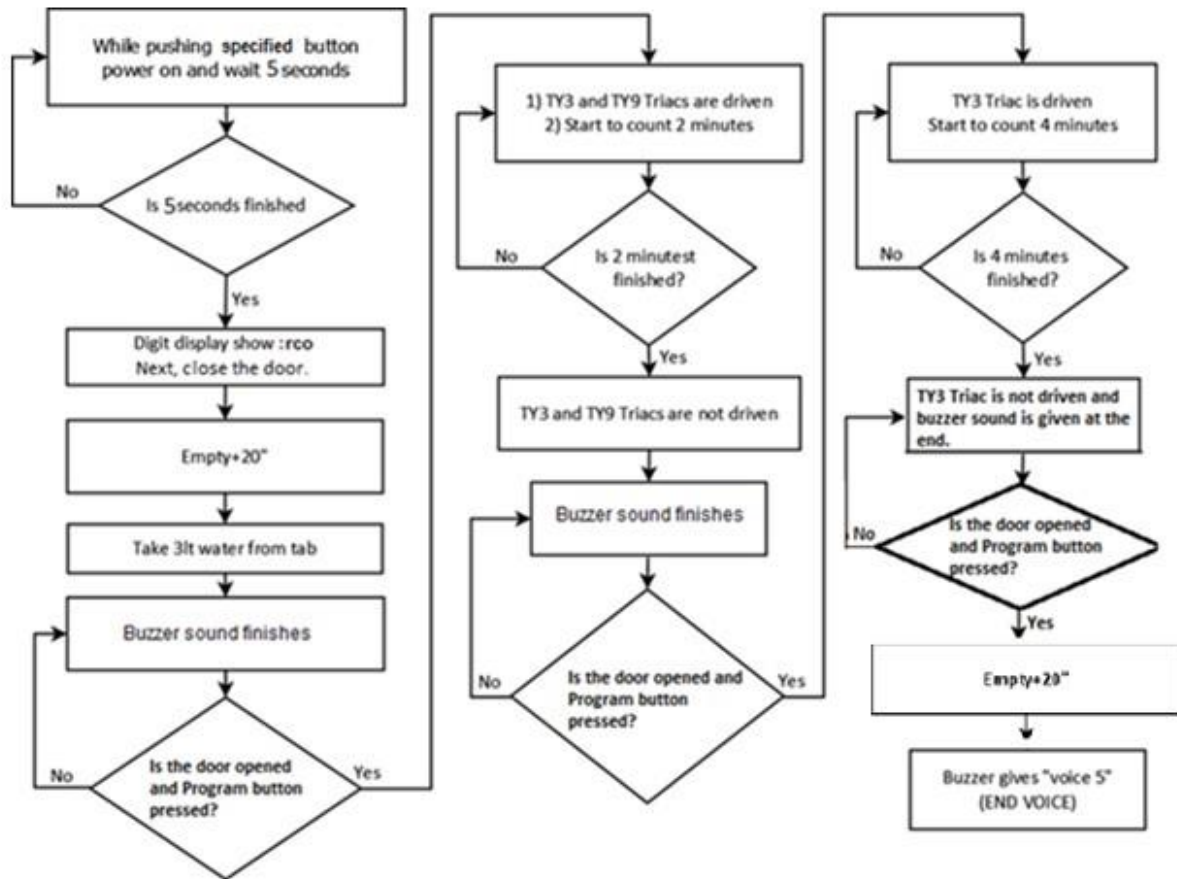

6.18 VOICE CONTROL TEST

For I1x 60 cm models:



For I2x 60 cm models:



For I1x, I2x 45 cm models:

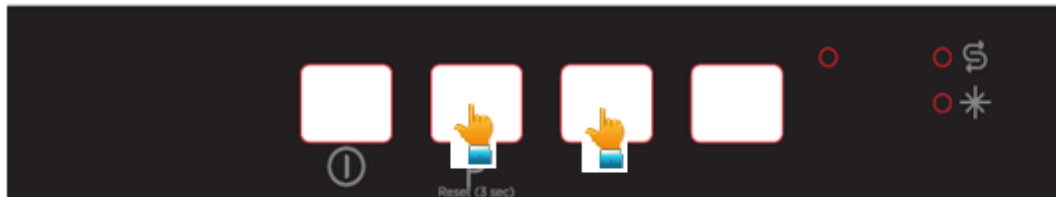

For I5x 60, 45 cm models:



First energize the machine via main switch (if it is in OFF position).

Press two specified buttons simultaneously for 3 seconds as indicated on the above user interfaces.

If voice controlling is done at first time, at the end of 3 seconds, "S3" is shown on the display and Buzzer gives a long sound. (level of 3) (Factory setting is set to "S3")

User can increase or decrease the voice level with specified buttons. The characters must be as follow;

By each pressing button which specified right side of the combination:

- Display screen changes S0 to S3
- Level of sound increases step by step

By each pressing button which specified left side of the combination:

- Display screen changes from S3 to S0
- Level of sound decreases
- "S0" level means all voices are off

Note: For I1 models withOUT display: when voice level is changed, leds shown below table will be on.

Voice Levels	1/2	3h	6h	9h
S3	X	X	X	X
S2		X	X	X
S1			X	X
S0				X

I16

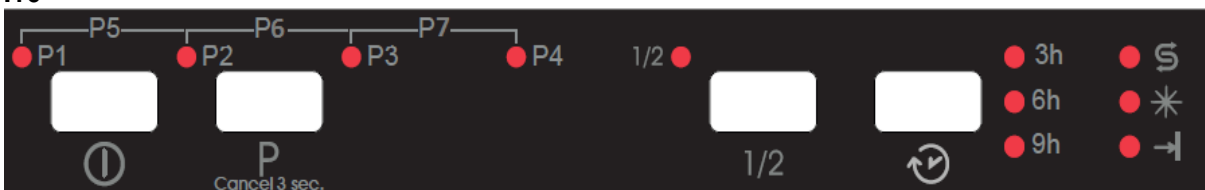

I16_7

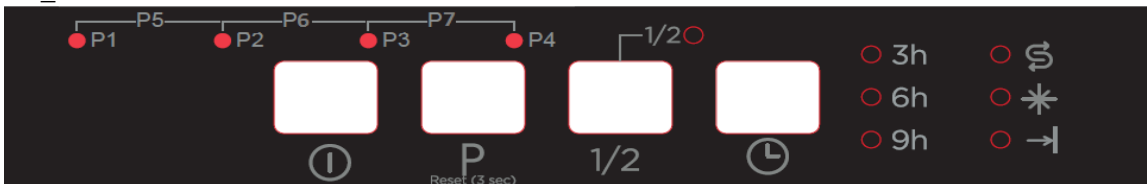

To save the determined voice level and exit voice control mode, switch off the machine.

After program finished, buzzer sounds for 3 times at 5 minutes intervals.

Note: There is no buzzer level setting on I14_5, I21_5 commercial models due to lack of buttons. Buzzer level will be S3 as default.

6.19 INFOLEDS

Infoled 1.0

Infoled provides user to understand program state(working/ended) and see warnings when error occurs.

- While program is running and door is closed, digits are on(188 is on).
- When the door is opened 188 will be off and instead, program duration/number will be shown as ready position.
- When the program ends, digits are off(188 is off)
- If an error occurs during program, warning occurs such that 188 will blink at 0.5 second intervals. (188 is on during 0.5", 188 is off 0.5", 188 is on during 0.5",...)
- If program is cancelled by user, during cancellation process 188 will blink at 1 second intervals. At the end of cancelling, 188 is off. This behaviour will not be performed in Empty+20" steps in the program. This will occur only if program is cancelled.

Infoled 2.1 Behavior

In all built-in models (60-45cm):

- While the program is running, the red LED lights continuously. When the program is finished, the green LED lights continuously.
 - If no action is taken when it is over, after 15 minutes, the green LED turns off with auto off. During this time, if any button is pressed on the machine, the machine goes to the ready state and the green led turns off.
 - During the cancellation process, the red led flashes at 1 second intervals.
 - In case of error, the red led flashes at 0.5 second intervals..
- When the door is opened, the infoleds turn off, only when the door is in the finished state, the green led continues to light.
- IL2.1 shows the same behavior as the program run during the service test, the green led lights up when the service test is over. If the machine goes into error during the service test, the red led lights up at 0.5 second intervals.

- In End test 1, after the 10th second, green and red light together, in End test 2 the infoleds do not light, in End Test 3 the green led is on when the door is closed, and the red led is constantly on with the ion led when the door is open.

InfoLED 2.1	in ready position	While Prg, SP is running, before Okam opens, while ion or delay is active	When the door is opened while working	When the door is opened while the ion is active	After the program, cancel, Ion, SP ends (when the door is opened in +done state)	At the time of cancellation	In case of error	End Test1 after 10.sec	EndTest2	End Test3 with the door closed	End Test3 with the door open
Red	fireproof	lights up	fireproof	Flashes as breath	fireproof	Flashes at 1 second intervals	Flashes at 0.5 second intervals	lights up	fireproof	fireproof	lights up (with ion led)
Green	fireproof	fireproof	fireproof	fireproof	lights up	fireproof	fireproof	lights up	fireproof	lights up	firepro

BM05 Infoled 2.0 and Infoled 2.1 outputs		
CN11.2	7V	Ion Led+Infoled2.0 (multiplexed over the Infoled card)
CN8.2	GND	Infoled2.0 GND
CN8.3	Rinse read	Infoled 2.1 switching
CN9.2	-5V	Infoled2.1 feeding

SERVICE TEST

Only service can execute this procedure.

- Open the door. Power ON by pressing On/Off button
- Press Program button for 8"

Note: For TOUCH models by pressing Program button switch on the machine and continue to press Program button for 8"

- When "Service test" is recognized
 - All leds are ON, SP is visualized on display and service test starts. During the first 6" of test, if a failure code is stored in memory, its codification blinks. If there is no error" –" is shown on the display. Also at the end of the test if an error occurs its error code blinks. (For models without display: when service test is recognized, all leds blink thrice)
 - -Close the door .Then service program will start automatically. (After showing the last error code for 6sec like in the freestanding models- "SP" will be shown until the end of test program)

During the test, SP is shown.

- Also at the end of the test if an error does not occur during service test and completes the cycle without error, any codification is never shown. The last failure code is never shown anymore. Actually, last failure code is erased after completing the test successfully.

Step		Time	Tested Load
0	Show code	6"	Before start, the code of last error is visualized (see below)
1	Drain	6"	Drain pump.
2	Fill (3l/2,5l)*	~ 1'	Flow meter; Inlet Valve;
3/□	Turb. Calibration		Turbidity Calibration
4	Fill + Wash (0,5/1lt)**		Flow meter; Inlet Valve; Pressure Switch;
5	Wash	1'	Circulation pump; detergent dispenser. "Deterjan dispanseri tam 1 dk deęil; Step 5 in 10. saniyesinde sadece 5 sn boyunca aktif olması yeterlidir.
6	Wash + Heat ***	5'	Heater (PSW); NTC; diverter (position).
8 9	Reg. Valve + Turbo Fan	1'	Regeneration Valve + Turbo Fan
10	(Resin wash) water inlet valve + drain pump	~1' 20"	Water inlet valve (3 lt)+drain pump;to wash resin and to drain out any possible salt from the machine.
11	Drain	20"	Drain pump + circulation pump (until pressure switch empty level)

* 2,5lt in Z

** 1lt in Z

*** In service test, the unsuccessful heating failure routine works with reduced time of recognize (first measure at 2'00", second measure (4'40"))

If during the service test, the door is opened, "SP" is shown.

To reset the service test, press On/Off button or plug out and then plug in.

Also at the end of the test, if an error does not occur, "0" is visualized. Machine will be at end position. If any button is pressed, machine goes ready position.

Note: If user did not set water hardness level before service test, "SE" is shown at the beginning and end of service test.

- During Service Test, Infoled 2.1 works same as the program running.

7.1 SERVICE FAILURE CODES

Failures / Leds	(For I1 w/o digit models)					Display	Notes
	P1	P2	1/2	3h	6h		
Overflow	-	Blink	Blink	Blink	Blink	F0	In the normal work this failure is not visualized
Leakage	-	Blink	Blink	-	Blink	F1	
Drain time out	-	-	Blink	Blink	Blink	F2	
Presence Flow meter impulses	-	Blink	-	Blink	Blink	F3	
Absence of flowmeter impulses with full	Blink	Blink	-	Blink	Blink	F4	In the normal work this failure is not visualized
Re-Fill time out	Blink	Blink	-	-	Blink	F5	
Rarely/Regular flowmeter impulses with empty	Blink	Blink	-	-	Blink	F5	
Level Empty without Flow meter impulses	Blink	Blink	Blink	Blink	-	FF	Level Empty without Flow meter impulses
NTC cc/ca	Blink	-	-	Blink	Blink	F6	
Over Heating	Blink	-	Blink	-	Blink	F7	
Unsuccessful heating	Blink	-	Blink	Blink	Blink	F8	In the normal work, this failure is visualized at the end of prg.
Diverter opened	-	-	-	-	-	F9	For only with diverter models
Salt Parameter incorrect	Blink	Blink	Blink	-	Blink	SE	In the normal work this failure is not visualized.
CK Parameter	-	-	Blink	-	Blink	FE	

Turbidity Sensor	Blink	-	-	Blink	-	FA	In the normal work this failure is not visualized.
Auto Door	Blink	Blink	Blink	Blink	Blink	FC	In the normal work this failure is not visualized.
High Voltage	Blink	Blink	Blink	-	-	HI	
Low Voltage	-	Blink	Blink	Blink	-	LO	

Note: For I14_5, I21_5 commercial models, below leds will be used instead of current leds while showing failures on the display.

I1x w/o digit failure leds	I14_5, I21_5 failure leds
P1	P1
P2	P2
1/2 ->	P3
3h ->	P4
6h ->	P5

7 FAILURE ROUTINES

N°	Name	Exit of failure state	Service Call
1	Switch door open	Door closing	NO
2	Delay after door closing	7" delay before restart prg in heating step	NO
3	Overflow Leakage	Overflow signal gets off	NO
		OFF/ON	YES
4	Draining time out	OFF/ON	YES
5	Presence of Flow meter impulses	Flow Meter signal gets off.	NO
		OFF/ON.	YES
6	Absence of Flow meter impulses	Pressure switch on Full.	NO*
		Pressure switch on Empty. OFF/ON	NO/YES
7	Level Empty	Level doesn't reach full	NO/YES
8	Re-Fill	3 Re – fill in the same washing step	NO/YES
8	NTC ca/cc	OFF/ON	YES
8	Overheating	OFF/ON	YES
10	Unsuccessful heating	OFF/ON	YES
11	Diverter opened	OFF/ON	YES
12	CK Parameters	OFF/ON	YES
13	High Voltage Failure	OFF/ON	YES
14	Low Voltage Failure	OFF/ON	YES

*Cycle could be executed with a filling time.

Failure Routine

If a failure is recognized:

- Stop all devices
- Stop program flow.
- Drain Empty + 30" with circulation pump on

If the failure requires the termination of the washing program:

- Stop all the devices.
- Start to visualize the failure code.

If the failure doesn't require the termination of the washing program:

- Stop all the devices.
- Re-Start the washing program.

If it is necessary it performs the *Re-Fill routine*

Re-Fill Routine

After a forced drain (ex: a failure routine) if the dishwasher was in wash before the drain it performs the re-fill routine:

- Inlet Valve ON + circulation pump OFF to load 3l (time out 420")
- When the first load step is finished, Inlet Valve ON + circulation pump ON to load 1l (time out 100")
- Return to the washing cycle

7.10 DESCRIPTION OF FAILURES

Opened door switch

Recognize:	if door is opened with a started program
Action	Wait
Exit	Closing door.
Service	No

Delay in re-start program

Recognize:	if door is opened and re-closed in a heating step.
Action	Wait 5" before restart program.
Exit	Closing door.
Service	No

Overflow/Leakage

Recognize:	5" with overflow pressure sensing = on.
Action	Go to Failure routine.
Exit	If overflow signal gets off until failure routine finishes (cause is overflow): washing program restarts. It re-fills water according to Re-Fill routine and it continues to wash. If overflow signal persists until failure routine (cause is leakage): OFF/ON.
Service	NO if overflow. YES if leakage

Only for leakage

	Display
All leds blink	F1

Draining timeout

Recognize:	180" with drain pump ON and circulation pump ON with pressure sensing in full level position.
------------	---

	Display
All leds blink	FF

Level Empty and rarely Flow meter impulses

Recognize:	With rarely flow meter impulses (time out of absence of flow meter impulses doesn't expire) it doesn't reach the second quantity of required water related to the washing cycle within the time out (100")
Action	Go to Failure routine.
Exit	OFF/ON
Service	Not necessary if the reason is a momentary. YES in the other cases.

	Display
All leds blink	F5

Level Empty and regular/rarely Flow meter impulses

Recognize:	With flow meter impulses (time out of absence of flow meter impulses doesn't expire) it reaches the second quantity of required water related to the washing cycle) but it doesn't reach the full level within the time out (30")
Action	Go to Failure routine.
Exit	OFF/ON
Service	Not necessary if the reason is a momentary. YES in the other cases.

	Display
All leds blink	F5

Re-Fill

Recognize:	During a washing step, if pressure switch goes from full level to empty level Failure routine start. Wash restarts with the Re-Fill routine (3I+1I). If pressure switch goes from full level to empty level for 3 times during the same washing step failure is recognized.
Action	Go to Failure routine.
Exit	OFF/ON
Service	Not necessary if the reason is a momentary (ex. an upside down pot). YES in other situations.

	Display
All leds blink	F5

NTC open or short-circuit

Recognize:	Recognition of open or short-circuit NTC (-20°C/86°C). Test is executed during all the program flow.
Action	Go to Failure routine.
Exit	OFF/ON
Service	YES

	Display
All leds blink	F6

Overheating

Recognize:	Water temperature $\geq 77^{\circ}\text{C}$. The test is done during all the cycle.
Action	Go to Failure routine.
Exit	OFF/ON
Service	YES

	Display
All leds blink	F7

Unsuccessful heating

Recognize:	During the heating phases, after the first 420", if water temperature increases less than 2°C or if it is less than 0° . The first valid value to check is read after 120" from the beginning of the heating step. The test is executed only if the measured temperature is lower than 60° . After door opened and reclosed during heating, temperature and time value which are read before door is opened must be cleared. Also, the control routine will start from beginning of failure routine.
Action	Skip the heating step. The test is repeated in all the heating steps. If in a following step, the heating is OK the failure is cleared. The failure is shown at the end of the program.
Exit	OFF/ON
Service	YES

	Display
All leds blink	F8

Parameters Check Sum

Recognize:	When parameter Check sum is uncorrected.
Action	Go to Failure routine.
Exit	OFF/ON
Service	The problem would disappear after switch OFF/ON of the dishwasher. If it doesn't disappear YES.

	Display
All leds blink	FE

Diverter Open Circuit

Recognize:	30" with motor of diverter valve ON and diverter sensing doesn't change
Action	Go to Failure routine.
Exit	OFF/ON
Service	YES

	Display
All leds blink	F9

Turbidity

	Display
--	---------

All leds blink	FA
----------------	----

Voltage failure

Recognize:	If the card detect high or low voltage level from main supply
Action	Stop the program . After 3 hours Go to Failure Rutine and show failure code.
Exit	OFF/ON
Service	YES

High Voltage Failure:

When high voltage (for 220V models above 285V, then 275-285VAC; for 110V models, above 145V, then 135-145VAC) detected during 3 hours

All leds blink	Display HI
----------------	---------------

Low Voltage Failure: When low voltage (blow 145V, then 145-155VAC) detected during 3 hours [Low voltage failure is not available for 110V models]

All leds blink	Display LO
----------------	---------------

Parameters Set Salt Incorrect

Recognize:	When parameter Set Salt is uncorrected
Action	Go to Failure routine.
Exit	OFF/ON
Service	NO

All leds blink	Display SE
----------------	---------------

Parameters Check Sum

Recognize:	When parameter Check sum is uncorrected
Action	Go to Failure routine.
Exit	OFF/ON
Service	The problem would disappear after switch OFF/ON of the dishwasher. If it doesn't disappear YES.

All leds blink	Display FE
----------------	---------------

Auto Door Failure

Recognize:	When auto door mechanism is activated, the door is not opened
Action	Go to Failure routine.
Exit	OFF/ON
Service	NO

All leds blink	Display FC
----------------	---------------

7.11 FAILURE CODES

Failures / Leds	(For I1 w/o digit models)					Display	Notes
	P1	P2	1/2	3h	6h		
Overflow	-	Blink	Blink	Blink	Blink	F0	In the normal work this failure is not visualized
Leakage	-	Blink	Blink	-	Blink	F1	
Drain time out	-	-	Blink	Blink	Blink	F2	
Presence Flow meter impulses	-	Blink	-	Blink	Blink	F3	
Absence of flowmeter impulses with full	Blink	Blink	-	Blink	Blink	F4	In the normal work this failure is not visualized
Re-Fill time out	Blink	Blink	-	-	Blink	F5	
Rarely/Regular flowmeter impulses with empty	Blink	Blink	-	-	Blink	F5	
Level Empty without Flow meter impulses	Blink	Blink	Blink	Blink	-	FF	
NTC cc/ca	Blink	-	-	Blink	Blink	F6	
Over Heating	Blink	-	Blink	-	Blink	F7	
Unsuccessful heating	Blink	-	Blink	Blink	Blink	F8	In the normal work, this failure is visualized at the end of prg.
Diverter opened	-	-	-	-	-	F9	For only with diverter models
Salt Parameter incorrect	Blink	Blink	Blink	-	Blink	SE	In the normal work this failure is not visualized.
CK Parameter	-	-	Blink	-	Blink	FE	
Turbidity Sensor	Blink	-	-	Blink	-	FA	In the normal work this failure is not visualized.
Auto Door	Blink	Blink	Blink	Blink	Blink	FC	In the normal work this failure is not visualized.
High Voltage	Blink	Blink	Blink	-	-	HI	
Low Voltage	-	Blink	Blink	Blink	-	LO	

Note: For I14_5, I21_5 commercial models, below leds will be used instead of I1 w/o digit model failure leds shown above while showing failures on the display.

I1x w/o digit failure leds	I14_5, I21_5 failure leds
P1	P1

P2	P2
1/2 ->	P3
3h ->	P4
6h ->	P5

Failures / Leds	(For only I21_5 model)					Display	Notes
	P1	P2	P3	P4	P5		
Diverter Open Circuit	Blink	-	-	-	Blink	F9	

I16

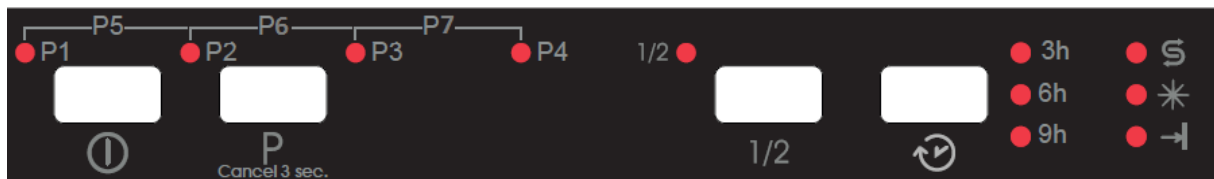

I16_7

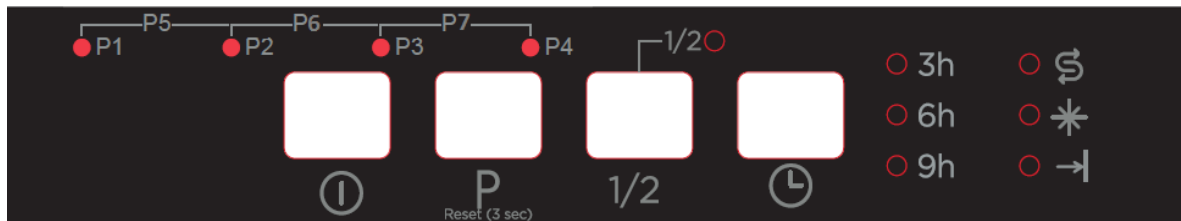

I14_5 60 cm Profesional

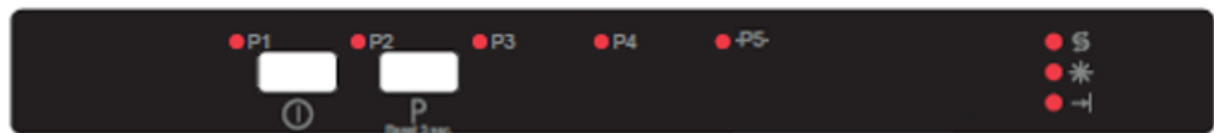

I21_5 60 cm Profesional

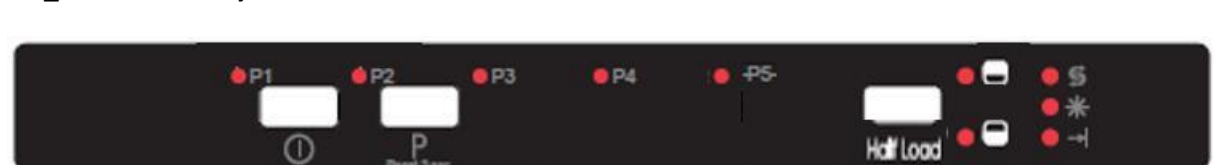

8 END TEST

End test is divided in two parts: end test 1 (functionally test) and end test 2 (heating and leakage test).

9.1 End test 1:

Vestel receives the electronic cards ready to start "end test 1". In any case, it's possible, re-start the end test 1 with a manual manoeuvre.

6. While the door is closed.
7. Switch ON the machine.
8. Press the Program Button for 3 sec. (For TOUCH models by pressing Program button switch on the machine and continue press Program button for 8")
9. All leds will blink once. Hear the beeping.
10. The End test will start automatically.

Note: To skip the End test, open door and press program button for 3" to perform the reset option and close door. After resetting, the machine is ready for use.

-After end test starts, All digits and all leds should be on together at the beginning of the end test-1 (display also show 188) during first 3 seconds.

- At the end of end test 1, switch OFF the dishwasher.

- End Test 1 de Power on/off da End Test 1 baştan başlayacak, End Test 2 de Power on/off yapılırsa kaldığı adımdan devam edecek şekilde olmalıdır. Power on/off haricindeki butonlara basıldığında ise (Örn; Az Bulaşık), normal programlarda da olduğu gibi o butonu (Az Bulaşık) algılamayacak şekilde olmalıdır. End Test 2 bitiminde ise makine direkt hazır duruma geçmelidir. Şayet iptal edildi ise, iptal işlemi sonrasında bittiye (END) geçmelidir.

Diverter failure: Stop circulation pump just after detergent dispenser activation at step 41 until the end of program if electronic card cannot detect diverter position during end test 1.

Turbidity failure: Start circulation pump just after turbidity sensor check (at step 92) for 6 sec, if electronic card realize Turbidity sensor failure during turbidity test.

If we open/close the door during end test, End test continues from the point on which we open/close the door. End test combinations keep performing.

-Salt indicator and rinse aid indicator is ON if reed sensors are short cut during end test END TEST 1 or END TEST2.

-Salt indicator and rinse aid indicator is OFF if reed sensors are not short cut during end test END TEST 1 or END TEST.

Note: In cases where the machine is energized, Power led is ON. In model codification and during end test Power led is on, but in the other test(BLDC, AutoDoor,Service, etc.) Power led is off.

* During End Test 1, both Infoleds 2.1 (red and green) turns on after 10 seconds.

9.2 End test 2

When the electronic card is switched on after the end test 1, end test 2 starts.

- 4" of pause
- Heating to reach 62°C with 13' of time out
- Only circulation pump is on for 10" sec
- Drain + Regeneration valve is on 20"
- End test 2 is finished.

During this phase, failure routine of unsuccessful heating and failure routine of NTC works. If the water temperature doesn't increase, at the end of 15', the drain pump will be on.

When the electronic card is switched on after end test 2, it will be in washing mode.

At the end of end test 2, machine turns to standby position(Eco program is shown as default).

Note: During check of Turbidity and Diverter position in the End Test1, if there occurs error, electronic card will save these errors and will go to the failure routine at the beginning of END test 2 (as NTC failure recognition)

* During End Test 2, both Infoleds 2.1 (red and green) does not work.

9.3 End test 3

When the machine is turned on after the end of End Test 2, end test 3 starts.

- **During End test 3, if and only if any button (including on/off button) is pressed on the control panel, machine left off the End Test 3 and goes ready state.**
- If the mains power cut off and on, End test 3 starts from the beginning.
- During ET3 all leds and digits on the control panel and front display illuminate.
- During End Test 3, green infoled turns on when the door is closed, red Infoled with ion led turns on when door is opened. (IL 2.1)

9 HARDWARE CONTROLS

10.1 BM05 TYPE MAINBOARD

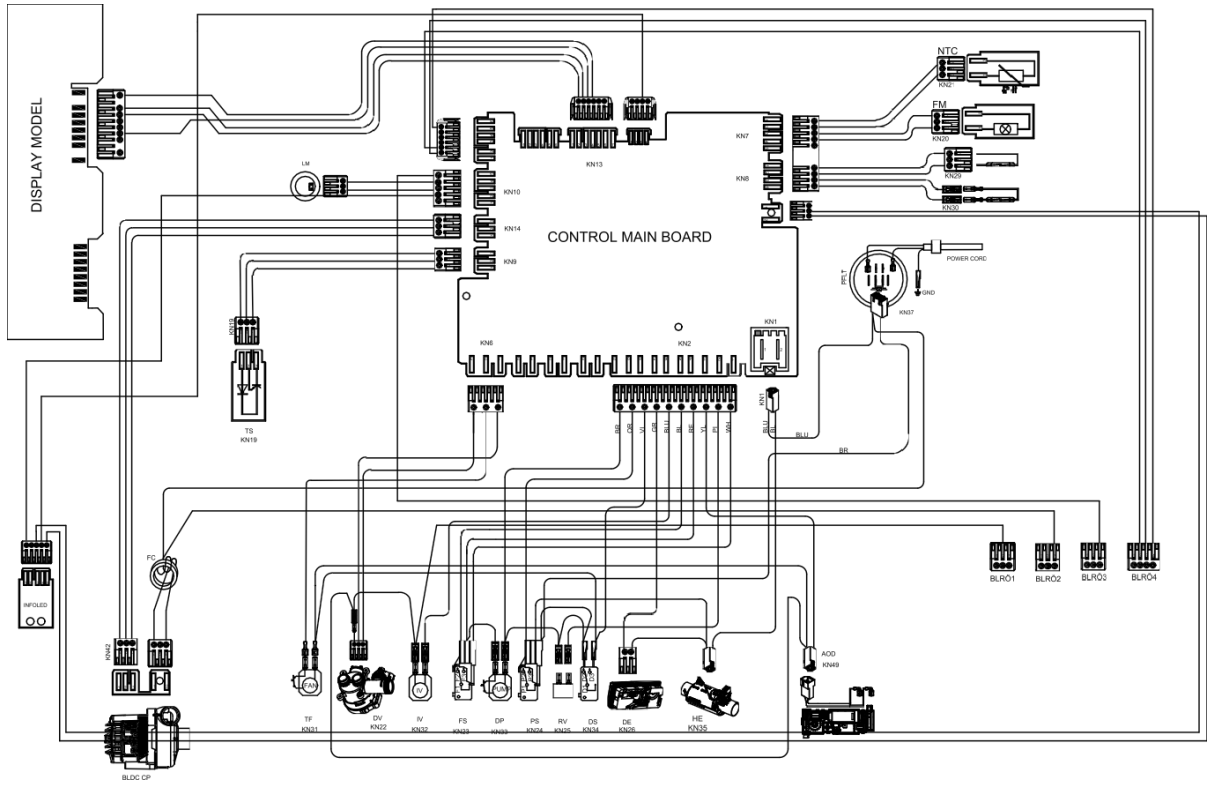
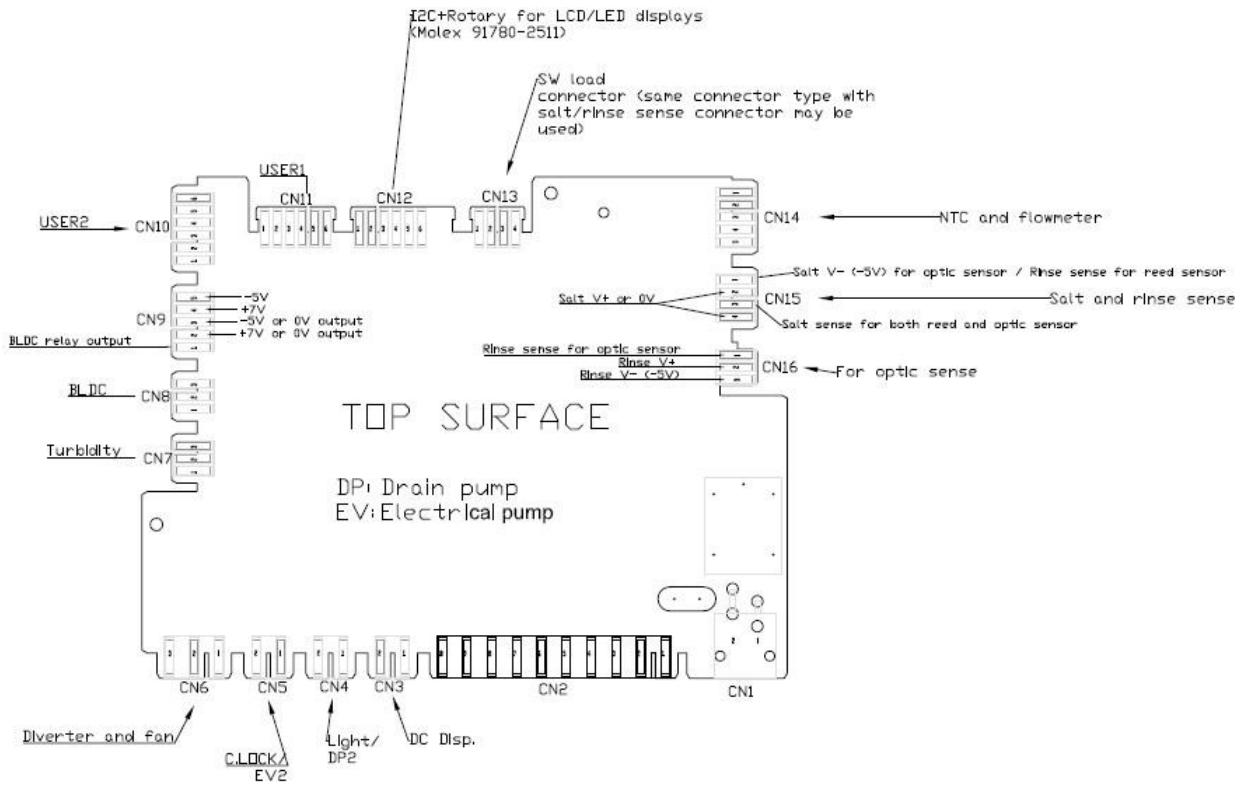

PIN	PIN OUT	COMPONENT
CN9.1	+7V transistor	Ionizer mini fan, dc main fan, uv led
CN9.2	+7V transistor	Ionizer led, infoled 2 led 1
CN9.3	+7V transistor	Dc lightening
CN9.4	-5V	Common ground
CN9.5	+7V	Sto motor

10.2 BM12 RÖLE KARTI

In all software working as of 1.4.2020:

- For I2 series BLDC models; In case of driving with BM05rev4 card and BM12 relay card, BM12 card data control is done from BM05/CN18.2

CN18							
1	2	3	4	5	6	7	8
Rx	Tx	G	-5	7	Rot	G	-5
	blr4.2(data)	blr4.4	blr4.3	blr3			

- For I5 series BLDC models; In case of driving with BM05rev4 card and BM12 relay card, BM12 card data control is done from BM05/CN12.2

CN11					CN12					
1	2	3	4	5	1	2	3	4	5	6
Vo3	Vo1	Vo2	-5	7 sabit	-5	DSDA	Dscl	Oe2	Sw2	G
				blr3	blr4.3	blr4.2(data)				blr4.4

10.3 DC FAN

For slim models, DC fan is used and it is driven through the CN11.1 connector on BM05 mainboard.

10.4 Asynchronous with Double Windings and/or Autodoor (Çift devirli ve/veya Okamlı asenkron)

- For asynchronous with double windings models; T711 is used for low RPM, T12 triac is used for high (current) RPM.

- Low speed driven from T711 triac,
- High (=current) speed is driven from the T712 triac.
- For asynchronous with Autodoor models; T711 is used for Autodoor.
- For asynchronous models with double winding and Autodoor together;
 - CN14.1 - T711 is used for Autodoor,
 - CN6.2 - T703 is used for double winding low pin,
 - CN16.1 - T710 is used for Turbo fan

10 FEATURES AND SECRET COMBINATIONS OF MODELS

116...-111 60 cm (ASYNCHRONOUS W/O DIVERTER, Converted model: D13, D21)

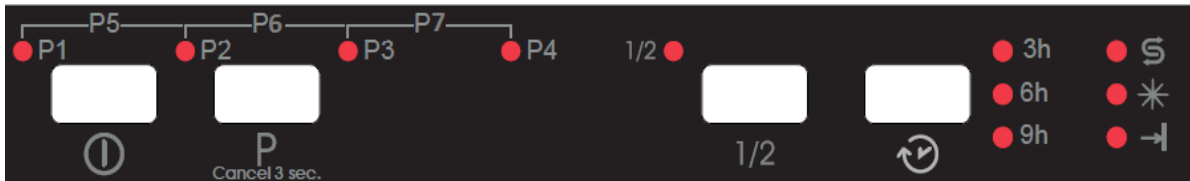

Child lock	ION	UVON	Triple&Direct	Water box	-
IL 2.1	Inner Light	Aquazone	Turbidity	Auto door	OPTIONAL
Buzzer					DEFAULT

Secret Combinations

VOICE SETUP	INNER LIGHT	ION	ADO CONTROL	BLDC CONTROL	W.SAVE CONTROL	SALT SET	RINSE AID SET	SERVICE TEST	END TEST
P(dec.) + 1/2(inc.) for 3"	1/2 + Delay for 3"	1/2 for 3"(ion)	-	-	-	open door, switch	open door,	open door, switch	close door, switch

		[P1, P2 leds will be on]				on + P for 3"	switch on + P for 5"	on + P for 8"	on + P for 3"
--	--	--------------------------------	--	--	--	------------------	-------------------------	------------------	------------------

I16--I11 45 cm (ASYNCHRONOUS W/O DIVERTER, Converted Model: D12, D21 45 cm)

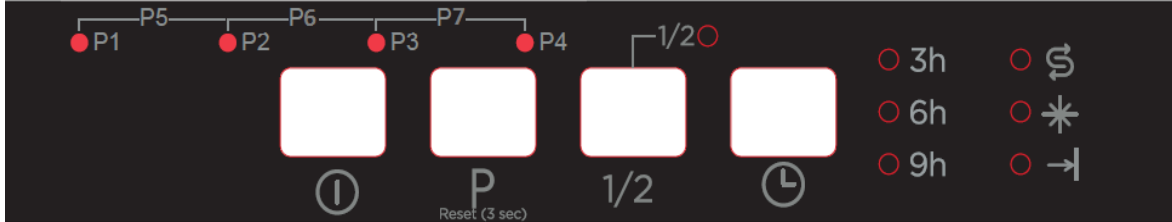

Child lock	ION	UVON	Triple&Direct W.	Auto door	Water box	-
IL 2.1	Inner Light	Aquazone	Turbidity			OPTIONAL
Buzzer						DEFAULT

Secret Combinations

VOICE SETUP	INNER LIGHT	ION	ADO CONTROL	BLDC CONTROL	W.SAVE CONTROL	SALT SET	RINSE AID SET	SERVICE TEST	END TEST
P(dec.) + 1/2(inc.) for 3"	1/2 + Delay for 3"	1/2 for 3"(ion) [P1, P2 leds will be on]	-	-	-	open door, switch on + P for 3"	open door, switch on + P for 5"	open door, switch on + P for 8"	close door, switch on + P for 3"

I1G--I1A, I1R--I1K 60 cm (ASYNCHRONOUS W/O DIVERTER, Converted Model: D22, D32, D1A)

For w/o Autodoor models:



For w/ Autodoor models:



Child lock	ION	UVON	Triple&Direct W.	Auto door	Water box	-
IL 2.1	Inner Light	Aquazone	Turbidity	Auto door (for w/ autodoor models)		OPTIONAL
Buzzer						DEFAULT

Secret Combinations

VOICE SETUP	INNER LIGHT	ION	ADO CONTROL (for w/ autodoor models)	BLDC CONTROL	W.SAVE CONTROL	SALT SET	RINSE AID SET	SERVICE TEST	END TEST
P(dec.) + Delay(inc.) for 3"	1/2 + Delay for 3"	1/2 for 3"(ion)	open door, switch on + Opt. for 5"	-	-	open door, switch on + P for 3"	open door, switch on + P for 5"	open door, switch on + P for 8"	close door, switch on + P for 3"

11G--11A, 11R--11K 45 cm (ASYNCHRONOUS W/O DIVERTER, Converted Model: D22, D32 45 cm)

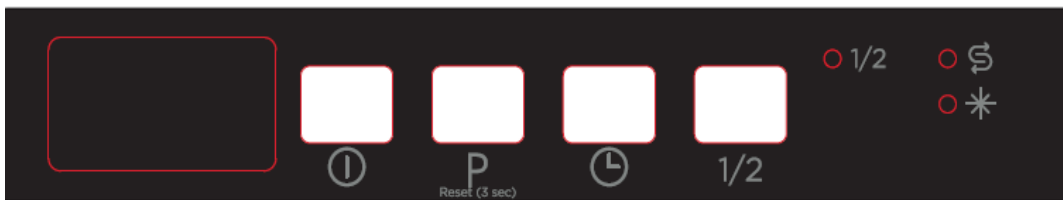

Child lock	ION	UVON	Triple&Direct W.	Auto door	Water box	-
IL 2.1	Inner Light	Aquazone	Turbidity			OPTIONAL
Buzzer						DEFAULT

Secret Combinations

VOICE SETUP	INNER LIGHT	ION	ADO CONTROL	BLDC CONTROL	W.SAVE CONTROL	SALT SET	RINSE AID SET	SERVICE TEST	END TEST
P(dec.) + Delay(inc.) for 3"	Delay + 1/2 for 3"	1/2 for 3"(ion)	-	-	-	open door, switch on + P for 3"	open door, switch on + P for 5"	open door, switch on + P for 8"	close door, switch on + P for 3"

I23-I22-I21, 11M-I2L-I2K 60 cm (ASYNCHRONOUS W DIVERTER, Converted Model: D41)



Child lock	UVON	Auto door	Water box	-
IL 2.1	Inner light	Turbidity (I23 model default)	Triple&Direct W.	ION
Buzzer				OPTIONAL
				DEFAULT

Secret Combinations

VOICE SETUP	INNER LIGHT	ION	ADO CONTROL	BLDC CONTROL	W.SAVE CONTROL	SALT SET	RINSE AID SET	SERVICE TEST	END TEST
Delay(dec.) + Options(inc.) 3"	1/2 + Delay 3"	1/2 for 3"(ion)	-	-	-	open door, switch on + P for 3"	open door, switch on + P for 5"	open door, switch on + P for 8"	close door, switch on + P for 3"

I23-I22-I21 45 cm (ASYNCHRONOUS W DIVERTER, Converted Model: D41 45cm)

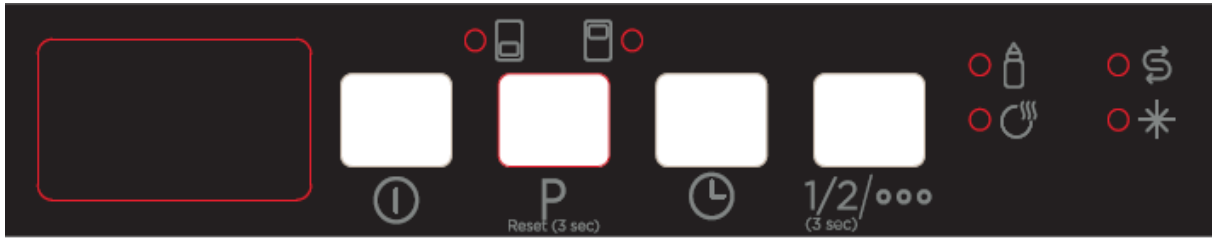

Child lock	UVON	Auto door	Water box	-	
IL 2.1	Inner Light	Triple&Direct W.	Turbidity (I23 model default)	ION	OPTIONAL
Buzzer				DEFAULT	

Secret Combinations

VOICE SETUP	INNER LIGHT	ION	ADO CONTROL	BLDC CONTROL	W.SAVE CONTROL	SALT SET	RINSE AID SET	SERVICE TEST	END TEST
P(dec.) + Delay(inc.) for 3"	Delay + 1/2 for 3"	P + 1/2 for 3"(ion)	-	-	-	open door, switch on + P for 3"	open door, switch on + P for 5"	open door, switch on + P for 8"	close door, switch on + P for 3"

I24, I2N 60 cm (BLDC, Converted Model: D43)



Child lock	Water box				-	
IL 2.1	ION	UVON	Inner Light	Auto door	Triple&Direct W.	OPTIONAL
Buzzer	Turbidity				DEFAULT	

Secret Combinations

VOICE SETUP	INNER LIGHT	ION-UVON	ADO CONTROL	BLDC CONTROL	W.SAVE CONTROL	SALT SET	RINSE AID SET	SERVICE TEST	END TEST
Delay(dec.) + Options(inc.) 3"	1/2 + Delay 3"	1/2 for 3"(ion) 6"(UV)	open door, switch on + Opt. for 5"	open door, switch on + (1/2 + Opt.) for 5", 1/2(dec.), Opt.(inc.)	-	open door, switch on + P for 3"	open door, switch on + P for 5"	open door, switch on + P for 8"	close door, switch on + P for 3"

124 45 cm (BLDC, Converted Model: D43 45 cm)

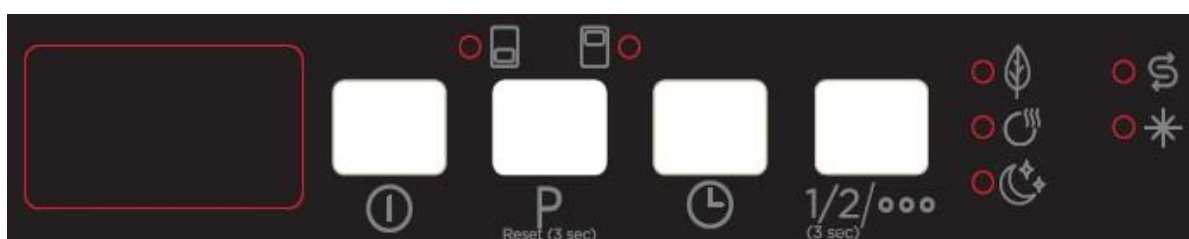

Child lock	Water box							-	
IL 2.1	ION	UVON	Inner Light	Auto door	Triple&Direct W.	OPTIONAL			
Buzzer	Turbidity							DEFAULT	

Secret Combinations

VOICE SETUP	INNER LIGHT	ION-UVON	ADO CONTROL	BLDC CONTROL	W.SAVE CONTROL	SALT SET	RINSE AID SET	SERVICE TEST	END TEST
P(dec.) + Delay(inc.) for 3"	Delay + 1/2 for 3"	P + 1/2 for 3"(ion) 6"(UV)	open door, 1/2 + switch on + 1/2 for 5"	open door, (Delay + 1/2) + switch on + (Delay + 1/2) for 5", Delay(dec.), 1/2 (inc.)	-	open door, switch on + P for 3"	open door, switch on + P for 5"	open door, switch on + P for 8"	close door, switch on + P for 3"

I25, I2O 60 cm (BLDC, Converted Model: D45)



Child lock						-
IL 2.1	ION	UVON	Inner Light	Auto door	Triple&Direct W.	OPTIONAL
Buzzer	Water box	Turbidity				DEFAULT

Secret Combinations

VOICE SETUP	INNER LIGHT	ION-UVON	ADO CONTROL	BLDC CONTROL	W.SAVE CONTROL	SALT SET	RINSE AID SET	SERVICE TEST	END TEST
Delay(dec.) + Options(inc.) 3"	1/2 + Delay 3"	1/2 for 3"(ion) 6"(UV)	open door, switch on + Opt. for 5"	open door, switch on + (1/2 + Opt.) for 5", 1/2(dec.), Opt.(inc.)	open door, switch on + (P + 1/2) for 5"	open door, switch on + P for 3"	open door, switch on + P for 5"	open door, switch on + P for 8"	close door, switch on + P for 3"

I26---I29, I2X, I2P---I2T, I2U 60 cm (BLDC, Converted Model: D46)



Child lock	Auto door	Water box				-
IL 2.1	ION	UVON	Inner Light	Triple&Direct W.	OPTIONAL	
Buzzer	Turbidity				DEFAULT	

Secret Combinations

VOICE SETUP	INNER LIGHT	ION-UVON	ADO CONTROL	BLDC CONTROL	W.SAVE CONTROL	SALT SET	RINSE AID SET	SERVICE TEST	END TEST
Delay(dec.) + Options(inc.) 3"	1/2 + Delay 3"	1/2 for 3"(ion) 6"(UV)	-	open door, switch on + (1/2 + Opt.) for 5", 1/2(dec.), Opt.(inc.)	-	open door, switch on + P for 3"	open door, switch on + P for 5"	open door, switch on + P for 8"	close door, switch on + P for 3"

I51 45, 60 cm (ASYNCHRONOUS W/O DIVERTER, Converted Model: D51)



Child lock		UVON	Auto door	Water box	Triple&Direct W.	-
IL 2.1	Aquazone	Inner Light	ION			OPTIONAL
Buzzer	Turbidity					DEFAULT

Secret Combinations

VOICE SETUP	INNER LIGHT	ION	ADO CONTROL	BLDC CONTROL	W.SAVE CONTROL	SALT SET	RINSE AID SET	SERVICE TEST	END TEST
Dry(dec.) + HL(inc.) 3"	Delay + Dry 3"	HL for 3"(ion)	-	-	-	open door, switch on + P for 3"	open door, switch on + P for 5"	open door, switch on + P for 8"	close door, switch on + P for 3"

I53-I52 45, 60 cm (ASYNCHRONOUS W DIVERTER, Converted Model: D52)



Child lock	UVON	Auto door	Water box	-
IL 2.1	Inner Light	Triple&Direct W.	ION	OPTIONAL
Buzzer	Turbidity (152 modelde ops)			DEFAULT

Secret Combinations

VOICE SETUP	INNER LIGHT	ION	ADO CONTROL	BLDC CONTROL	W.SAVE CONTROL	SALT SET	RINSE AID SET	SERVICE TEST	END TEST
Dry/Rinse(dec.) + HL(inc.) 3"	Delay + Dry/Rinse 3"	HL for 3"(ion)	-	-	-	open door, switch on + P for 3"	open door, switch on + P for 5"	open door, switch on + P for 8"	close door, switch on + P for 3"

154 45, 60 cm (BLDC, Converted Model: D53)



Child lock	Water box				-
IL 2.1	ION	UVON	Inner Light	Triple&Direct W.	OPTIONAL
Buzzer	Turbidity	Auto door			DEFAULT

Secret Combinations

VOICE SETUP	INNER LIGHT	ION-UVON	ADO CONTROL	BLDC CONTROL	W.SAVE CONTROL	SALT SET	RINSE AID SET	SERVICE TEST	END TEST
Dry/E.save(dec.) + HL(inc.) 3"	Delay + Dry/E.save 3"	HL for 3"(ion) 6"(UV)	open door, Dry + switch on + Dry for 5"	open door, HL + switch on + HL for 5", Dry(dec.), Silent(inc.)	-	open door, switch on + P for 3"	open door, switch on + P for 5"	open door, switch on + P for 8"	close door, switch on + P for 3"

155 60 cm (BLDC, Converted Model: D55)



Child lock					-
IL 2.1	ION	UVON	Inner Light	Triple&Direct W.	OPTIONAL
Buzzer	Turbidity	Auto door	Water box		DEFAULT

Secret Combinations

VOICE SETUP	INNER LIGHT	ION-UVON	ADO CONTROL	BLDC CONTROL	W.SAVE CONTROL	SALT SET	RINSE AID SET	SERVICE TEST	END TEST
Dry/E.save(dec.) + HL(inc.) 3"	Delay + Dry/E.save 3"	HL for 3"(ion) 6"(UV)	open door, Dry + switch on + Dry for 5"	open door, HL + switch on + HL for 5", Dry(dec.), Silent(inc.)	open door, Silent + switch on + Silent for 5"	open door, switch on + P for 3"	open door, switch on + P for 5"	open door, switch on + P for 8"	close door, switch on + P for 3"

I59...-I56, I5X 60 cm (BLDC, Converted Model: D56)



Child lock	Auto door	Water box				-
IL 2.1	ION	UVON	Inner Light	Triple&Direct W.	OPTIONAL	
Buzzer	Turbidity					DEFAULT

Secret Combinations

VOICE SETUP	INNER LIGHT	ION-UVON	ADO CONTROL	BLDC CONTROL	W.SAVE CONTROL	SALT SET	RINSE AID SET	SERVICE TEST	END TEST
Dry(dec.) + HL(inc.) 3"	Delay + Dry 3"	HL for 3"(ion) 6"(UV)	-	open door, HL + switch on + HL for 5", Dry(dec.), Silent(inc.)	-	open door, switch on + P for 3"	open door, switch on + P for 5"	open door, switch on + P for 8"	close door, switch on + P for 3"

ELECTRICAL COMPONENTS

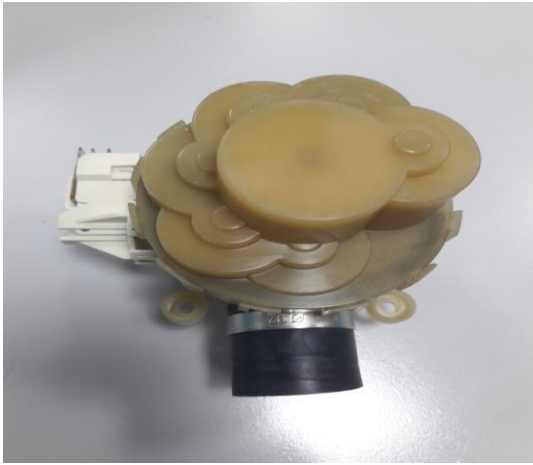

AQUAZONE

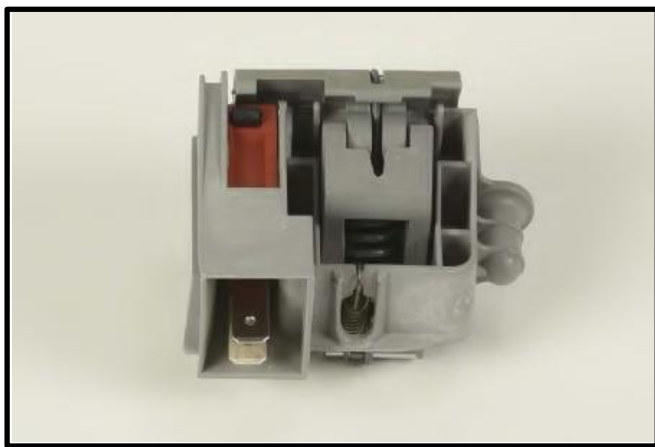

DOOR LOCK

It is a mechanical lock/release system that is closing the door, supplying the connection of electrical parts in the machine and cutting off the connection.

Currency 16 (4) A

CIRCULATION PUMP

Voltage	220/240
Frequency	50HZ
Total Power	90W
Coil Isolation Class	F
Thermal Protector	150°C
Pump Outlet Pressure	300mbar
Pump Flowrate	60 lt/min

Measurement of the primary windings of the washing pump. (118.2-135.9 Ω)

Measurement of the secondary windings of the washing pump (white cable – blue cable)(117.9-135.6 Ω)

Single direction, single phase, asynchronous and two pole.

It turns opposite clock direction.

It is assambled to the basement with rubber hangers.



FLOATER

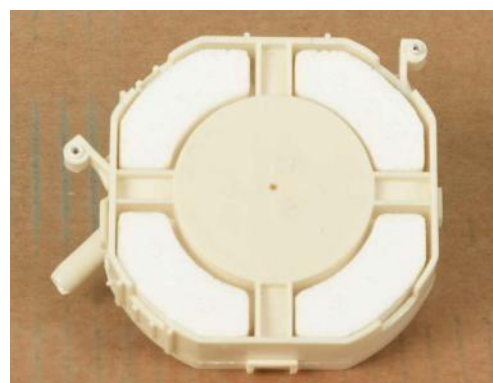

CAPACITOR

2,5 μ F - 450 V class S2

Capacitor is permanently connected to the circulation pump coils.



DRAIN PUMP



Voltage	220/240 volt
Frequency	50Hz
Flowrate	30W
Coil Resistance / Hanyu	220 Ω % \pm 7
Coil Resistance / Leili	141 Ω % \pm 7
Coil Isolation Class	F
Thermal Protector	120 $^{\circ}$ C

HEATER

Voltage 220/240 volt
Total power 1800W

27.6-30.6 ohm

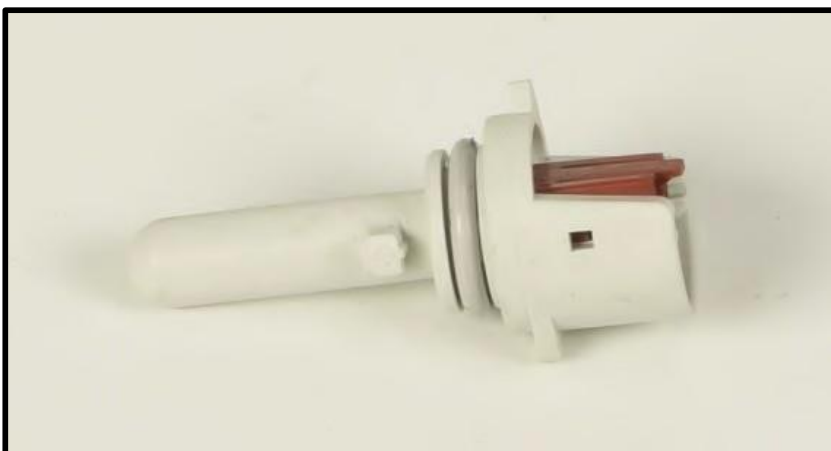

NTC

+25 $^{\circ}$ C	-	47.200	\pm	850	Ω
+30 $^{\circ}$ C	-	37.500	\pm	675	Ω
+40 $^{\circ}$ C	-	24.900	\pm	349	Ω
+50 $^{\circ}$ C	-	17.000	\pm	170	Ω
+60 $^{\circ}$ C	-	11.700	\pm	117	Ω
+70 $^{\circ}$ C	-	8.280	\pm	108	Ω
+80 $^{\circ}$ C	-	5.945	\pm	101	Ω

		C	T		
PRESSURE SWITCH	CN2.10 - CN2.2	0 Ω ∞Ω	KN2.9 - KN2.10	0 Ω ∞Ω	WATER NO WATER

PRESSURE SWITCH

Voltage 220/240 v

Frequency 50/60 Hz

16 A - 3 Pins

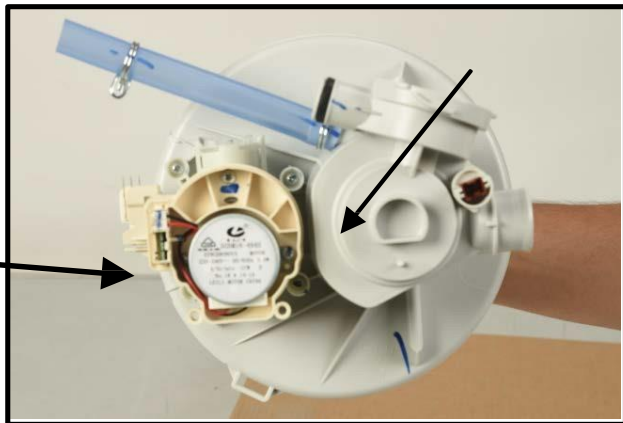
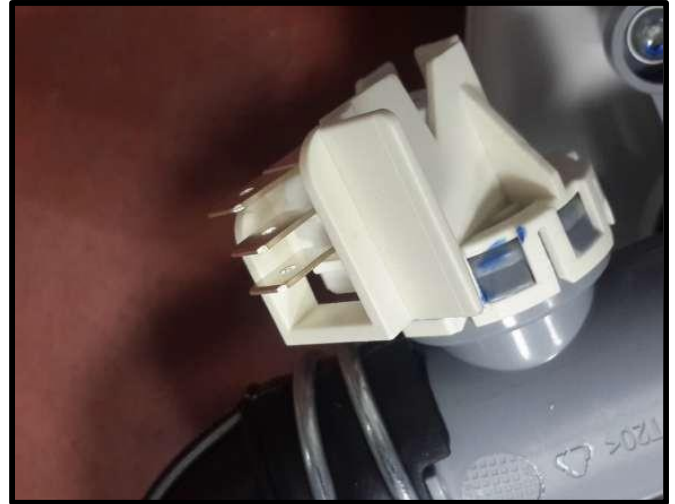

DIVERTER

There is diverter at A15 and A23 models It is assembled to the heater Casing Group.

Voltage	220/240 V
Frequency	50 Hz
Power	8W
Resistance	10500 ± %5 Ω

WATER INLET VALVE

Single inlet and single outlet standard single coil selenoid valve.

Voltage	220 - 240
Total Power	6W
Flowrate	2,5 ±% 15 lt/dk
Coil Isolation Class	H
Resistance	4200 ±%10

It is assembled to the basement and connect to the airbreak by hose.



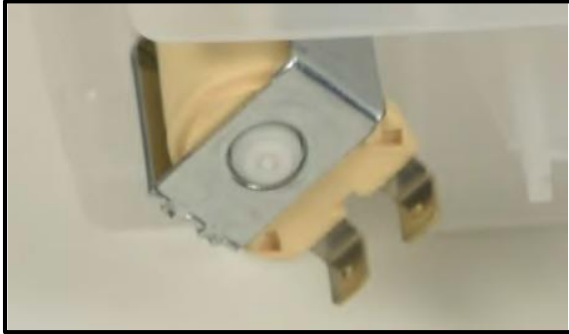
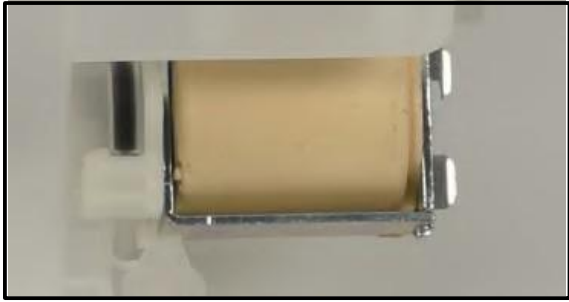

REGENERATION VALVE

Voltage	220/240 V
Frequency	50/60 Hz
Total power	6 W
Resistance	$3560 \pm \% 10 \Omega^{\circ}\text{C}$

Regeneration valve is assembled on the water softener.

PARASITE FILTER

Voltage	220/240
Frequency	50/60 Hz

$0,1 \mu\text{F (X1)} + 2 \times 2,2 \mu\text{F (Y2)} + 1\text{M}\Omega$

It is used to prevent parasites from the main supply It has been assembled to basement.

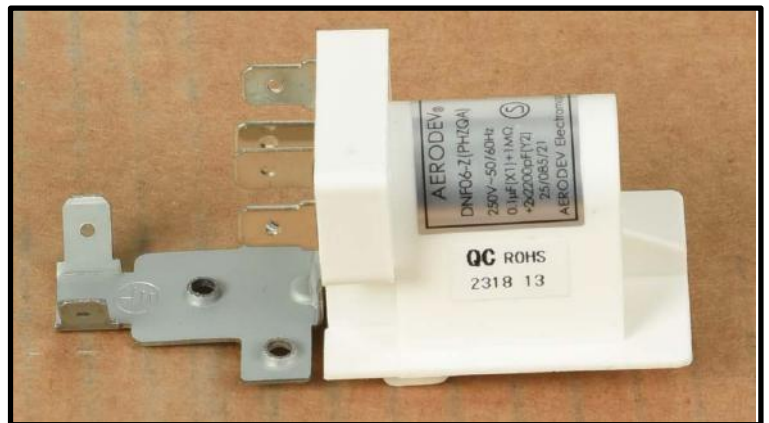

TURBO FAN MOTOR

There is a thermal protector shaded pole motor, two pole temperature is between $-40-150^{\circ}\text{C}$

There is turbo fan motor only at A models.

SALT SENSOR



Voltage 250 V
 Currency 50 mA

It is assembled to the water softener. It warns if the salt is less than requested quantity.

POWER CORD

Type	Euro 3'lü 1mm ² , copper conducting
Isolation	TS 9760 HO 5VV - F
Plug	TS - IEC 60884 - 1 PVC injected
Length	1650 mm

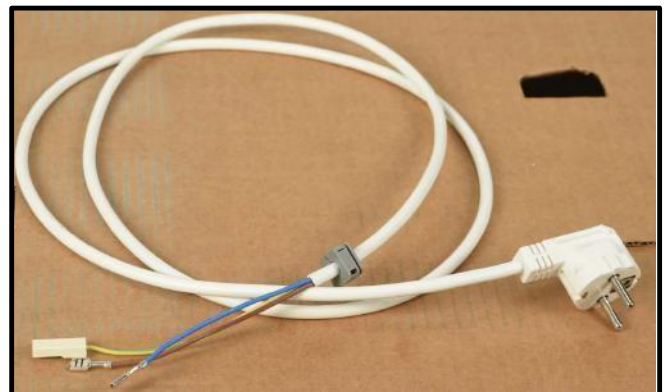

DRAIN HOSE



Drain hose maximum height	110 cm
Drain hose minimum height	50 cm
Drain hose maximum lenght	400 cm
Total Power	15 W
Voltage	220/240 V
Frequency	50 Hz
Resistance	238.6± %5 Ω

FAILURE CODES (Possible Problems)

F1 (ALARM IS ACTIVE FOR OVERFLOW)

FLOATER

- Floater switch can be out of order or have a problem with the cable connection.

TUB

- There can be a water leakage from the tub

ELECTRONIC CARD

- Electronic card can be out of order.

F2 (THE WASTE WATER IN THE MACHINE CANNOT BE DISCHARGED)

Drain hose

- Water outlet hose is clogged
- Check of the water outlet hose position.

Drain pump

- Check the drain pump resistance and power values
- There can be a problem with cable connection of the drain

Pressure switch

- Pressure switch of the heater casing group can have a mechanical or cable connection problem.

F3 (ERROR OF CONTINUOUS WATER INPUT)

Water inlet valve

- Water inlet valve can be out of order or can not be closed.

Electronic card

- Electronic card can be out of order.

F4 (FLOWMETER FAULTY)

Flowmeter

- Flowmeter can be out of order.
- Cable connection of flowmeter can be faulty.

Electronic card

- Electronic card can be out of order.

F5 (INADEQUATE WATER SUPPLY)

Water tap

- Make sure the water input tap is totally open and that there is no water cut.

Water inlet hose

- Close the water input tap, separate the water input hose from the tap and clean the filter at the connection end of the hose.

Water inlet valve

- Water inlet valve filter can be clogged.
- Water inlet valve can be out of order. There can be a problem with the cable connection of water inlet valve.

Floater

- Floater switch can be out of order or have a problem with the cable connection.

Pressure switch

- Pressure switch of the heater can have a mechanical or cable connection problem.

Circulation pump

- Circulation pump can be out of order or have a problem with the cable connection. External part can be blocked to the circulation pump.

F6 (NTC FAULTY)

Ntc

- Ntc can be out of order.
- Ntc cable connection can be faulty. Ntc can be short or open circuit.

Electronic card

- Check the power and resistance value of heater.
- Check the cable connection of the heater.
- There may be an explosion in the NTC triac region on the electronic card.
- The electronic card may be deformed.

CABLE HARNESS

- There may be a problem caused by the disconnection between the cable tree, NTC and electronic board.

NOTE: If the NTC part is faulty, it will not resist in any way.

F7 (EXTREME HEATING UP FAULTY)

Ntc

- If the water temperature inside machine higher than 77°C, ntc can be out of order.

Electronic card

- Electronic card can be out of order.

F8 (INADEQUATE HEAT)

Heater

- Check the power and resistance values.
- Check the cable connection of the heater.

Electronic card

- Check the electronic card

F9 (DIVERTER POSITION PROBLEM)

Diverter

- Check the values of the diverter.
- Check the cable connection of the diverter.

Electronic card

- Check the electronic card

FA (TURBIDITY SENSOR FAULTY)

Turbidity sensor

- There can be some soil around the turbidity sensor.
- Check the cable connection of the turbidity sensor.

Electronic card

- Check the electronic card.

COMPONENT VALUES MEASUREMENT

Precaution: Always remove the plug from the power socket before touching internal components.

WASHING PUMP:

From the electrical card:

You can only measure the primary winding value from the electrical card. Resistance value of the primary winding must be

	C	T	
CIRCULATIONPUMP	CN2.3 - CN2.9	KN2.3- KN 2.8	Primary winding Secondary winding (from the component)

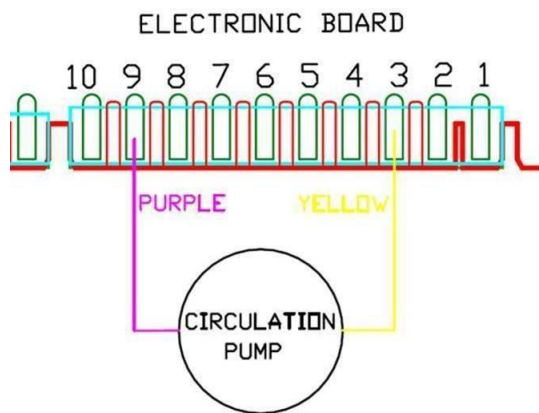

Above sketch show the connectors of the washing pump on the electrical card. Probes of the tester should be applied on to the related connectors.

From the component:



Measurement of the primary windings of the washing pump. (118.2-135.9 Ω)



Measurement of the secondary windings of the washing pump (white cable – blue cable) (117.9-135.6 Ω)

Probes of the tester should be applied on to the related connectors as shown on the pictures.

RINSE AID SENSOR

From the electrical card:

		C		T	
RINSEAIDSENSOR	CN 5.3- CN 5.2	0Ω NO RINSE AID ∞Ω THERE IS RINSE AID	KN 50.8- KN 50.9	0Ω NO RINSE AID ∞Ω THERE IS RINSE AID	Rinse aid off Rinse aid on

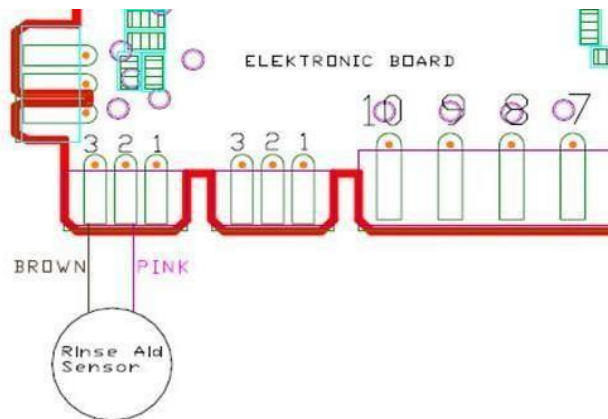

Above sketch shows the connectors of the rinse aid sensor on the electrical card.

From the component:

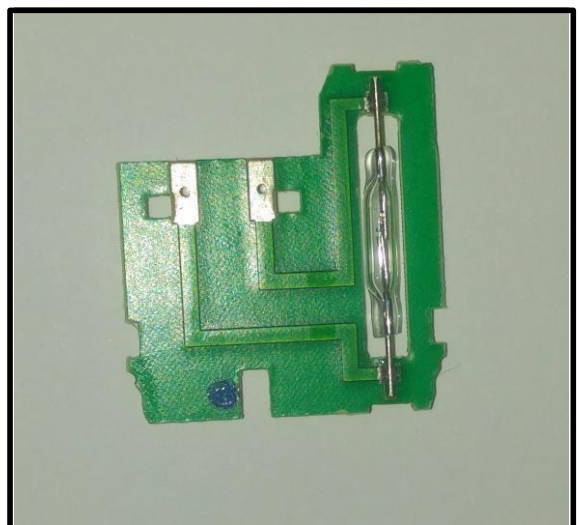
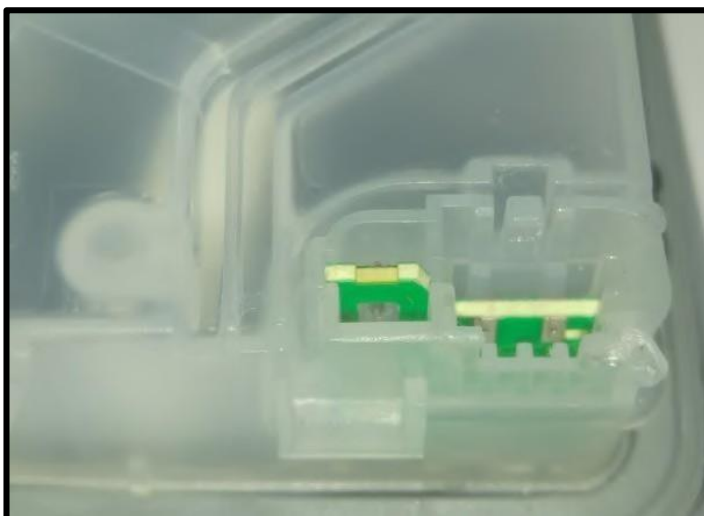

Probes of the tester should be applied on to the related connectors as shown on the pictures.

FAN MOTOR

From the electrical card:

	C	T
FAN MOTOR	CN 6.2 - CN 2.9	KN 6.2 - KN 2.8

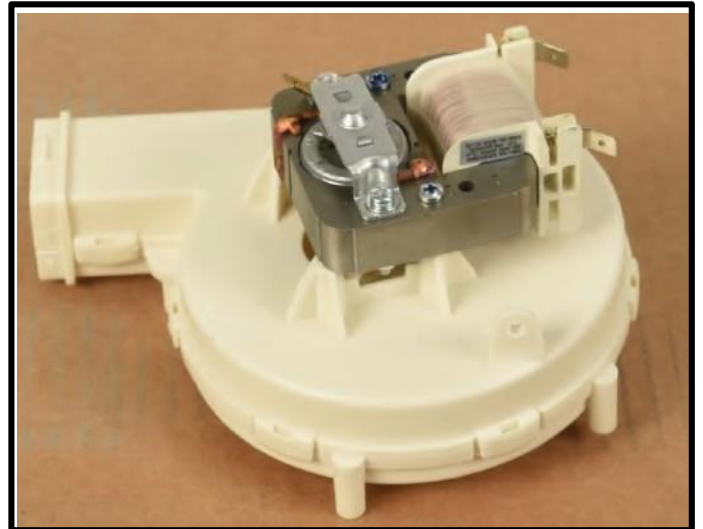
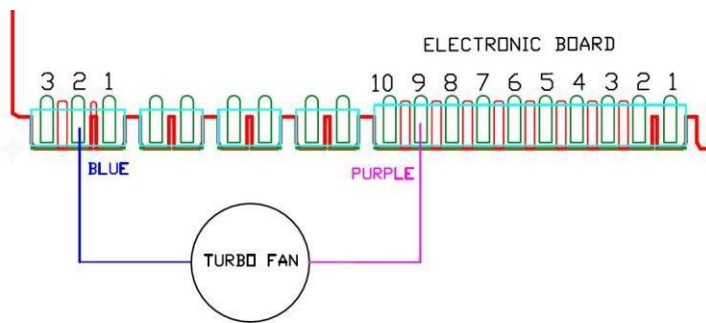

Above sketch shows the connectors of the fan motor on the electronic card.

From the component:



Turbo fan resistance value: $265 \pm 10\% \Omega$ (The resistance of the turbo fan is measured with the resistor switch).

DOOR SWITCH

From the electrical card:

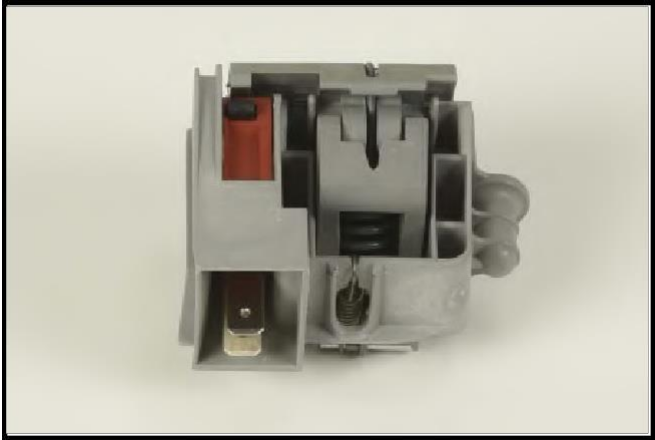
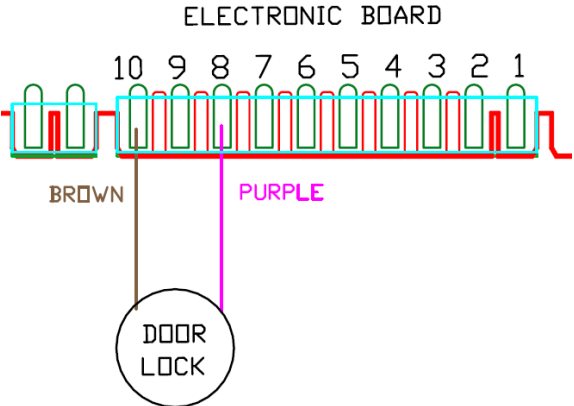

Above sketch show the connectors of the door switch on the electrical card.

From the component:

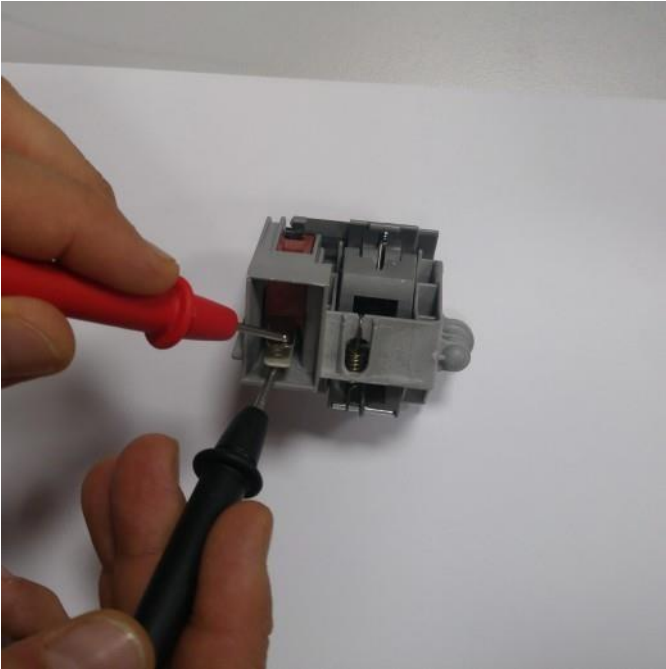

Probes of the tester should be applied on to the related connectors as shown on the pictures.

FLOATER

From the electrical card:

		C		T	
FLOATER(MICROSWITCH)	CN2.1 - CN 2.5 CN2.1 - CN 2.4	0Ω $\infty\Omega$		KN2.5 - KN 2.10 KN2.4 - KN 2.5	0Ω $\infty\Omega$
					Microswitch is inactive (no water) microswitch is active (there is water)

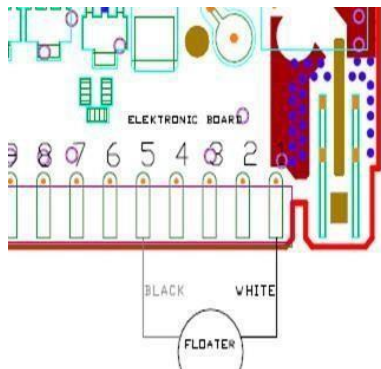
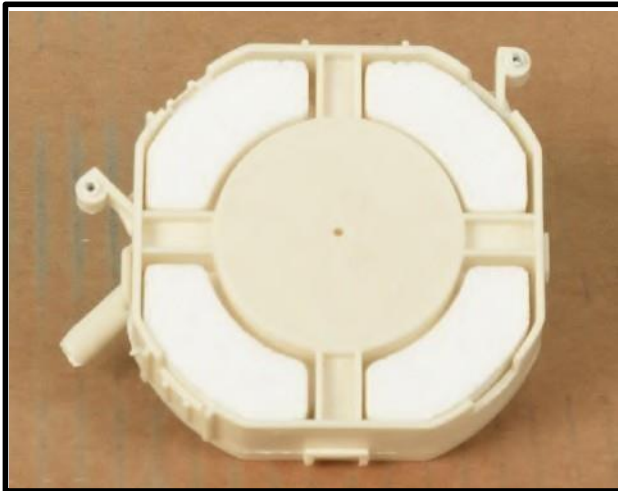

Position 1 : Yo can check the floater by controlling the specified value intervals.

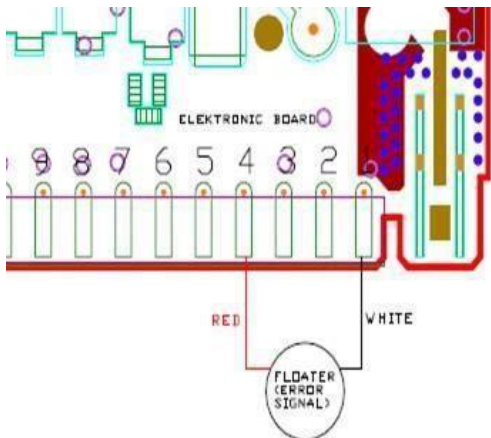

Position 2 : If failure code is occured related with the floater within control the above values: You can figure out whether leakage occurs or not.

SALT SENSOR

From the electrical card:

		C		T	
SALTSSENSOR	CN5.1 - CN5.2	0Ω NO SALT ∞Ω THERE IS SALT	KN50.10- KN 50.11	0Ω NO SALT ∞Ω THERE IS SALT	Measure just on the electronic

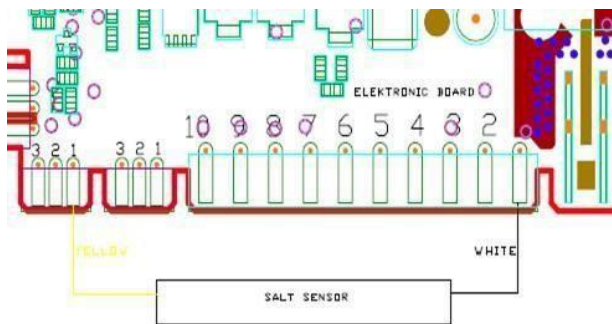

Sketch above show the connectors of the salt sensor on the electronic card. Probes of the tester should be applied on the related connectors.

From the component:



salt sensor can also be measured from the water softener when the salt sensor is assembled on the water softener.

Probes of the tester should be applied on to the related connectors as shown on the pictures.

DIVERTER

From the electrical Card:

	C	T
DIVERTER	CN 6.1 - CN 2.9 10500 ± %7 Ω	KN 6.1 - KN 2.8 10500 ± %7 Ω

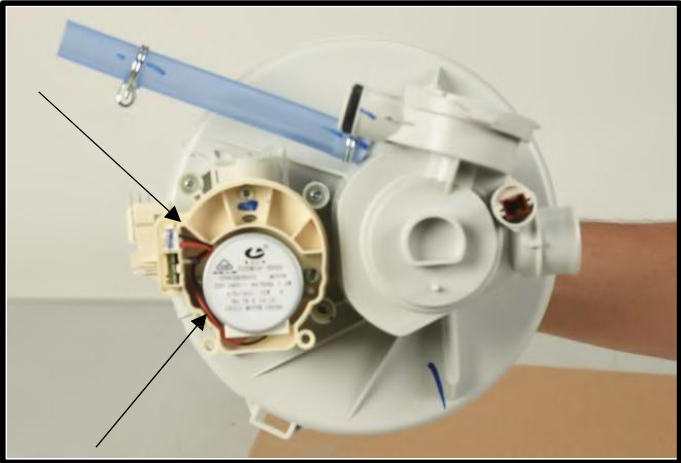
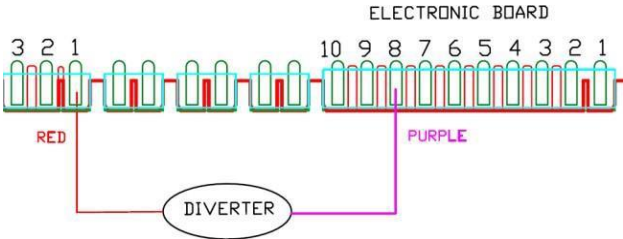

Sketch above show the connectors of the diverter on the electrical card. Probes of the tester should be applied on to the related connectors.

From the component:

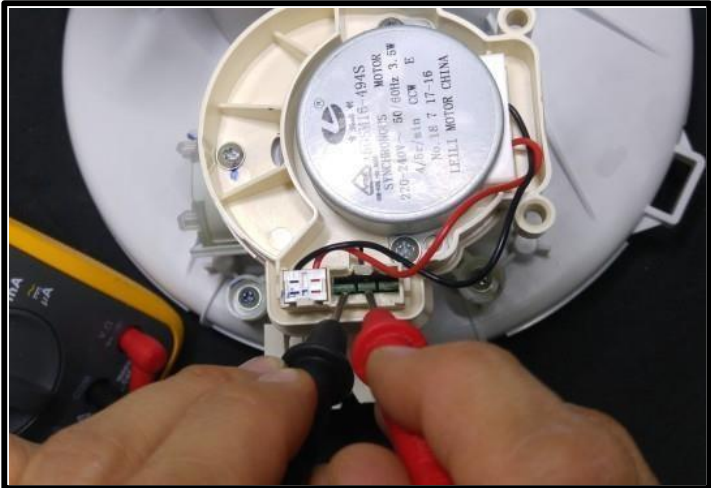

Probes of the tester should be applied on to the related connectors as shown on the pictures.

PRESSURE SWITCH

From the electrical card:

	C	T	
PRESSURE SWITCH	CN2.10- CN2.2	KN2.9- KN2.10	Full fill water no water

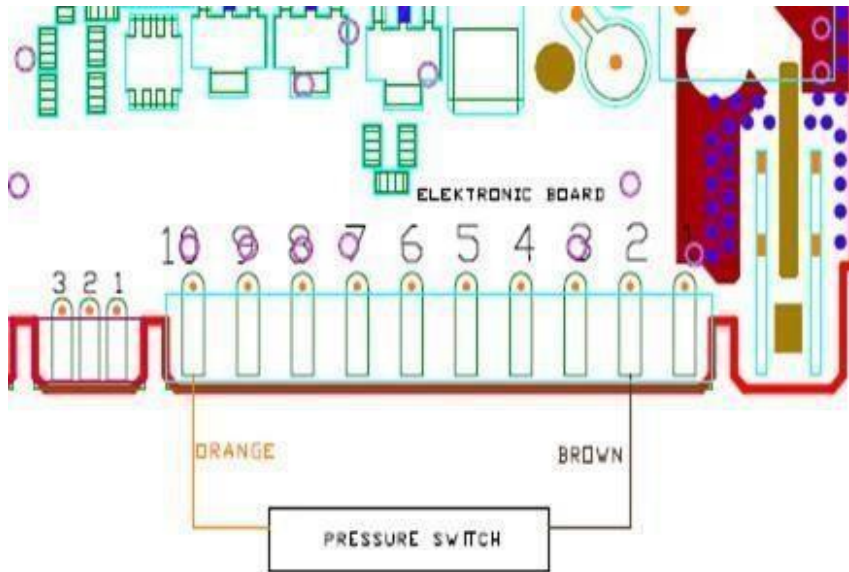

From the component:

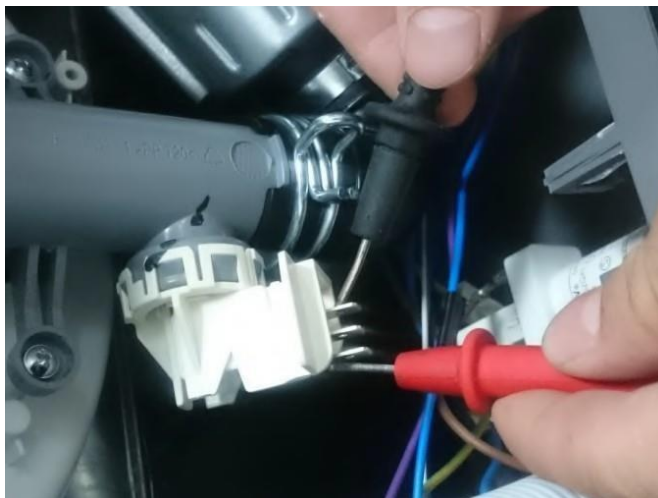

Probes of the tester should be applied on to the related connectors as shown in the picture above.

REGENERATION VALVE

From the electrical Card:

	C	T
REGENERATION VALVE	CN2.2 - CN2.7 3560 Ω ± %10(25°C)	KN2.2 - KN2.10 3560 Ω ± %10(25°C)

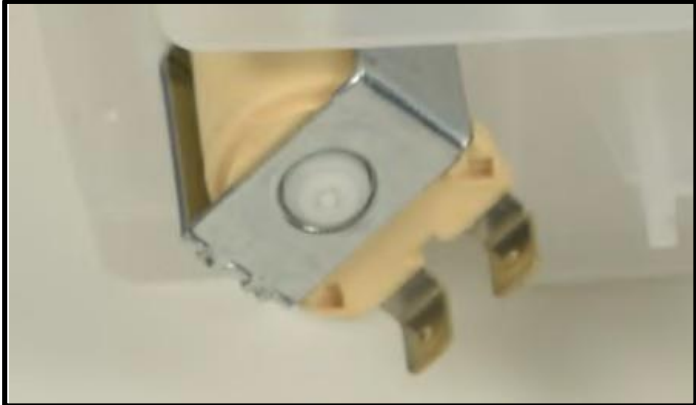
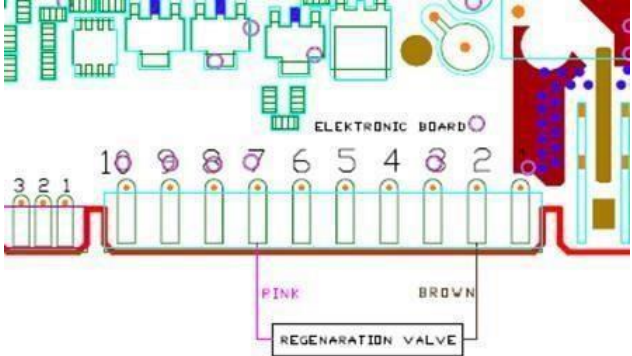
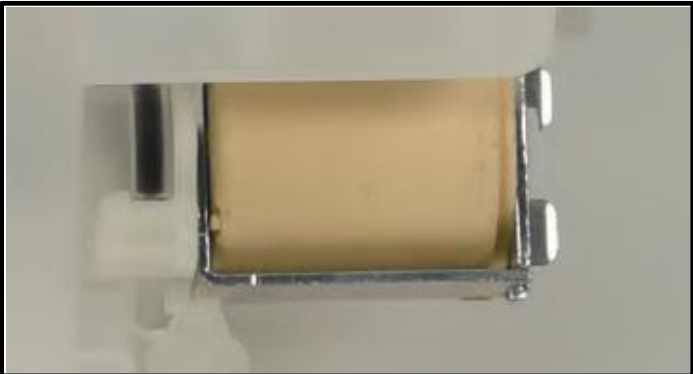

Above sketch show the connectors of the regeneration valve on the electrical card. Probes of the tester should be applied on to the related connectors.

From the component:



HEATER

It can't be measured from the electrical card.

From the component:

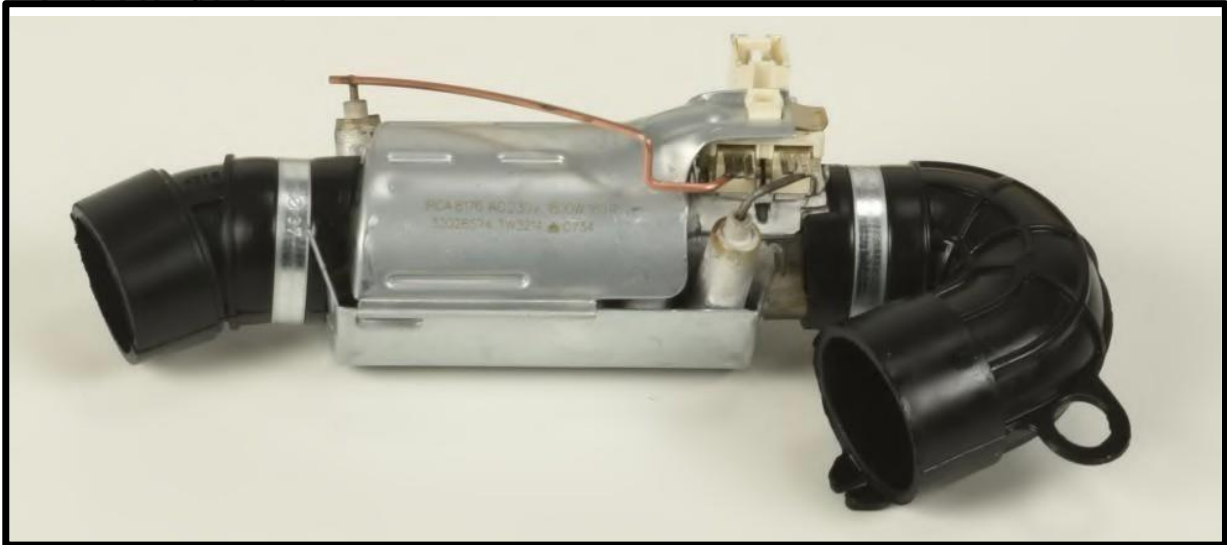

DETERGENT DISPENSER

It can't be measured from the electrical card:

	C	T
DETERGENT DISPENSER	2300Ω ±%10 (25 C°)	2300Ω ±%10 (25 C°)

From the component:

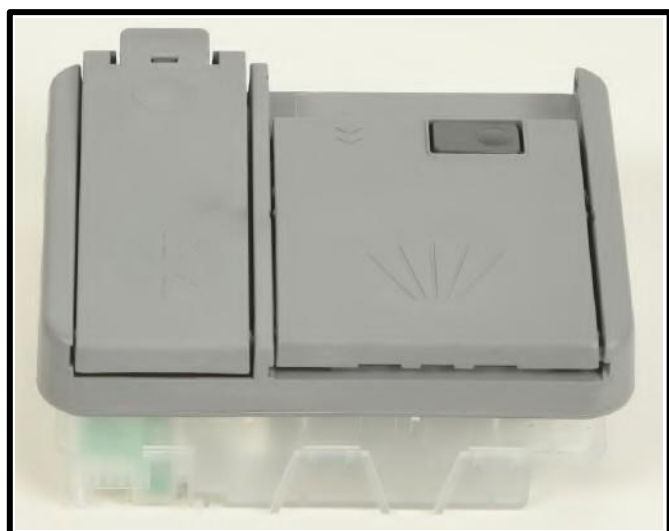

WATER INLET VALVE

From the electrical Card:

	C	T
WATER INLET VALVE	CN2.6 - CN2.9 4200 Ω \pm %10 (20°C)	KN2.6 - KN2.8 4200 Ω \pm %10 (20°C)

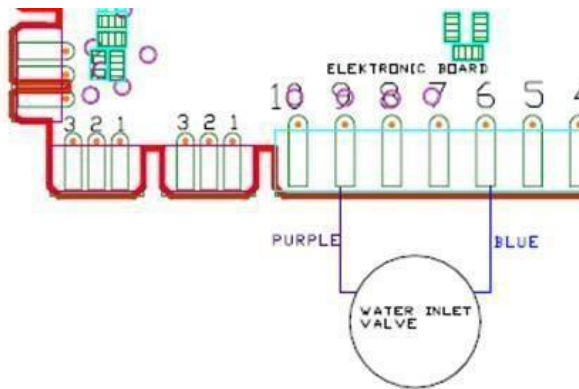

Above sketch show the connectors of the water inlet valve on the electrical card. Probes of the tester should be applied on to the related connectors.

From the component:



Probes of the tester should be applied on to the related connectors as shown on the pictures.

DRAIN PUMP

From the electrical Card:

	C	T
DRAIN PUMP / HANYU	CN2.2 - CN2.4	220 Ω % ±10
DRAIN PUMP / LEILI	CN2.2 - CN2.4	141 Ω % ±10

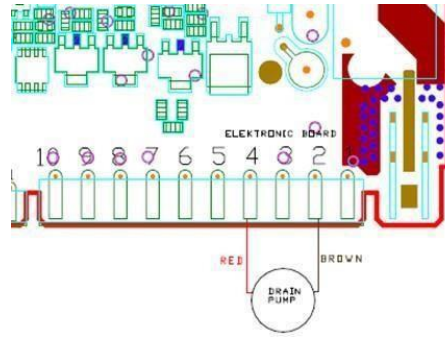

Above sketch show the connectors of the drain pump on the electrical card. Probes of the tester should be applied on to the related connectors.

From the component:



Probes of the tester should be applied on the related connectors as shown on the pictures.

DISASSEMBLY

CAUTION!: REMOVE ELECTRIC PLUG FROM THE SOCKET DURING THE DISASSEMBLY

Top Plate

- a) Remove two screws that fix the top plate at the back.
- b) Push the top-plate back and pull it up.

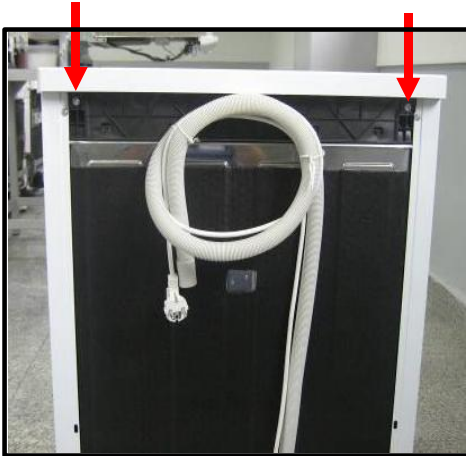

Plastic Kick Plate

- a) Remove two screws fixing plastic kick plate.



- b) Remove the plastic kick plate as it is shown in the picture.



INTERNAL FEEDING TUBES AND SPRAY ARMS REMOVAL

1) Unscrew the feed channel tabs with the help of a screwdriver



2) To assemble, manually narrow the feed channel replacement and insert it into the tabs

3) Pull out the top spray channel by turning it clockwise

4) Turn it counterclockwise to reinstall it

5) To remove the lower spray arm, kindly pull it up



The components that are inside the tub course, micro and metal filters

- a) Open the door.
- b) Remove lower basket
- c) To remove microfilter group rotate them in the direction of counter clockwise and pull them up as it is shown in the picture



- d) To remove microfilter group (course filter and micro filter) pull them as it is shown in the picture.



- e) To remove the metal filter pull it up as it is shown in the picture.



Draining hose



- a) Remove the hose connection plastic.
- b) Remove lower cover.
- c) Remove the clamp that fixes draining hose to the pump
- d) Remove draining hose

Lower basket



- a) Open machine's door.
- b) Pull the basket to yourself.

Upper basket



- a) Open upper basket rail lock front.
- b) Pull the basket to yourself and remove it.



Water Inlet valve

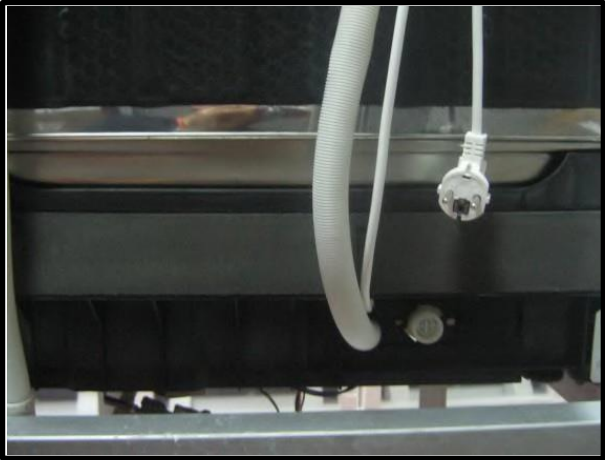

a) Remove lower cover.

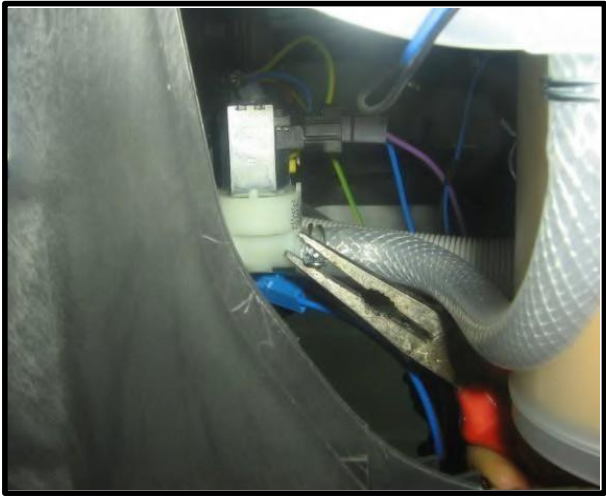

b) Remove the wire that is connected to the water inlet valve.

c) Remove the clamp that connects water inlet valve and air-break as it is shown in the picture

To remove water inlet valve pull it back as it is shown in the direction of picture then release water inlet valve from the pins that is connecte to and rotate it in the direction of counterclockwise.

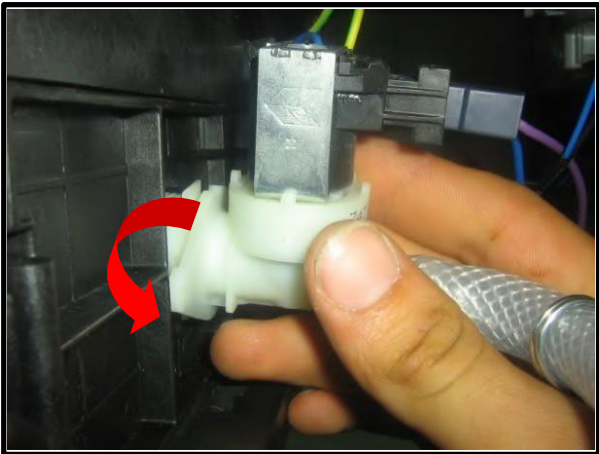

TURBO FAN REMOVAL INSTRUCTIONS

1) Remove top tray



3) Disconnect the condensate unit from the turbo fan.



2) Remove the side panel rear and front screws



side panel rear screw

4) Remove the turbo fan screws



turbo fan screws

5) Disconnect turbo fan cables

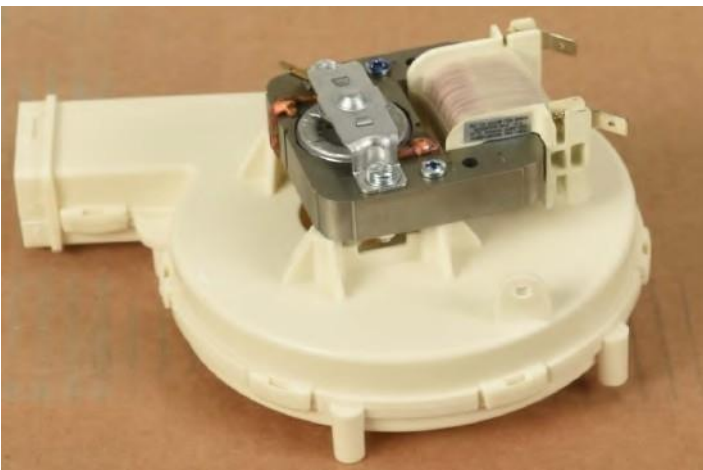

6) Remove the turbo fan from its replacement + to reassemble,
Before connect the cables,
Install the screws,
install the condensate unit

5) Disconnect ntc cables



NTC

6) Disconnect heater hose

7) Unscrew eco or diverter part(it is changeable) screws

8) Then get the sump



To assemble, connect the cables and screws in same way.

SUMP GROUP REMOVAL INSTRUCTIONS

1) Remove 2 screws on top



sump screws

2) Remove the drain pump



drain pump

3) Remove the drain hose



drain hose

4) Remove the blue hose from the water softener to the pool group



blue hose

HEATER REMOVAL INSTRUCTIONS

1) Remove 2 clamps



2) Disconnect cable connections and get the heater



3) To assemble, the cables are connected first and the screws are attached.

Floater



a) Remove lower cover.



b) Remove two screws that fix floater as it is shown in the picture.



c) Remove the two floater hoses.

d) Remove the wire that is connected to the floater.

Water softener



a) To remove salt cup cover, rotate it in the direction of counterclockwise

b) To remove salt cup nut, rotate it in the direction of counterclockwise.

c) Remove left side panel.

d) Derach the connections which are between water softener and air-break.

e) Remove lower cover.

f) Remove the hose that is between sump and salt camp.



Parasite filter



a) Remove lower cover.

b) Remove one screw fixing parasite filter.

c) Remove wires.

d) Push parasite filter and remove it.

DIVERTER REMOVAL INSTRUCTIONS

1) Disconnect the diverter cables



diverter cables

2) Disconnect pressure switch cables

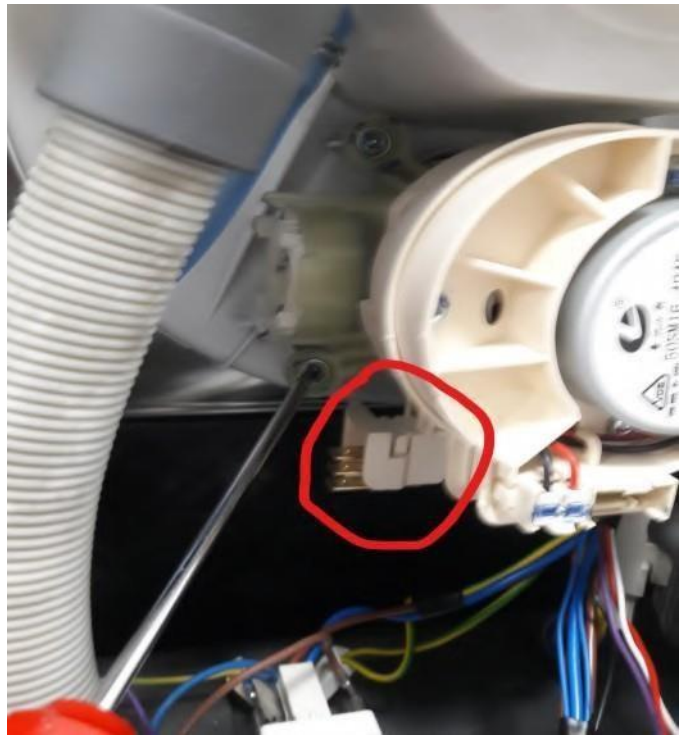

pressure switch

3) Disconnect turbidity sensor cables(if the machine has)

4) Unscrew the diverter screws

5) Pull the clamps with pliers (**Diverter clamp is next to the circulation pump's clamp. you can see in the circulation pump removal instruction page**).

Access the components from the lower cover

a) Lay the appliance on the rear panel.



b) Remove lower cover from the places that are shown in the picture.

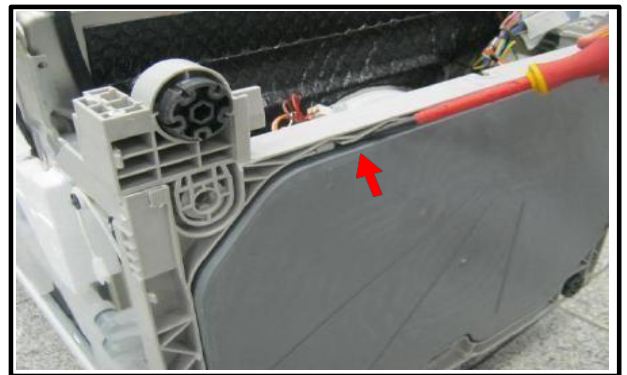

CIRCULATION PUMP REMOVAL INSTRUCTIONS

1) There are 2 clamps.

3) remove the straps from both sides

2) Push the 2 clamps upwards.



pushing the clamps upwards

To access the components from in Front of the Machine



- a) Remove plastic kick plate iron sheet and basement front cover

Regeneration valve

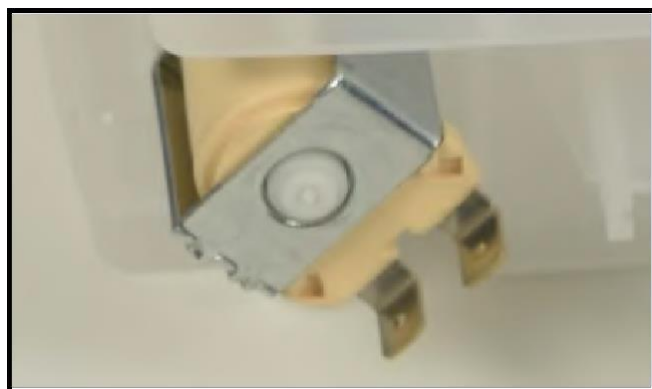

- a) Remove plastic kick plate and kick plate iron sheet.
- b) Remove the wires
- c) To remove regeneration Value rotate counterclockwise and pull it as it is shown in the picture.

Drain pump

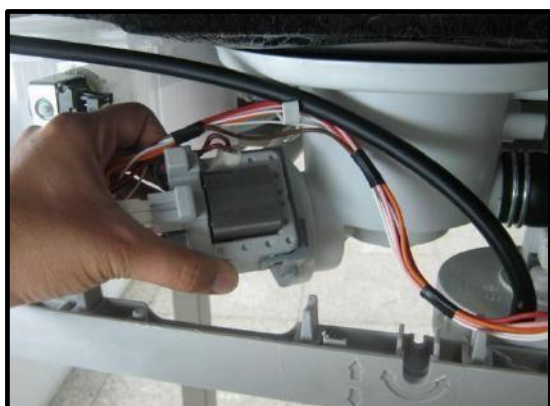

- a) Remove plastic kick plate and kick plate iron sheet
- b) Remove the wires.
- c) To remove the drain pump that fixes to the sump, rotate it in the direction of counterclockwise and pull.

Power cord

- a) Remove hose connection plastic.



- b) Remove the lower cover.
- c) Remove the wires that is between power cord and parasite filter.
- d) Remove the power cord.



Hose connection plastic

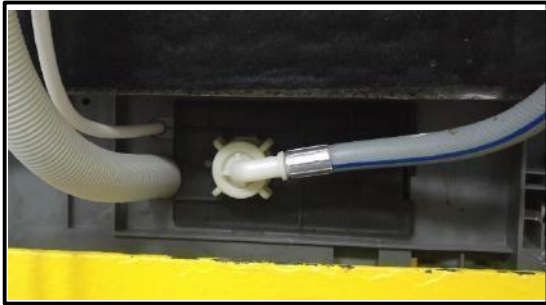

a) Remove left side panel.



b) By using flat tip screwdriver remove hose connection plastic's hinge from the basement as it shown in the picture

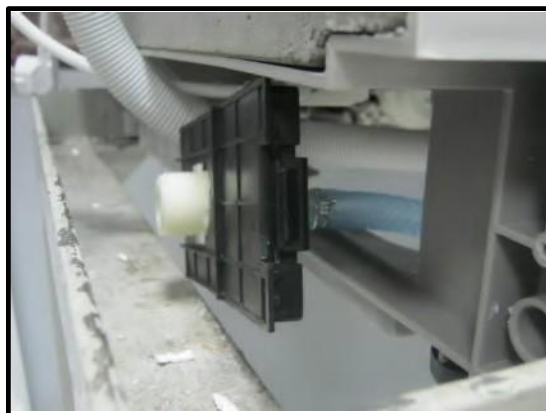

c) Push the hose connection plastic.

Warning: If you do not obey instructions while disassembly of the hose connection plastic it can be broken.

Air - break



a) Remove the left side panel of the machine.

b) Open machine's door

c) Rotate counterclockwise air-break nut and remove it.

d) Remove air-break's connections with salt cap as it is shown in the picture. (be careful about plastic hinges)



Door Inside

- a) Remove side panels.
- b) Remove Hinge Spring.



Door spring

- c) Pull the door inside up as it is shown in the picture.
- d) Remove two screws that fix hinge movement sheet iron to the door inside.



KNOB REMOVAL INSTRUCTIONS



- 1) Remove control panel,
- 2) Remove the pcb box,
- 3) Remove the plastic tabs around the knob by flexing them.

DISPANSER REMOVAL INSTRUCTIONS

1) Remove front panel

2) Disconnect the dispenser cable harness



Dispanser cables

4) Then the dispenser will drop in



dispanser is free

3) Remove the metal tabs on the top, bottom and sides to disengage the dispenser.



metal tabs on the top

5) To assemble, tighten the metal tabs with a pliers

6)

After applying silicone oil or liquid soap to dispenser, press down and engage dispenser.



pressing to the dispanser down

DOOR LOCK REMOVAL INSTRUCTIONS

1) Remove control panel screws



2) Disconnect cable connections with door lock



3) Remove two door lock screws



ELECTRONIC CARD REMOVAL INSTRUCTIONS

1) Remove top tray



3) Remove side panel

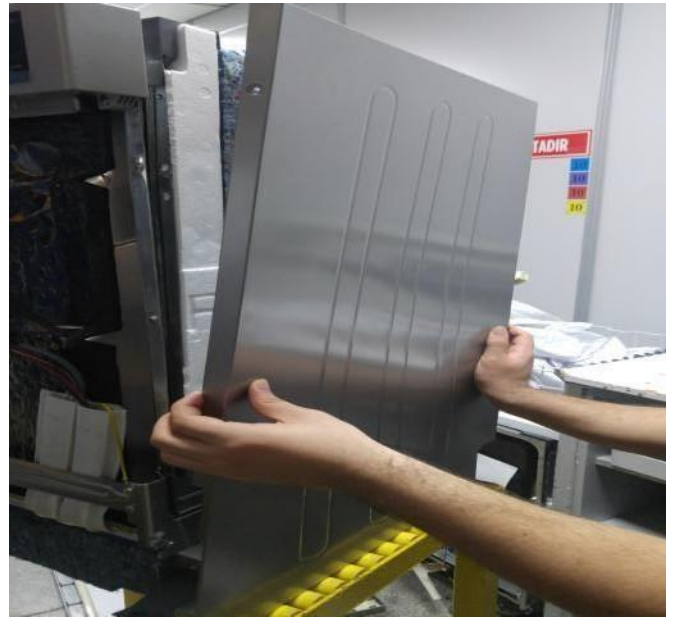

3) Remove side panel support styrofoam

4) Pull up the pcb box



5) Disconnect cable connections from cable harness

6) Remove the tabs and take the electronic card

7) To assemble, reinsert the pcb box into the tabs.

Control Panel

- a) Remove 6 screws that fix control panel to the door inside sheet iron.
- b) Remove the control panel group carefully as shown in the picture

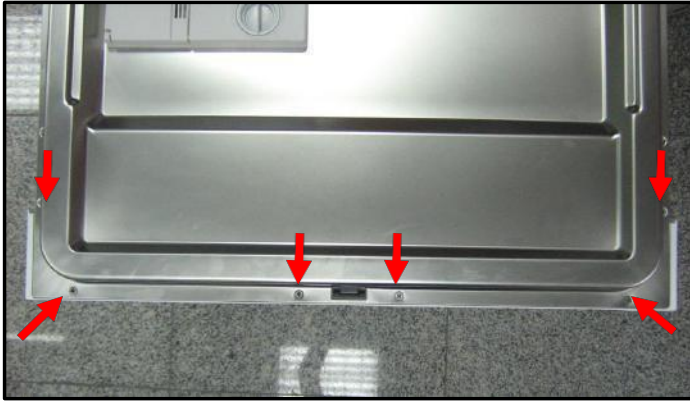

- c) Remove the cable connection plastic which fix cable harness to the control panel as shown in the picture.
- d) Remove the wires that are connected to control panel group.

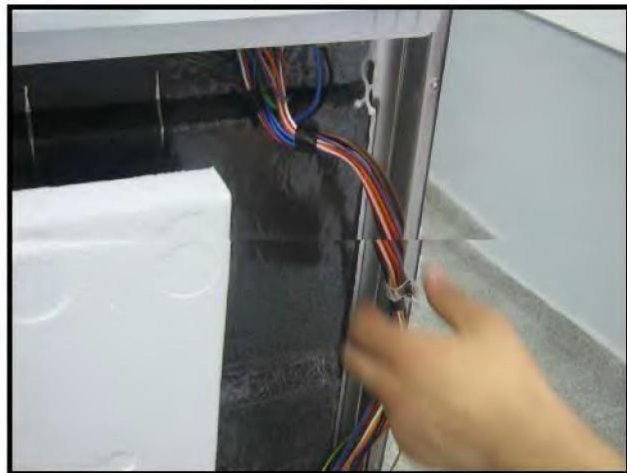

Control Panel

- a) Remove 6 screws that fix control panel to the door inside sheet iron.
- b) Remove the control panel group carefully as shown in the picture

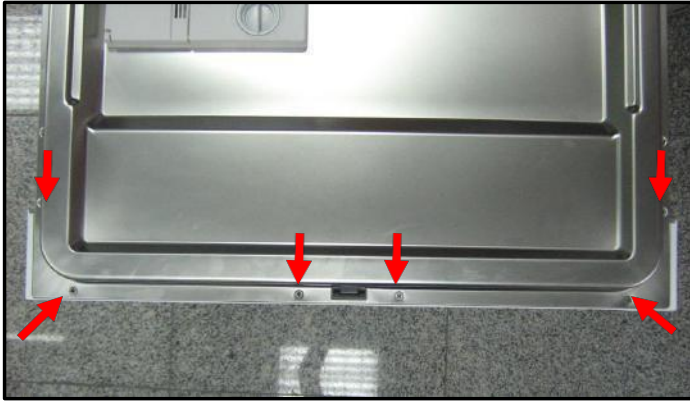

- c) Remove the cable connection plastic which fix cable harness to the control panel as shown in the picture.
- d) Remove the wires that are connected to control panel group.

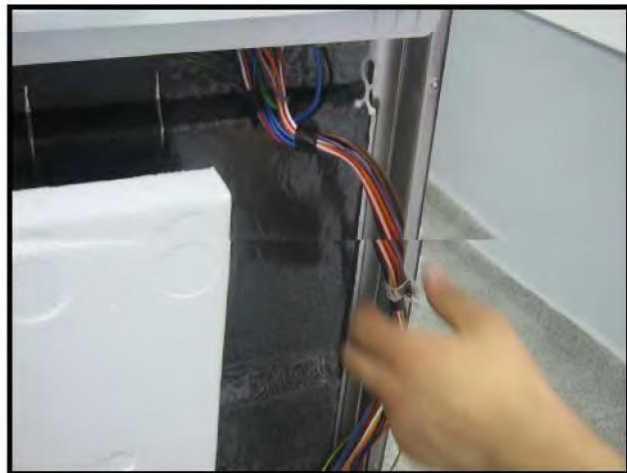

Kick Plate Sheet Iron

- a) Remove top plate, plastic kick plate and side panels.
- b) Remove the screws (4 screws) that fix the kick plate sheet iron.
- c) Pull it down as shown in the picture.



- To remove the side panel, remove the upper plastic hinge and then the above one and pull it up.



Front Panel

a) Remove the screws as it shown in the picture.



b) Pull down the front panel after removing the screws.

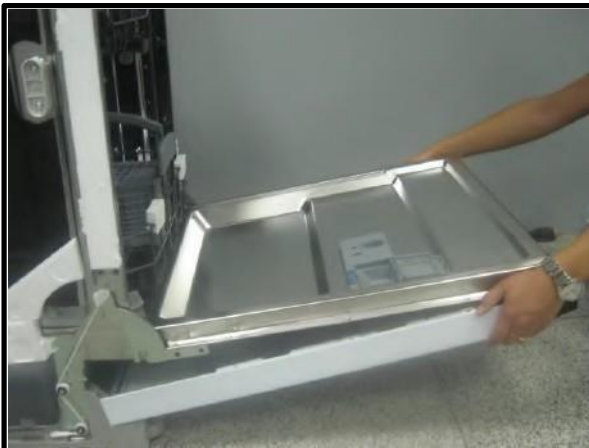

Side panels removal instructions

1) Remove top table screws



Top Tray screws

2) Remove the side panel rear screws



Side panel rear screws

3) Remove the kick plate plastic after removing the front panel



Plastic kick plate screw

4) Remove the side panel front screws



5) remove the side panel rear tabs



6) Remove the side panel front tabs



INNER LIGHT SOURCE REMOVAL INSTRUCTIONS

1) Remove top tray



2) Remove side panel



3) Remove side panel support styrofoam

4) Remove the cables

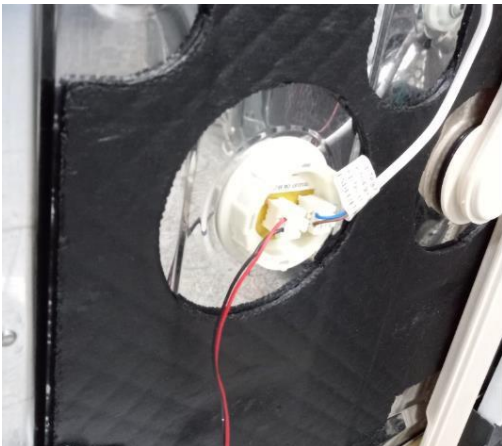

Note: This visual is representative sample

5) Rotate counterclockwise nut and remove it.

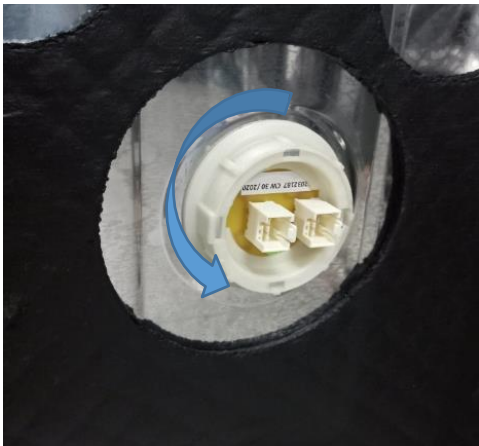

Note: This visual is representative sample.

