

DISHWASHERS

SERVICE MANUAL



SERIES S

TOOLS FOR DISASSEMBLE



Phillips screwdriver

- *All kinds of star-head screws,
- *in the phillips screws of the internal components,



Plier

- *It is used to bend all kinds of sheet metal ends.



Multimeter

- *Resistance values of all kinds of internal components,
- *Electronic card resistors,
- *It is used to measure the resistance of display cards.



Flat Screwdriver

It is used to remove all kinds of aesthetic parts (side panels, front panels and external aesthetic parts of the machine).

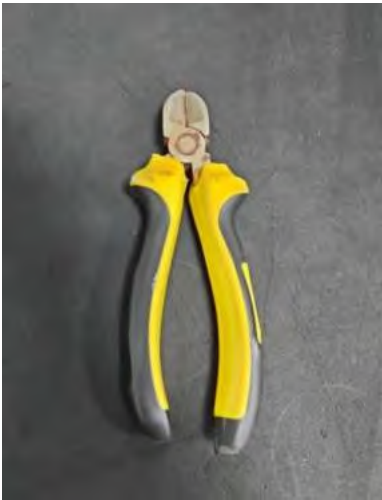

Side Cutter

It is used to cut cables of internal components or any hard part.



Chargeable Drill

It is the most important tool used to remove and install all kinds of screws in the machine.

Contents

S SERIES	1
S SERIES USER INTERFACE PROGRAM AND OPTIONS	8
S series 60 cm program table	8
S series 60 cm option table	10
S series 45 cm program table	12
S series 45 cm option table	13
DISPLAY VIEWS	14
Middle Display	14
Front display	14
60-45 cm S2 Series	15
60 cm S3 Series	15
60 cm Uvli S36-S37-S38-S39	15
45 cm S31-S32-S33	15
45 cm S34	15
45 cm Uvli S34	15
60 cm SA5-SA7	16
60 cm SB5-SB7	16
60 cm SB5_B-SB7_B	16
45 cm SA5-SA7	16
45 cm SB5	16
45 cm SB5_B	16
COMPATIBILITY BETWEEN OPTIONS & PROGRAMS IN EUROPE MODELS	17
COMPATIBILITY BETWEEN OPTIONS IN EUROPE MODELS	18
COMPATIBILITY BETWEEN OPTIONS IN USA MODELS	19
Compatibility of Triple&Direct Option and Programs	19
OPTION DEFINITION	20
Delay Timer	20
Half Load	21
Sanitized Feature(for USA models)	21
MENU SETTINGS	22
HIDDEN MENU SETTINGS	24
ENTERING THE HIDDEN MENU FOR S29	24
ENTERING THE HIDDEN MENU FOR S39	24
Salt-Rinse-Regeneration	29
WATER HARDNESS SET	29
RINSE AID SET	29
REGENERATION CYCLE	30
VOLTAGE SENSE-NTC VALUES	32
Voltage Sensing Control	32

FEATURE OF TIME PHASE.....	32
NTC VALUE S.....	33
STARTING THE PROGRAM	33
OPERATION OF FUNCTIONAL FEATURES	34
Child Lock	34
Ionizer.....	34
Uvon	34
Infoled	36
AUTODOOR OPEN SYTEM	37
AUTODOOR CONTROL TEST	38
For S2x and S3x models:	38
BLDC MOTOR CONTROL TEST	39
To start the BLDC motor test;	39
WATER SAVE CONTROL TEST	40
ERROR DEFINITIONS.....	42
FAILURE ROUTINES.....	48
Failure Routine.....	48
Re-Fill Routine	49
SERVICE TEST	49
SERVICE TEST SPECIFICATIONS.....	51
SELECT SERVICE TEST, CLOSE DOOR WITHOUT PRESSING START/PAUSE BUTTON.....	51
STARTING SERVICE TEST.....	52
OPENING AND CLOSING DOOR DURING SERVICE TEST	52
TERMINATION OF SERVICE TEST(END OF SERVICE TEST)	52
CANCELLING OF A PROGRAM(DURING PROGRAM).....	53
WASHING SPECIFICATIONS AND PROGRAMS	53
OPENING DOOR, SELECTING PROGRAM AND CLOSING DOOR(BEFORE PROGRAM STARTS).....	53
SELECTING AND STARTING PROGRAM AT POWER ON(BEFORE PROGRAM STARTS)	54
OPENING AND CLOSING DOOR DURING PROGRAM(NOT IN DRY STEPS).....	54
OPENING AND CLOSING DOOR DURING PROGRAM (IN DRY STEPS)	54
OPENING AND CLOSING DOOR DURING PROGRAM (IN REGENERATION FIRST STEP)	55
OPENING AND CLOSING DOOR DURING PROGRAM(IN REGENERATION SECOND STEP).....	55
TERMINATION OF A PROGRAM(END OF PROGRAM).....	55
CANCELLING OF A PROGRAM(DURING PROGRAM)	56
SELECTING AND STARTING PROGRAM AT POWER ON WITH START DELAY	56
MODIFICATION OF A PROGRAM WITHOUT RESET	57
MODIFICATION OF A PROGRAM DURING DELAY TIME	58
SWITCH OFF THE MACHINE DURING DELAY TIME.....	59
POWER FAIL	59
TURNING OFF/ON FROM ON/OFF BUTTON.....	59

SOFTWARE REQUIREMENTS	60
HEATER.....	60
WATER FILL.....	60
WATER DRAIN.....	61
Detergent dispenser step.....	61
Rinse aid dispenser step.....	61
AUTOMATIC PROGRAM(TURBIDITY SENSOR)	61
S2 SERIES ASYNCHRONIC CIRCUIT DIAGRAM.....	Hata! Yer işareti tanımlanmamış.
S3 SERIES B CIRCUIT DIAGRAM.....	Hata! Yer işareti tanımlanmamış.
DISASSEMBLY	63
Top Plate	63
Plastic Kick Plate	63
INTERNAL FEEDING TUBES AND SPRAY ARMS REMOVAL	64
Unscrew the feed channel tabs with the help of a screwdriver.....	64
The components that are inside the tub course, micro and metal filters.....	65
Draining hose	98
Lower basket	98
Upper basket	98
Water Inlet valve	99
TURBO FAN REMOVAL INSTRUCTIONS	100
Disconnect ntc cables	101
SUMP GROUP REMOVAL INSTRUCTIONS	102
HEATER REMOVAL INSTRUCTIONS	103
Floater	104
Water softener	105
Parasite filter	105
DIVERTER REMOVAL INSTRUCTIONS	106
Access the components from the lower cover	107
CIRCULATION PUMP REMOVAL INSTRUCTIONS	107
To acces the components from in Front of the Machine.....	108
Regeneration valve.....	108
Drain pump.....	108
Power cord	109
Hose connection plastic.....	110
Air - break	111
Door Inside	112
DISPANSER REMOVAL INSTRUCTIONS	113
DOOR LOCK REMOVAL INSTRUCTIONS	114
ELECTRONIC CARD REMOVAL INSTRUCTIONS	115
Control Panel.....	116

Control Panel	117
Kick Plate Sheet Iron.....	118
Front Panel	119
Side panels removal instructions	120
INNER LIGHT SOURCE REMOVAL INSTRUCTIONS.....	121
OKAM MATTERS TO BE CONSIDERED IN ASSEMBLY OF THE MECHANISM ASSEMBLY.....	122

S SERIES USER INTERFACE PROGRAM AND OPTIONS

S series 60 cm program table

S series 60cm	Size	Motor Type	Electrical Diverter	Total Prg	P1	P2	P3	P4	P5	P6	P7	P8	P9
Model													
S12	60cm	Async.	-	2	Eco	Intensive 65°C or Smart 60°C - 70°C							
S13	60cm	Async.	-	3	Eco	Intensive 65°C or Smart 60°C - 70°C	Super 50' 65°C						
S14	60cm	Async.	-	4	Eco	Intensive 65°C or Smart 60°C - 70°C	Super 50' 65°C	Mini 14'					
S15	60cm	Async.	-	5	Eco	Intensive 65°C or Smart 60°C - 70°C	Super 50' 65°C	Quick 30' 40°C	Mini 14'				
S16	60cm	Async.	-	6	Eco	Intensive 65°C or Smart 60°C - 70°C	Hygiene 70°C	Super 50' 65°C	Quick 30' 40°C	Mini 14'			
S23	60cm	Async.	-	3	Eco	Intensive 65°C or Smart 60°C - 70°C	Self Clean						
S24	60cm	Async.	-	4	Eco	Intensive 65°C or Smart 60°C - 70°C	Super 50' 65°C	Self Clean					
S25	60cm	Async.	-	5	Eco	Intensive 65°C or Smart 60°C - 70°C	Super 50' 65°C	Mini 14'	Self Clean				
S26	60cm	Async.	-	6	Eco	Intensive 65°C or Smart 60°C - 70°C	Super 50' 65°C	Quick 30' 40°C	Mini 14'	Self Clean			
S27	60cm	Async.	-	7	Eco	Intensive 65°C or Smart 60°C - 70°C	Steam Wash	Super 50' 65°C	Quick 30' 40°C	Mini 14'	Self Clean		
S28	60cm	Async.	-	8	Eco	Intensive 65°C or Smart 60°C - 70°C	Steam Wash	Super 50' 65°C	Delicate 40°C	Quick 30' 40°C	Mini 14'	Self Clean	

S29	60cm	Async.	-	9	Eco	Intensive 65°C or Smart 60°C - 70°C	Steam Wash	Super 50' 65°C	Easy Care 60°C	Delicate 40°C	Quick 30' 40°C	Mini 14'	Self Clean
S31	60cm	Async.	Yes	7*	Eco	Intensive 65°C or Smart 60°C - 70°C	Steam Wash	Super 50' 65°C	Quick 30' 40°C (press 2 times for Self Clean)	Mini 14'			
S32	60cm	Async.	Yes	8*	Eco	Intensive 65°C or Smart 60°C - 70°C	Steam Wash	Super 50' 65°C	Delicate 40°C	Quick 30' 40°C (press 2 times for Self Clean)	Mini 14'		
S33	60cm	Async.	Yes	9*	Eco	Smart 60°C - 70°C	Smart 30°C - 50°C	Steam Wash	Super 50' 65°C	Easy Care 60°C	Quick 30' 40°C (press 2 times for Self Clean)	Mini 14'	
S34	60cm	BLDC	Yes	9*	Eco	Intensive 65°C or Smart 60°C - 70°C	Steam Wash	Super 50' 65°C	Easy Care 60°C	Delicate 40°C	Quick 30' 40°C (press 2 times for Self Clean)	Mini 14'	
S36	60cm	BLDC	Yes	7*	Eco	Smart 60°C - 70°C	Steam Wash	Super 50' 65°C	Quick 30' 40°C (press 2 times for Self Clean)	Mini 14'			
S37	60cm	BLDC	Yes	8*	Eco	Smart 60°C - 70°C	Steam Wash	Hygiene 70°C	Super 50' 65°C	Quick 30' 40°C (press 2 times for Self Clean)	Mini 14'		
S38	60cm	BLDC	Yes	9*	Eco	Smart 60°C - 70°C	Steam Wash	Hygiene 70°C	Super 50' 65°C	Dual Pro Wash 60°C	Quick 30' 40°C (press 2 times for Self Clean)	Mini 14'	
S39	60cm	BLDC	Yes	9*	Eco	Smart 60°C - 70°C	Hygiene 70°C	Save+ 5.4 lt	Super 50' 65°C	Dual Pro Wash 60°C	Quick 30' 40°C (press 2 times for Self Clean)	Mini 14'	
S3X	60cm	BLDC	Yes	8	Eco	Smart 60°C - 70°C	Hygiene 70°C	Save+ 5.4 lt	Super 50' 65°C	Dual Pro Wash 60°C	Quick 30' 40°C (press 2 times for Self Clean)	Mini 14'	
SA5	60cm	Async.	No	6	Regular	Auto	Intensive	Delicate	Super 50' 65°C	Rinse			
SA7	60cm	Async.	No	8	Regular	Auto	Intensive Plus	Intensive	Daily	Delciate	Super	Rinse	
SB5	60cm	Async.	Yes	6	Regular	Auto	Intensive	Delicate	Super 50' 65°C	Rinse			

SB7	60cm	Async.	Yes	8	Regular	Auto	Intensive Plus	Intensive	Daily	Delciate	Super	Rinse	
SB5_BLDC	60cm	BLDC	Yes	6	Regular	Auto	Intensive	Delicate	Super 50' 65°C	Rinse			
SB7_BLDC	60cm	BLDC	Yes	8	Regular	Auto	Intensive Plus	Intensive	Daily	Delciate	Super	Rinse	

S series 60 cm option table

S series 60cm	Delay timer option		Half load		Extra Hygiene (Sanitize)	Tablet (Hi-Temp)	Extra Rinse	Extra Drying	Extra Silent	Extra Fast	Energy Save
	Model	3,6,9hr	1-2-...-24hr	1 mode							
S12	Yes	-	Yes	-	-	Yes	-	(o)	-	-	(o)
S13	Yes	-	Yes	-	-	Yes	-	(o)	-	-	(o)
S14	Yes	-	Yes	-	-	Yes	-	(o)	-	-	(o)
S15	Yes	-	Yes	-	-	Yes	-	(o)	-	-	(o)
S16	Yes	-	Yes	-	-	Yes	-	(o)	-	-	(o)
S23	-	Yes	Yes	-	Yes	Yes	- (Yes with wifi)	(o)	-	-	(o)
S24	-	Yes	Yes	-	Yes	Yes	- (Yes with wifi)	(o)	-	-	(o)
S25	-	Yes	Yes	-	Yes	Yes	- (Yes with wifi)	(o)	-	-	(o)

S26	-	Yes	Yes	-	Yes	Yes	- (Yes with wifi)	(o)	-	-	(o)
S27	-	Yes	Yes	-	Yes	Yes	- (Yes with wifi)	(o)	-	-	(o)
S28	-	Yes	Yes	-	Yes	Yes	- (Yes with wifi)	(o)	-	-	(o)
S29	-	Yes	Yes	-	Yes	Yes	- (Yes with wifi)	(o)	-	-	(o)
S31	-	Yes	-	Yes	Yes	Yes	Yes	(o)	-	-	(o)
S32	-	Yes	-	Yes	Yes	Yes	Yes	(o)	-	-	(o)
S33	-	Yes	-	Yes	Yes	Yes	Yes	(o)	-	-	(o)
S34	-	Yes	-	Yes	-	Yes	-	(o)	Yes	Yes	(o)
S36	-	Yes	-	Yes	-	Yes	- (Yes with wifi)	(o)	Yes	Yes	(o)
S37	-	Yes	-	Yes	-	Yes	- (Yes with wifi)	(o)	Yes	Yes	(o)
S38	-	Yes	-	Yes	-	Yes	- (Yes with wifi)	(o)	Yes	Yes	(o)
S39	-	Yes	-	Yes	-	Yes	- (Yes with wifi)	-	Yes	Yes	Yes
S3X	-	Yes	-	Yes	-	Yes	-	Yes	Yes	Yes	(o)
SA5	-	Yes	Yes	-	Yes	Yes	-	Yes	-	-	-
SA7	-	Yes	Yes	-	Yes	Yes	-	Yes	-	-	-
SB5	-	Yes	-	Yes	Yes	Yes	Yes	Yes	-	-	-
SB7	-	Yes	-	Yes	Yes	Yes	Yes	Yes	-	-	-
SB5_BLDC	-	Yes	-	Yes	Yes	Yes	-	Yes	Yes	Yes	-
SB7_BLDC	-	Yes	-	Yes	Yes	Yes	-	Yes	Yes	Yes	-

S series 45 cm program table

S series 45cm	Size	Motor Type	Electrical Diverter	Total Program #	P1	P2	P3	P4	P5	P6	P7
Model											
S12	45cm	Async.	-	2	Eco	Intensive 65°C or Smart 60°C - 70°C					
S13	45cm	Async.	-	3	Eco	Intensive 65°C or Smart 60°C - 70°C	Super 50' 65°C				
S14	45cm	Async.	-	4	Eco	Intensive 65°C or Smart 60°C - 70°C	Super 50' 65°C	Mini 14'			
S15	45cm	Async.	-	5	Eco	Intensive 65°C or Smart 60°C - 70°C	Super 50' 65°C	Quick 30' 40°C	Mini 14'		
S16	45cm	Async.	-	6	Eco	Intensive 65°C or Smart 60°C - 70°C	Hygiene 70°C	Super 50' 65°C	Quick 30' 40°C	Mini 14'	
S23	45cm	Async.	-	3	Eco	Intensive 65°C or Smart 60°C - 70°C	Self Clean				
S24	45cm	Async.	-	4	Eco	Intensive 65°C or Smart 60°C - 70°C	Super 50' 65°C	Self Clean			
S25	45cm	Async.	-	5	Eco	Intensive 65°C or Smart 60°C - 70°C	Super 50' 65°C	Mini 14'	Self Clean		
S26	45cm	Async.	-	6	Eco	Intensive 65°C or Smart 60°C - 70°C	Super 50' 65°C	Quick 30' 40°C	Mini 14'	Self Clean	
S27	45cm	Async.	-	7	Eco	Intensive 65°C or Smart 60°C - 70°C	Hygiene 70°C	Super 50' 65°C	Quick 30' 40°C	Mini 14'	Self Clean
S31	45cm	Async.	Yes	5*	Eco	Intensive 65°C or Smart 60°C - 70°C	Super 50' 65°C (press 2 times for Self Clean)	Quick 30' 40°C			
S32	45cm	Async.	Yes	6*	Eco	Intensive 65°C or Smart 60°C - 70°C	Super 50' 65°C	Delicate 40°C (press 2 times for	Quick 30' 40°C		

								Self Clean)			
S33	45cm	Async.	Yes	7*	Eco	Smart 60°C - 70°C	Steam Wash	Super 50' 65°C	Delicate 40°C (press 2 times for Self Clean)	Quick 30' 40°C	
S34	45cm	BLDC	Yes	7*	Eco	Smart 60°C - 70°C	Steam Wash	Super 50' 65°C	Dual Pro Wash 60°C (press 2 times for Self Clean)	Quick 30' 40°C	

S series 45 cm option table

S series 45cm	Delay timer option		Half load		Extra Hygiene	Extra Rinse	Extra Drying	Extra Silent	Extra Fast	Energy Save
	3,6,9hr	1-2-...-24hr	1 mode	3 modes						
S12	Yes	-	-	-	-	-	-	-	-	-
S13	Yes	-	-	-	-	-	-	-	-	-
S14	Yes	-	-	-	-	-	-	-	-	-
S15	Yes	-	-	-	-	-	-	-	-	-
S16	Yes	-	-	-	-	-	-	-	-	-
S23	-	Yes	Yes	-	-	-	(o)	-	-	(o)
S24	-	Yes	Yes	-	-	-	(o)	-	-	(o)
S25	-	Yes	Yes	-	-	-	(o)	-	-	(o)

S26	-	Yes	Yes	-	-	-	(o)	-	-	(o)
S27	-	Yes	Yes	-	-	-	(o)	-	-	(o)
S31	-	Yes	-	Yes	Yes	Yes	(o)	-	-	(o)
S32	-	Yes	-	Yes	Yes	Yes	(o)	-	-	(o)
S33	-	Yes	-	Yes	Yes	Yes	(o)	-	-	(o)
S34	-	Yes	-	Yes	-	-	-	Yes	Yes	Yes

DISPLAY VIEWS

Middle Display



Front display



While the half load selected program is running, the lower half load icon lights up on the front display in models without a divider.

60-45 cm S2 Series

wifi*	Self clean	salt	rinse aid	8:88	delay			
Tablet		CL	End					

60 cm S3 Series

wifi*	Self clean	salt	rinse aid	8:88	delay			HL Up
Tablet		CL	End					HL Low

60 cm Uvli S36-S37-S38-S39

wifi*	Self clean	salt	rinse aid	8:88	delay			HL Up
Tablet		CL	End		UV			HL Low

45 cm S31-S32-S33

wifi*	Self clean	salt	rinse aid	8:88	delay			HL Up
Tablet		CL	End					HL Low

45 cm S34

wifi*	Self clean	salt	rinse aid	8:88	delay	Fast		HL Up
Tablet		CL	End				Silent	

45 cm Uvli S34

wifi*	Self clean	salt	rinse aid	8:88	delay	Fast		HL Up
Tablet		CL	End		UV	Silent		HL Low

60 cm SA5-SA7

		salt	rinse aid	8:88	delay			
	Sanitized		End					

60 cm SB5-SB7

		salt	rinse aid	8:88	delay			HL Up
	Sanitized		End					

60 cm SB5_B-SB7_B

		salt	rinse aid	8:88	delay			HL Up
	Sanitized		End					

45 cm SA5-SA7

		salt	rinse aid	8:88	delay			
	Sanitized		End					

45 cm SB5

		salt	rinse aid	8:88	delay			HL Up
	Sanitized		End					

45 cm SB5_B

		salt	rinse aidsalt	8:88	delay	Fast	Dry	HL Up
	Sanitized		End				Silent	Sanitize

- Self Clean, an extra machine cleaning program that is active when the 2nd program from the right is pressed twice, selected with the program navigation arrows in S2
- Tablet is activated from the menu. Once activated, it will always be active.
- When the program is finished without any interruption and reaching the relevant temperature, the Sanitized icon lights up. (in USA)
- Child lock is activated when the buttons specified on the panels are pressed together for 3 seconds, the CL icon lights up on the display. At this time, it counts backwards from 3 on the display. (When activating; 3-2-1-CL1) (When deactivating; 3-2-1-CL0)

LED behavior

- When half load is selected (any of the 3 modes) in models with a divisor, the led on the button will also light up.
- In models without a divider, only the led on the button lights when half load is selected.
- When one of Fast/Silent is selected in S3 BLDC 45cm, the led on the button does not light, only the icons on the middle display light up. In America S3 BLDC 45 cm, when one of Dry/Sanitize is selected, the led on the button does not light up, only the icons in the middle display light up.
- When Delay is selected, the LED on the button does not light.
- When the on/off button is pressed, the led on the button does not light up.
- When the program buttons are pressed in S2, the led on the button does not light up.

COMPATIBILITY BETWEEN OPTIONS & PROGRAMS IN EUROPE MODELS

S series		Options							
		Energy Save	Extra Fast	Half Load	Triple & Direct	Extra Silent	Ext Dry	Ext Hygiene	Ext Rinse
Programs	Eco	OK	OK	OK	OK	OK	OK	OK	OK
	Smart Programs	OK		OK	OK		OK	OK	OK
	Intensive / Auto	OK		OK	OK		OK	OK	OK
	Hygiene	OK		OK	OK		OK		OK
	Steam Wash			OK	OK		OK	OK	OK
	Save+ 5.4 lt	OK	OK	OK	OK	OK	OK	OK	OK

	Dual Prowash	OK	OK	OK	OK	OK	OK	OK	OK
	Delicate	OK		OK	OK		OK	OK	OK
	Easy Care	OK		OK	OK		OK	OK	OK
	Super	OK		OK	OK		OK	OK	OK
	Quick	OK		OK	OK		OK	OK	OK
	Mini 14'	OK		OK					
	Prewash			OK	OK				

S USA models	Program-Option Compatibility								
	delay	Child Lock	Half Load	Sanitize	H.Temp	Ext Dry	Extra Fast	Extra Rinse	Extra Silent
Regular	X	X	X	X	X	X	X	X	X
Auto	X	X	X	X	X	X	X	X	X
Intensive +	X	X	X	X	X	X	X	X	X
Intensive	X	X	X	X	X	X	X	X	X
Daily	X	X	X	X	X	X	X	X	X
Delicate	X	X	X	-	-	X	X	X	X
Super	X	X	X	X	X	X	-	X	-
Rinse	X	X	X	-	-	-	-	-	-

COMPATIBILITY BETWEEN OPTIONS IN EUROPE MODELS

Options	Energy Save	Extra Fast	Half Load	Triple & Direct	Extra Silent	Extra Dry	Ext Hygiene	Extra Rinse
Energy Save		OK	OK	OK	OK	OK	OK	OK
Extra Fast	OK		OK	OK		OK		
Half Load	OK	OK			OK	OK	OK	OK
Triple & Direct	OK	OK			OK	OK	OK	OK
Extra Silent	OK		OK	OK		OK		
Extra Dry	OK	OK	OK	OK	OK			OK

Ext Hygiene	OK		OK	OK				OK
Extra Rinse	OK		OK	OK		OK	OK	

COMPATIBILITY BETWEEN OPTIONS IN USA MODELS

Options	Extra Fast	Half Load	Extra Dry	Sanitize	Hi-Temp	Extra Rinse	Extra Silent
Extra Fast		OK	OK	-	OK	OK	-
Half Load	OK		OK	OK	OK	OK	OK
Extra Dry	OK	OK		-	OK	OK	OK
Sanitize	-	OK	-		OK	OK	-
Hi-Temp	OK	OK	OK	OK		OK	OK
Extra Rinse	OK	OK	OK	OK	OK		-
Extra Silent	-	OK	OK	-	OK	-	

Compatibility of Triple&Direct Option and Programs

	If the option can be selected			
	Without option	Autodoor	Half Load	Other all options
Prewash	-	NA	+	NA
Mini 14' (Jet Wash)	-	-	-	-
Eco (Standard Programme)	-	-	+	+
Save+ 5.4 lt	-	-	+	+
Quick 30' 40°C	+	+	+	+
Super 50' 65°C (Quick Clean)	+	+	+	+
Delicate 40°C	+	+	+	+
Clean+ 55°C	+	+	+	+
Easy Care 60°C	+	+	+	+
Dual Pro Wash 60°C	+	+	+	+
Intensive 65°C	+	+	+	+
Hygiene 70°C	+	+	+	+
Auto**	+	+	+	+
Smart 30°C - 50°C	+	+	+	+
Smart 50°C - 60°C	+	+	+	+
Smart 60°C - 70°C	+	+	+	+
Steam Wash	+	NA	+	+

OPTION DEFINITION

Option	Short description
Delay Timer	Program starts with a delay
Half Load(3 modes)	The wash is executed with upper spray,
	lower spray or both in half load mode.
Energy Save	At the end of the drying process, the dishwasher door automatically opens to allow steam to escape and cool air to circulate. (Sadece programa ilk start verilmeden seçilebilir.)
Extra Fast	Reduces the duration of the washing. (Sadece programa ilk start verilmeden seçilebilir.)
Extra Silent	Reduces the sound pressure level of the washing. (Sadece programa ilk start verilmeden seçilebilir.)
Extra Hygiene	Increase the washing temperature at final rinse step in order to eliminate bacteria
Extra Dry	This option increases water temperature at final rinse step and increase drying step duration up to 10 min.
Extra Rinse	Extra rinse option adds an extra rinse step to achieve more hygienic washing. Programme duration is increased between min. %4 and max. %16 according to washing programme

Delay Timer

The delay timer option is selected by pressing the regarding option button before the program starts. It is possible to select the delay before selecting the program.

Before program is started, all indicator leds and delay leds are OFF.

Before starting the program,

Delay is selected by consecutive pressures of the button. The required delay value is chosen

At each pressure, the display shows one step of increment (from 1h to 24h); having been reaching its maximum value (24h)

The next pressure clears the delay and shows "0h".

Before closing the door, selected program and delay durations are shown on the display alternately in 2" interval.

After closing the door, the program with delay will be in operation.

Cancelling the delay start is possible during the delay time.

- Open the door
- Press the delay button, until the delay time is "0h"
- Press Start/Start button and the washing program will start.

In the middle of the delay time, when adding or subtracting ops without changing the delay time, the delay

time continues from where it left off. However, if the delay time changes, the newly selected delay time starts over. If any program button is pressed before the delay is selected and started or after it has been started and stopped, the delay will be canceled and the machine will go to the ready state in the selected program.

When delay timer is selected, if machine switch off and on by ON/OFF button, delay timer is cancelled and machine goes to ready state.

If mains power off-on occurs (power cut); delay time resumes, does not start again.

When delay timer is selected but not started or started and paused, if any program button is pressed, delay timer is cancelled and machine goes to ready state.

Half Load

The wash is executed with upper spray, Lower spray or both in half load mode.

Half Load option is selected at any time (during program or before starting program) by pressing the regarding option button.

First Press: Upper spray led is ON and lower spray led is OFF. Wash is executed only with upper spray arm.

Second Press: upper spray led is OFF and lower spray led is ON. Wash is executed only with lower spray arm.

Third Press: Upper spray led is ON and lower spray led is ON à Half Load washing.

Fourth Press: Upper spray led is OFF and lower spray led is OFF a Normal washing.

Sanitized Feature(for USA models)

When compatible programs (except Super from 6 compatible programs) are run with the Sanitize option; If 66 degrees Celsius is reached in the hot rinsing phase and the program ends without interruption, the «Sanitized» icon lights up continuously at the end of the program.

The Sanitized icon does not light up at the end of the program when it cannot reach 66 degrees in the hot rinsing phase or the program is interrupted. Intention without interruption; There may be machine off on, pause-start, door open-close or error conditions.

Although the Super program is compatible with sanitize and provides what is required in the program, the sanitized led does not turn on at the end.

If we do not close the door within 4 seconds after pressing the start button to start the program when the door of the machine is open, if we press the start button again and close the door within 4 seconds and start the program, it will be perceived as uninterrupted.

If the program with the sanitize option is selected and finished successfully, both the finished and sanitized leds turn on at the end of the program.

	Sanitize	Sanitized
Regular	X	X
Auto	X	X
Intensive +	X	X
Intensive	X	X
Daily	X	X
Delicate	-	-
Super	X	-
Rinse	-	-

MENU SETTINGS

Entering the menu; Pressing the **Menu** button (4th button from the left without counting the on/off button) for 3 seconds (on the display 3 2 1, then the first setting, SL3, etc.) (the icon of the relevant setting lights up on the middle display, the other icons turn off, while in the setting without an icon) no icon lights in the middle display like buzzer)

Navigating the menu; The program is made with the lower / upper (S2) or Delay (S3) keys (without counting the On/off button, always the 1st and 2nd button from the left) (At the same time, SL3, r:4, .. lights up on the display continuously),
Going down to the level of the setting to be changed in the menu; It is done with the Select button (Always the 3rd button from the left without counting the On/off button) (Selected setting, for example, blinks on the SL3 display)

Changing levels in the menu; The program is done with the lower/upper(S2) or Delay(S3) keys (always the 1st and 2nd buttons from the left without counting the On/off button). (changed levels keep blinking like SL3, SL4),

When the desired level is reached, the level is saved by pressing the Select button, it starts to light up continuously like S:4 blinking on the display and goes to the menu (upper level) (if the menu is exited without pressing the selecte, it does not save the level).

Exit from the menu; It is done by pressing the Menu button for 3 seconds (shown as 3 2 1 on the display) and when the menu is exited, the last changed levels are saved.

When the machine is turned on again, it opens at the last saved level.

If the machine is turned on/off while in the menu, the opening program is displayed when it is turned on. (does not continue from the menu).

For S29



For S 39



MENU SETTINGS

ORDER	FEATURE	WILL BE SHOWN ON DISPLAY	EXPLANATION	NOTE
1	Salt			
		SL1		
		SL2		
		SL3	default	
		SL4		
		SL5		
		SL6		
2	Polisher			
		r:1		
		r:2		
		r:3		
		r:4	default	
		r:5		
3	buzzer			
		b:0		
		b:1		
		b:2		
		b:3	default	
4	Boot program selection			
		LP0	Default -> Eco + okam opens	
		LP1	It opens with the last selected program and option.	
5	Tablet (not available in the US)			
		A:0	Tablet option off (Default)	
		A:1	Tablet option turned on	
6	Save Power Mode			
		SP0		interior lighting off; screen 4, the machine turns off after 15 minutes.
		SP1	default	Interior lighting and display turn off after 4 minutes and after 15 minutes.
		SP2		When the door is opened while the machine is off, the interior lighting is on for 4 minutes. When the machine is on, the machine is always on; As long as the door stays open, the interior lighting is also on.

7	Wifi on-off	0	wifi off	If the wifi is turned off after the installation, the wifi leds turn off, but the wifi connection continues in the background, the config is not reset.
		1	wifi on (Default)	After the installation is done, when the wifi is turned on again from the wifi off, the wifi leds turn on as the wifi connection is made and the remote can be turned on/off.
8	Factory Reset	FS0	default	
		FS1		Returns to factory setting.

HIDDEN MENU SETTINGS

To enter the hidden menu; As soon as the machine is turned on, the Menu (4th button from the left without counting the On/off button) is pressed for 5 seconds.

Navigating in the hidden menu; Program up/down(S2) or Delay(S3) (without counting the On/off button, always the 1st and 2nd button from the left) keys,
In order to activate the modes in the menu, the door is closed without pressing the Start/Pause button after coming to the relevant mode.

ENTERING THE HIDDEN MENU FOR S29



ENTERING THE HIDDEN MENU FOR S39



Note: BLDC motor test (if available in the model) is opened when the hidden menu settings combination is entered while the program is running, and the test starts when the door is closed.

FEATURE	WILL BE SHOWED ON DISPLAY	EXPLANATION	NOTE
1	Service Test	SP	
2	Auto Door Test	dCO	
3	BLDC Motor Test	Pc	Pco is written when the BLDC motor is tested and started.
4	Water Save Control Test	rc	

WIFI SETTINGS AND CONTROLS

Config buttons

For config, press and hold Remote button for 5 seconds. For with display models; during 5 seconds display counts down from 5 to 1 and then shows CF. (5-4-3-2-1-CF)

Remote Control buttons

For remote, press Remote button momentarily.

Device panel selection images on the app:

S1 Control System



S2 Control System



S3 Control System



Wifi Specifications



- For the automatic ping test in production; at the first energizing, machine broadcasts wifi for 10 minutes. During ET2 wifi modul energy is cut, wifi does not broadcasting on ET2 mode. When it switches to ET3, it continues to count the 10 minutes from where it left off.
- When the machine is in End test 3, if any button is pressed, machine goes to the ready state.
- The machine broadcasts for 10 minutes after config buttons are pressed and CF is seen on the screen. After config buttons are pressed, only wifi led blinks during broadcasting.
- If the wifi setup is not completed after pressing the config buttons once on the machine and CF is seen on the screen, the wifi leds are off when the machine is turned off and on.
- If wifi is configured on the machine, the wifi led lights up continuously. When the remote is activated, the remote led lights continuously.
- If the modem connection is established within 30 seconds after the machine is turned off and on after the installation, the wifi led lights up as soon as the connection is established. If the time to connect to the modem is longer than 30 seconds, after 30 seconds, the wifi and remote leds will blink until the modem connection is

established. When the machine is reconnected to the modem, the wifi led lights up continuously, the remote led does not light up.

- If the modem is disconnected while wifi is configured, the wifi and remote leds will blink until it is reconnect.
- If the remote is deactivated after configuration, the machine turns off after 15 minutes. If the remote is active, the machine does not turn off after 15 minutes, the screen is turned off and only the wifi and remote leds turn on. The machine wakes up when intervention is made on the machine or from the application.
- After configuration, remote control may appear as active. (It depends on which statues left of the same wifi board on the previous connection)

	After End Test 3, in all turning on without pressing the config buttons	After pressing the config buttons	In off-on status after pressing Config buttons	After connection (without activating Remote)	After the remote is activated	If machine is turned off and on after connection (with or without Remote activation)	
						If modem is connected within 30 seconds after machine is turned on.	If modem is not connected within 30 seconds after machine is turned on.
Wifi Led	No	Yes, as blink for 10 min.	No	Yes, continuously	Yes, continuously	Yes, continuously after connection	After 30 seconds, it will blink until modem is connected. When modem is connected, the wifi led turns on continuously.
Remote Led	No	No	No	No	Yes, continuously	No	After 30 seconds, it will blink until modem is connected.
Wifi broadcast	Yes, for 10 min.	Yes, for 10 min.	Yes, for 10 min.	No	No	No	No

Led Behaviours

LED BEHAVIOURS			
Mode	 Wifi Led	 Remote Control Led	Note
Not configed for the first time	OFF	OFF	Before CONFIG button combination is pressed at the first time

Wifi configuration step	BLINK	OFF	After CONFIG button combination is pressed, WIFI of machine is active, ready for connection to modem. Shows that user is in the connection step. 5 minutes after Config button combination pressed, if product does not connected to any modem, Wifi led turns OFF, and Not Configged mode is ON.
RC (remote control)active	ON	ON	product connected to modem, remote control active
RC inactive (Config completed)	ON	OFF	product connected to modem, remote control inactive
Internet lost when connected	BLINK	BLINK	After the connection is set up and RC is ON; this behaviour happens; 1)if the internet of the dishwasher is lost (If internet comes again, RC ACTIVE mode will be ON) or, 2)if the power of the machine is ON again after a power loss (If the connection is succeeded, RC INACTIVE mode is ON)

Security related Wifi controls;

1) If config operation is done, when the program is started, RC is automatically activated (no need to activate the RC by pressing the button on control panel)
(not valid if the program is started when the door is open)

2) RC becomes OFF;

- when the door is opened
- when the machine is turned off and on
- if the energy of the machine is lost because of the loss of line

3) When the door is open;

- RC cannot be activated

WIFI SLEEP mode:

While RC is ON;

- Machine does not turn off automatically (even in ECO MODE). The screen goes to WIFI SLEEP mode 15 minutes after the ready state or 15 minutes after the program finished.

During wifi sleep mode;

- If there is internet; only WIFI+ RC icons/leds are ON, all other leds are OFF.
- If the internet connection of the machine is lost in this mode, WIFI SLEEP mode continues, only WIFI+RC icons blink until the internet is connected again.

The Mind of the House Mobile Application;

- 1) When Config is ON and RC is OFF, machine can be remotely monitored, which means machine can not be controlled from the application, but status of the machine can be monitored on the application.
- 2) When ionizer is activated on the machine, it can be seen on the application with a notification. The ionizer function can be canceled on mobile application.

Phase-2 Features (21.06.2021)

1. Remote Control key display

In addition to the warning that remote control must be activated in order to remotely control the machine while in remote monitoring mode, it is shown which button to activate the remote control on the panel. Depending on the model, the panel visual and remote control buttons vary.

2. Save favorite program

Favorite program is saved by pressing and holding the favorite icon for 3 seconds on the application. Favorite is selected with a single press.

3. Salt/Rinse aid Out Alert; It is also given via the app simultaneously with the machine.

These warnings are not always presented to the user, but the user is informed with an option such as "Notifications" or "Warnings".

4. Displaying the selected options while the program is running

When the additional features are selected, the additional feature information selected in addition to the program is displayed on the application screen while the program is running.

5. Information on which stage the program is in is displayed.

6. Machine error notifications are sent to the phone even when the application is closed.

7. Incorrect Wi-Fi password of the modem:

If the modem's password is entered incorrectly, the password error is displayed on the same application interface.

8. Remove the extra mac id selection step on iOS devices

In android, this step is skipped when only one SSID is found. Similarly, when there is only one SSID, the relevant step should be skipped in the IOS application.

9. Family account

Users can use the machine from different phones with the same account at the same time.

10. Activation – deactivation of Active Ion Technology (Ion) and Daylight Technology (UV)

Active Ion Technology (Ion) and Daylight Technology (UV) can also be activated or deactivated via the application.

11. Opening program+option setting

The following selections are presented with an option such as "Startup Program" from the application settings.

1- Last selected (when this is selected, it should open as program + additional feature)

2- Eco

3- Super 50'

4- ... (other programs)

12. Child lock setting, informing when active

Child lock can be activated / deactivated from the application and when activated, a warning is displayed in the application.

13. Buzzer volume setting

Buzzer volume can be adjusted from the application.

14. Activating-deactivating the Energy Saving mode, information note

Energy saving (save power mode) mode can be activated / deactivated from the application and information is given.

15. Program and delay times are set as <start + duration = end> time display.

16. Water hardness / rinse aid can also be adjusted through the application.

17. Program / option information notes are displayed to the user through the application.

18. The User Manual link can be accessed through the application.

19. Demo Mode demonstration

A demo mode is displayed where the application features can be observed even if the machine is not installed.

20. Turn off/on the machine from the application

The machine can be turned ON-OFF with a button via the application. Thus, closing over the machine differs from closing over the application. When it is closed from the application, only the screen is turned off by switching to wifi sleep mode. In this mode, if the door is opened while the machine is off, the remote will break and a warning will be given via the application. As long as the door remains closed, the machine that is closed from the application can be opened again without the application.

21. Smart Consumption setting

Information about the times when electricity consumption is cheap (at night) is given via the application, and the automatic delay option is offered to the user, so that the machine will operate in saving hours while the smart consumption setting is active.

Salt-Rinse-Regeneration

WATER HARDNESS SET

Default water hardness level set is SL3 for Europe. For USA models, default water hardness level set is SL1.

1. Open the door of the machine,
2. Switch on the machine and activate the menu. Then find the salt setting as SL1~SL6.
3. The last setted level will be shown on the display.

		For 60 cm	For 45 cm
Water Hardness level	Display	Litres	Litres
Level 1	SL1	Never	Never
Level 2	SL2	116 lt	100 lt
Level 3	SL3	64 lt	72 lt
Level 4	SL4	52 lt	41 lt
Level 5	SL5	46 lt	28 lt
Level 6	SL6	16 lt	14 lt

Note: For S1 models (withOUT display); when Salt level is changed, leds shown below table will be on.

Salt level	P1	P2	1/2	3h	6h	9h
L1	X					X
L2		X				X
L3			X			X
L4				X		X
L5					X	X
L6	X				X	X

RINSE AID SET

If it is the first rinse aid set, default rinse aid level is r4 which corresponds to 4,5 cc.

1. Open the door of the machine,
2. Switch on the machine and activate the menu. Then find the rinse aid setting as r:1~r:5.
3. The last setted level will be shown on the display.

Rinse aid level	P1	P2	1/2	3h	6h	9h
r1 (0 cc)	X					X
r2 (1.5 cc)		X				X
r3 (3 cc)			X			X
r4 (4.5 cc)				X		X
r5 (6 cc)					X	X

If the rinse aid tank is empty and user sets rinse aid level as 1(0cc), "lack of rinse aid" warning is not shown.

Sliding dispenser dosages are shown below in detail.

1 rinse aid dosage is performed when dispenser is ON during 8" and OFF during 8" . =>1,5cc

2 rinse aid dosages are performed 8" ON-8" OFF-8" ON-8" OFF=>3cc

3 rinse aid dosages are performed 8" ON-8" OFF-8" ON-8" OFF-8" ON-8" OFF=>4,5cc

4 rinse aid dosages are performed 8" ON-8" OFF-8" ON-8" OFF-8" ON-8" OFF-8" ON-8" OFF =>6cc

<i>Action</i>		<i>New(Sliding dispenser)</i>	
Detergent cover opening:		0.3"	
Rinse aid dose:	Dose setting:	Automatic in the software	
	Dose quantity and time to delivery	1 - 0cc	OFF
		2 - 1.5cc	8"ON; 8"OFF
		3 - 3cc	8"ON; 8"OFF
		4 - 4.5cc	8"ON; 8"OFF
		5 - 6cc	8"ON; OFF
	n/a	n/a	
Standard dose of rinse aid setting by manufacturer	(4-4,5cc set by software)		

REGENERATION CYCLE

When it occurs the regeneration valve works after last rinse and during the drying steps. There are 6 hardness levels.

	For 60 cm	For 45 cm
Water Hardness level	Litres	Litres
Level 1	Never	Never
Level 2	116 lt	100 lt
Level 3	64 lt	72 lt
Level 4	52 lt	41 lt
Level 5	46 lt	28 lt
Level 6	16 lt	14 lt

The consumed liters are counted by flow meter impulses.

In case of flow meter broken, the liters corresponding at the flow meter time out are used

If user cancels a program during regeneration or after regeneration and before resin wash, at the beginning of the next program the dishwasher performs the resin wash to remove the salty water from the resin chamber. The resin wash will be: load 2 lt of water with drain pump on. During the resin wash the circulation Pump must be off.

Regeneration is not performed at prewash program

If tablet option is selected and water hardness level is 1, 2, 3 or 4; regeneration is not performed. In the next program, if tablet is not selected anymore, regeneration performs at the end of the program.

If water hardness level is changed from lower to higher, regeneration cycle is performed at the end of the first program

If water hardness level is changed from higher to lower, regeneration cycle is not performed at the end of the first program. Regeneration is performed after water level reach to value of level

"For 60 cm models:

- If Water hardness level is 5 or 6
 - First regeneration step is performed 0,2lt water
- If Water hardness level is 2 or 3 or 4
 - First regeneration step is performed 0,1lt water
- If Water hardness level is 1
 - Regeneration step is not performed

Second regeneration step is performed 0,2 lt water except level 1

For 45 cm models:

First and second regeneration steps are performed 0,2 lt water except level 1

"

The consumed liters are counted by FLM(flow meter) impulses.

In case of FLM broken, the liters corresponding at the FLM time out are used. (2,1 lt + 2,5 lt).

In case of "Tablet" option is ON;

If the level set is less than L4: the regeneration cycle is not performed, but the quantity of consumed water is counted. When the target value is reached, at the first cycle without the "Tablet" ,the regeneration cycle is performed.

If the level set is equal or more than L5: the regeneration cycle is performed when the quantity target is reached.

If the washing program is a "prewash program", the regeneration cycle is not performed.

If user cancels a program during regeneration or after regeneration and before resin wash, at the beginning of the next program the dishwasher performs the resin wash to remove the salty water from the resin chamber. The resin wash will be: load 2 lt of water with drain pump on.

During the resin wash, the circulation Pump must be OFF.

If the level of regeneration step is incremented, (for ex: from level3 to level 6) ,at the end of the next washing cycle, it must perform resin wash.

If the regeneration level is decremented, (for ex: from level4 to level 3); checked how much water used until then and according to new level, how much water will be used more for resin wash is calculated.(level 3=64 lt- used liters until then).

During waiting step of regeneration process, end user open/close the door or Power OFF/ON condition, program goes to END, but next step of washing cycle starts with resin wash, so that water level resets to zero and re-counts down from corresponding water level.

When there is no flowmeter connection (by removing flowmeter cable), Electronic card saves the water as 4,58 lt per step.

If there occurs regeneration step after the programs without drying step or programs having less than 15min drying step, at the end of the program (before reg cycle) the duration must be corrected from 0:01 to 0:15 and recount down during reg step.

VOLTAGE SENSE-NTC VALUES

Voltage Sensing Control

When main supply voltage is below 145VAC, voltage sensing circuit detect low voltage and program is stopped by software.

Take memory failure code of low voltage to show at the beginning of service test.

After main supply voltage is above 155VAC, program is started again

When main supply voltage is above 285VAC, voltage sensing circuit detect high voltage and program is stopped by software.

Take memory failure code of high voltage to show at the beginning of service test.

After main supply voltage is below 275VAC, program is started again

If voltage is low or high during 3 hours or more, at the end of the 3 hours:

Program go to failure routine without draining, Failure code of low voltage is shown to user

Program go to failure routine without draining , Failure code of high voltage is shown to user

For 110V models: Low voltage detection is not available, only high voltage is detected as following:

When main supply voltage is above 145VAC, voltage sensing circuit detect high voltage and program is stopped by software.

Take memory failure code of high voltage to show at the beginning of service test.

After main supply voltage is below 135VAC, program is started again

If voltage is high during 3 hours or more, at the end of the 3 hours:

Program go to failure routine without draining , Failure code of high voltage is shown to user

FEATURE OF TIME PHASE

- At the beginning of the main wash of eco program, If temperature of water < 30C , Time phase is not activated at the main wash of eco program
- At the beginning of the main wash of eco program, If temperature of water > 30C , Time phase is

activated at the main wash of eco program

- These two rules cover only eco programs.

NTC VALUES

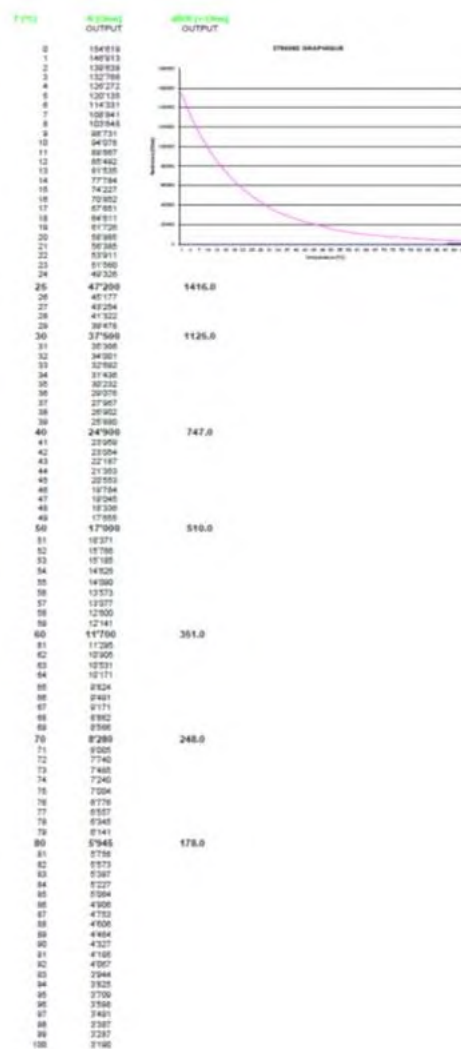

STARTING THE PROGRAM

For USA models 4 seconds rule: To start the selected program or delay timer, press Start/Pause button and close the door within 4 seconds. If the door is not closed within 4 seconds after Start/Pause button pressed, program / delay timer will be paused. **During this 4 seconds, display counts down from 4 to 1.**

For Europe models: To start the selected program or delay timer, pressing Start/Pause button is enough. There is no 4 seconds rule.

OPERATION OF FUNCTIONAL FEATURES

Child Lock

S29 Press 2 buttons at the same time for 3 seconds to activate child lock.



Ionizer

Ionizer function is activated/deactivated by pressing "Ion" button momentarily (For S3 Asy 60 cm models) (in this condition ion button led lights up), by pressing "UV" button for 3" (For S3 BLDC 60 cm models) and by pressing "Fast/Silent" button for 3"(For S3 BLDC 45 cm models). Display shows 3-2-1 then, at the end of 3" display shows "Ion" to indicate that ionizer is activated. In deactivation, display shows 3-2-1 then at the end of 3" ionizer function is cancelled.

When the door is closed and the function is selected, ionizer function will start.

Ionizer cycle is as follow: 5' ON, 55' OFF, 5' ON,55' OFF,.. After 24 hours is completed, ionizer function is deactivated automatically by software. During 5' ON; ionizer component and mini fan work together. During 55", they do not work.

If there is no intervention, it continues until 24 hours is completed. After 24 hours, it is automatically deactivated. When ionizer deactivated, machine goes to standby position.

Ionizer does not work together with any program or not executed in any program.

When the door is opened during ionizer is active, ionizer led and inner light will turn on, ion led lights up like dimming. Also, "Ion" blinks on the display. Ionizer function pauses if the door is open. To continue, the door must be closed.

When machine is turned off and then on, ionizer function is cancelled.

Uvon

Uvon function are optional for only BLDC models. Asynchronous models do not have this function.

UVON function is activated/deactivated by pressing "UV" button momentarily for BLDC 60 cm models(in this condition UV button led and UV icon lights up). UVON function is activated/deactivated by pressing "Extra Hygiene" button for 3" for BLDC 45 cm models. Display shows 3-2-1 then, at the end of 3" display shows "U1" to indicate that UV is activated and UV icon lights up on the display. In deactivation, display shows 3-2-1 then, at the end of 3" display shows "U0" to indicate that UV is deactivated and UV icon led turns off on the display.

UVON led is driven from the same output with ionizer fan. UVON is active only in program having drying phase. If UVON is activated and washing program is started, UV led turns on during the first 10 minutes of drying phase.

Also, if regeneration occurs and UVON is active, UV led will be on during the first 10' of regeneration.

Default set is deactivated form.

At the end of program, if user don't deactivate it, UVON remains active until machine is turned off and on. When machine is turned off and then on, UVON is deactivated.

If UVON is active, ion led lights up like dimming during door is open.

UV led is never ON when the door is open. Status of leds are given below:

State&UVON	UVON is OFF		Standby & UVON is ON		Program is washing & UVON is ON		During first 10' of Drying Phase & UVON is ON		After first 10' of Drying Phase & UVON is ON		Program is end & UVON is ON		If machine is turned off and on, UVON will not be ON	
	ON	OFF	ON	OFF	ON	OFF	ON	OFF	ON	OFF	ON	OFF	ON	OFF
UV-A led	x	x	x	x	x	x	x	✓	x	x	x	x	x	x
Ionizer leds	x	x	✓	x	✓	x	✓	x	✓	x	✓	x	x	x

X: led is off

✓:led is on

For 45 cm Slim BLDC models:

For only these slim models, since UV is driven same pin with DC fan, UV led is on during the fan is active on the drying phase with fan as default. During the drying without fan, UV led is off. (UV led lighting does not depend on whether it is activated or deactivated by pressing related button.)

SAVE POWER MODE

There are 3 modes as SP0, SP1 and SP2. Mode is changed from menu.

For S1x 60 cm models:

For S2x 60 cm models

For S3x 60 cm models:

How to change from "SAVE POWER MODE" to "NORMAL MODE":

Press two specified buttons simultaneously for 3 seconds as indicated on the above user interfaces. "ILO" will be shown on the display (top and front) for 2 seconds to show the "Normal Mode" is selected for inner light option. After "Normal Mode" is selected, the inner light will be ON as long as the machine is energized and door is open.

ii. How to change from "NORMAL MODE" to "SAVE POWER MODE":

Press two specified buttons simultaneously for 3 seconds as indicated on the above user interfaces. "IL1" will be shown on the display (top and front) for 2 seconds to show the "Eco Mode" is selected for inner light option. Also inner light blinks to show this selection is activated. After "Eco Mode" is selected, the inner light will be ON for 4 minutes after the door is opened and then turns OFF. Then display returns its usual position. (Ex: 3" Pn, 1" time). If any user intervention occurs such as pressing buttons, Eco Mode cycle starts from beginning (inner light is ON for 4min and then becomes OFF again).

Note: For S1 models withOUT display; when inner light mode is changed, leds shown below table will be on.

I1 models withOUT display Inner light	P1	P2	1/2
ECO mode -> Normal mode	X	X	
Normal mode -> ECO mode	X	X	X

Infoled

Infoled 2.1 Behavior

In all built-in models (60-45cm):

- While the program is running, the red LED lights continuously. When the program is finished, the green LED lights continuously.
- If no action is taken at the end, the green LED turns off with auto off after 15 minutes. During this period, if any button is pressed on the machine, the machine goes to the ready state and the green led turns off.
- During the cancellation process, the red LED blinks at 1 second intervals.
- In case of error, the red LED flashes at 0.5 second intervals.
- When the door is opened, the infoleds turn off, only when the door is in the finished state, the green led stays on.

InfoLED 2.1	in ready position	While Prg, SP is running, before Okam opens, while ion or delay is active	When the door is opened while working	When the door is opened while the ion is active	After the program ends, cancel, Ion, SP (When the door is opened in the +done state)	At the time of cancellation	In case of error	End Test1 after 10.sec	EndTest2	End Test3 with the door closed	End Test3 with the door open
Red	fireproof	lights up	fireproof	Blinks as breath	fireproof	Flashes at 1 second intervals	Flashes at 0.5 sec intervals	lights up	fireproof	fireproof	lights up (with ion led)
Green	fireproof	fireproof	fireproof	fireproof	lights up	fireproof	fireproof	lights up	fireproof	lights up	fireproof

- IL2.1 shows the same behavior as the program run during the service test, the green led lights up when the service test is over. If the machine goes into error during the service test, the red led lights up at 0.5 second intervals.
- In End test 1, after the 10th second, green and red light together, in End test 2, the infoleds do not light, in End Test 3, when the door is closed, the green led and when the door is open, the red led lights up together with the ion led.

BM05 Infoled 2.0 and Infoled 2.1 outputs		
CN11.2	7V	Ion Led+Infoled2.0 (multiplexed via Infoled card)
CN8.2	GND	Infoled2.0 GND
CN8.3	Rinse read	Infoled 2.1 switching
CN9.2	-5V	Infoled2.1 feeding

AUTODOOR OPEN SYTEM

Energy save option is not selectable at any time. During program, energy save option cannot be cancelled or cannot be added. If user presses energy save button during program, the buzzer gives a long sound that is activated to warn that this is not a valid command.

- o When option is selected, The door is opened by the Door Open System at the end of washing program.
- o Program in the 1 (Last 1 minute before program finishing)

Start to count 2 minutes in the memory

TY4 triac is driven by microcontroller and door open system is energized

The buzzer gives sound (1"ON + 4"OFF) until auto door mechanism open the door

There is 1 on the display during this time.

- o When Auto door mechanism open the door

TY4 triac is not driven by microcontroller

There is 0 on the display.

Stop to count 2 minutes in the memory

- o If Auto door is not opened in 2 minutes

TY4 triac is not driven by microcontroller

There is 0 on the display.

FC failure code is saved to memory

Machine must be ON position during activation and deactivation of door open system. Position of the door (open/close) is not important to activate/deactivate the system. But during washing cycle, it is not enabled to activate /deactivate to this feature.

- How the system works:

- o The unlocked door goes down.
- o TY4 triac are used to control of auto door mechanism.

- o The mechanism stops the door at 10 cm opening.

- Benefits:

- o At hot rinse step, the water is heated up to reasonable values and A class drying is provided by letting the steam flow away to air from the dishwasher.
- o Some of required heating energy for drying is saved at hot rinse step.

Factory setting for auto door open system is set to "OFF" except Eco program

Factory setting for Eco program is set to "ON".

Auto door option button is illuminated (ON) when user selects at only Eco program by each pressing program selection button.

In Eco program, Auto door must be opened in every cycle until the end user unselect the Energy save option for Eco program. That is to say, In first cycle of Eco or other cycles, Auto door system must be performed (ON) until end user deactivate Auto door system.

Due to Eco design requirements, each energized of the machine (by pressing ON/OFF) Eco program must be fixed as default, energy save option led must be ON(only valid for Eco) and the options that are chosen before will be cancelled.

For ex: when user power OFF/ON→ Eco program is fixed as default, energy save option led is ON.

AUTODOOR CONTROL TEST

For S2x and S3x models:

Open the door of the machine. Switch-on the dishwasher. Press Menu button immediately and hold it down for 5". After 5", machine enters secret menu. Then, program selection(for S2 models) or delay buttons(for S3 models) are used to surfing through. In auto door control test, display shows "dCO" characters. Then press Start/Pause button and close the door to start the test.

To start the Autodoor Test;

1. Open the door, and turn the machine OFF
2. By pressing Menu button turn on the machine and continue to press for 5 seconds to recognize Secret Menu
3. Select dCO
4. Press Start/Pause button and close the door

· Program in the "1" (Last 1 minute before program finishing)

- o Start to count 2 minutes in the memory
- o TY4 triac is driven by microcontroller and door open system is energized
- o The buzzer gives sound (1"ON + 4"OFF) until auto door mechanism open the door
- o There is 1 on the display during this time.
 - When Auto door mechanism open the door
- o TY4 triac is not driven by microcontroller
- o There is 0 on the display.
- o Stop to count 2 minutes in the memory

- If Auto door is not opened in 2 minutes
 - o TY4 triac is not driven by microcontroller
 - o There is 0 on the display.
 - o FC failure code is saved to memory

-Test can be finished by pressing On/Off button.



BLDC MOTOR CONTROL TEST

To start the BLDC motor test:

1. Open the door, and turn the machine OFF
2. By pressing Menu button turn on the machine and continue to press for 5 seconds to recognize Secret Menu
3. Select Pc
4. Press Start/Pause button and close the door

To increase RPM values press Up Program button(for S2 series) or Delay + button(for S3 series), to decrease RPM values press Down Program button(for S2 series) or Delay - button(for S3 series).

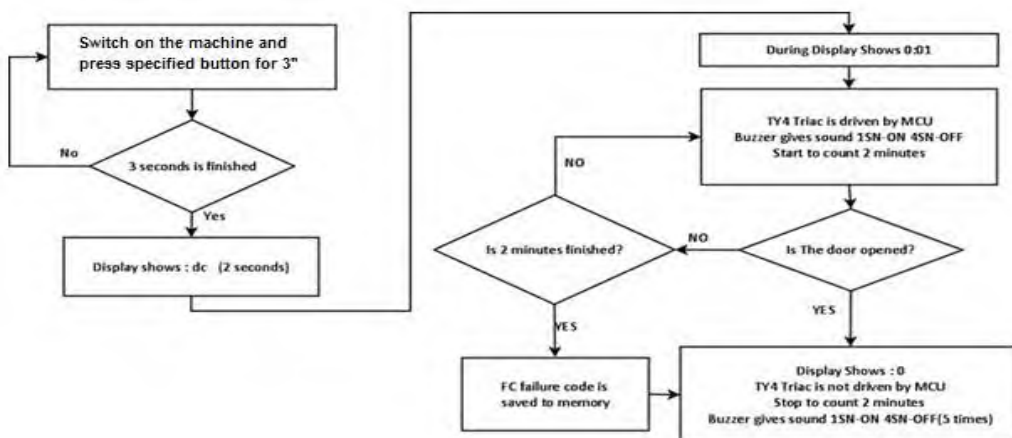

Rpm values can be raised or decreased one by one.
Test can be finished by pressing On/Off button.

For 60 cm models:

Open the door of the machine. Switch-on the dishwasher. Press 1/2 and Options button immediately and hold them down for 5". After 5", display shows "Pc" (means that Pump control) characters during 2 sec, then "20" characters appear and BLDC motor start performing with 2000 rpm. To increase RPM values press Options, to decrease RPM values press 1/2 button.

Open the door of the machine. Switch-on the dishwasher. Press 1/2 and Options button immediately and hold them down for 5". After 5", display shows "Pc" (means that Pump control) characters during 2 sec, then "20" characters appear and BLDC motor start performing with 2000 rpm. To increase RPM values press Options, to decrease RPM values press 1/2 button.

Press "1/2" button to decrease RPM values by hundred from 3400 to 2000.(34,33,32,...,20)

For 45 cm models:

Open the door of the machine. By pressing Delay and 1/2 buttons simultaneously switch-on the dishwasher, when machine is on continue to press Delay and 1/2 buttons buttons for 5". After 5", display shows "Pc" (means that Pump control) characters during 2 sec, then "20" characters appear and BLDC motor start performing with 2000 rpm.

Press "1/2" button to increase RPM values from 2000 to 3400.(20,21,22,...,34)

Press "Delay" button to decrease RPM values by hundred from 3400 to 2000.(34,33,32,...,20)

For 15x 60 cm models:

Open the door of the machine. By pressing Upper/Lower basket button button switch-on the dishwasher, when machine is on continue to press Upper/Lower basket button button for 5". After 5", display shows "Pc" (means that Pump control) characters during 2 sec, then "20" characters appear and BLDC motor start performing with 2000 rpm.

Press "Extra Silent" button to increase RPM values from 2000 to 3400.(20,21,22,...,34)

Press "Extra Dry" button to decrease RPM values by hundred from 3400 to 2000.(34,33,32,...,20)



Rpm values can be raised or decreased one by one.

Test can be finished by pressing On/Off button.

WATER SAVE CONTROL TEST

To start the Water Save Control test;

1. Open the door, and turn the machine OFF
2. By pressing Menu button turn on the machine and continue to press for 5 seconds to recognize Secret Menu
3. Select rc

4. Press Start/Pause button and close the door

After 5", display shows "rc" (means that recovery control) characters during test. The buzzer gives sound (1"ON + 4"OFF) during test except "buzzer sound finishes step" in below diagram.

Pressing any button does not affect the test and any invalid buzzer sound is not heard while water save algorithm in below diagram is continuing.

At the end, buzzer gives long sound.

Test can be finished by pressing On/Off button.

Notes:

1. If a program is started after Eco/Eco5.4lt program, water inside the water save tank is drained at the beginning of the program.
2. After water save tank is full, user must press Program button to continue the test. If Program button is not pressed, test does not continue.
3. If machine turns off/on while test is being executed, machine turns to standby position.

During the test below algorithm is applied:

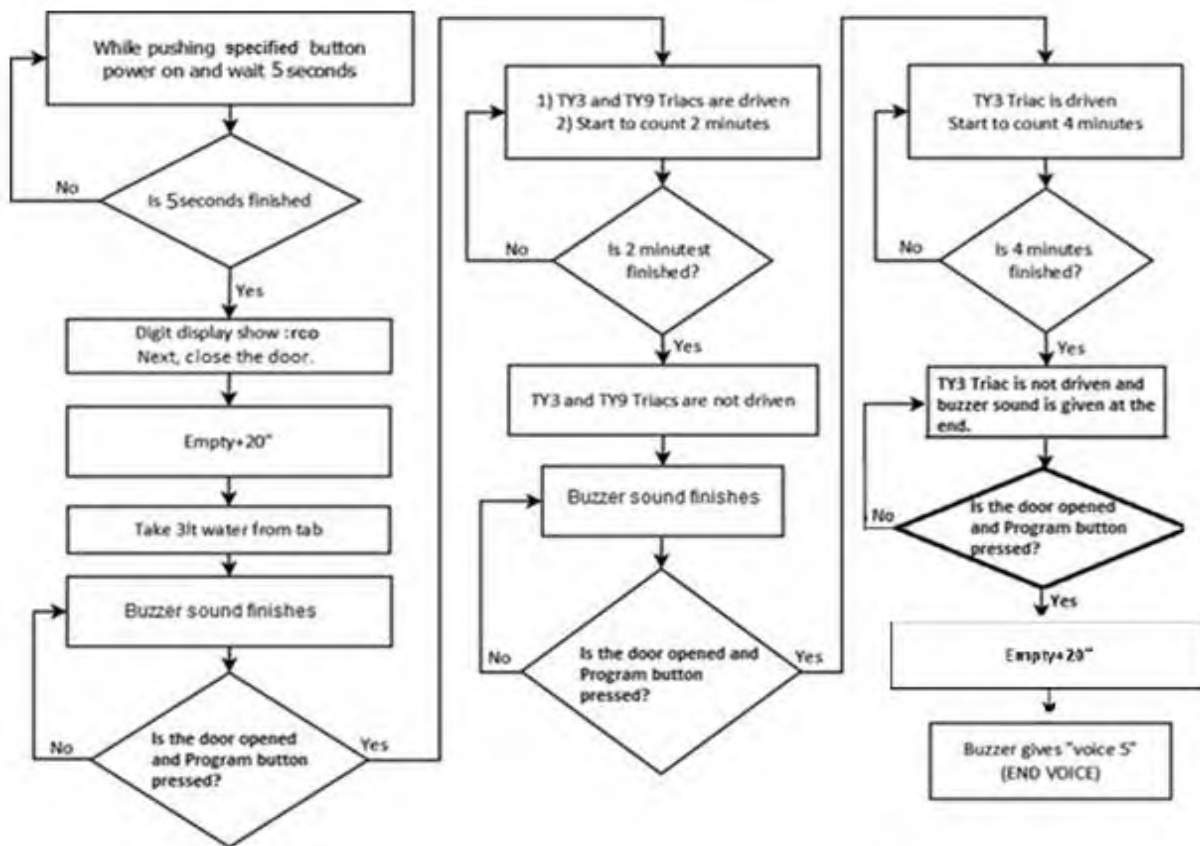

VOICE CONTROL TEST

For S1x 60 cm models:

For S2x 60 cm models:

For S1x, S2x 45 cm models:

For S 60, 45 cm models:

First energize the machine via main switch (if it is in OFF position).

Press two specified buttons simultaneously for 3 seconds as indicated on the above user interfaces.

If voice controlling is done at first time, at the end of 3 seconds, "S3" is shown on the display and Buzzer gives a long sound. (level of 3) (Factory setting is set to "S3")

User can increase or decrease the voice level with specified buttons. The characters must be as follow;

By each pressing button which specified right side of the combination:

- Display screen changes S0 to S3
- Level of sound increases step by step

By each pressing button which specified left side of the combination:

- Display screen changes from S3 to S0
- Level of sound decreases
- "S0" level means all voices are off

Note: For S1 models withOUT display; when voice level is changed, leds shown below table will be on.

Voice Levels	1/2	3h	6h	9h
S3	X	X	X	X
S2		X	X	X
S1			X	X
S0				X

To save the determined voice level and exit voice control mode, switch off the machine.

After program finished, buzzer sounds for 3 times at 5 minutes intervals.

ERROR DEFINITIONS

S SERIES ERROR CODES TABLE

Old Description	Short Description	Short Description with code	P1	P2	1/2	3h	6h	Display
OverFlowError	<i>Temporary Overflow</i>	<i>F0: Overflow</i>	-	Blink	Blink	Blink	Blink	F0
LeakageError	<i>Leakage</i>	<i>F1: Leakage</i>	-	Blink	Blink	-	Blink	F1
DrainingTimeOut	<i>Inability to Discharge Water</i>	<i>F2: No Discharge</i>	-	-	Blink	Blink	Blink	F2
PresenceofFlowMeterImpulses	<i>Continuous Water Inlet</i>	<i>F3: Continuous Water</i>	-	Blink	-	Blink	Blink	F3
AbsenceOfFlowMeterError	<i>Flow Meter Error</i>	<i>F4: Flow Meter</i>	Blink	Blink	-	Blink	Blink	F4
AbsenceOfFlowMeterEmptyLevelError	<i>Pressure System Error (fill+wash step)</i>	<i>F5-1: Pressure-fill+wash"</i>	Blink	Blink	-	-	Blink	F5

ReFillTimeOutError	<i>Pressure System Error (wash step)</i>	<i>F5-2: Pressure-wash</i>	Blink	Blink	-	-	Blink	F5
3TimesF0	<i>3 times F0 in the same phase</i>	<i>F5-3</i>	Blink	Blink	-	-	Blink	F5
LevelEmptyWithoutFlowMeterImpulses	<i>No Water Inlet</i>	<i>FF-1: No Water</i>	Blink	Blink	Blink	Blink	-	FF
RarelyFlowMeterImpulsesError	<i>Low Water Flowrate</i>	<i>FF-2: Low Water Flowrate</i>	Blink	Blink	Blink	Blink	-	FF
NTC open or short-circuit	<i>NTC Error</i>	<i>F6: NTC</i>	Blink	-	-	Blink	Blink	F6
Overheating	<i>Overheating</i>	<i>F7: Overheating</i>	Blink	-	Blink	-	Blink	F7
Unsuccessful heating	<i>Unsuccessful Heating</i>	<i>F8: Heating</i>	Blink	-	Blink	Blink	Blink	F8
DiverterOpenedError	<i>Diverter Error</i>	<i>F9: Diverter</i>	-	-	-	-	-	F9
Parameter set salt incorrect	<i>No Salt Level Adjustment</i>	<i>SE: No Salt Adjustment</i>	Blink	Blink	Blink	-	Blink	SE
TurbiditySensorError	<i>Turbidity Sensor Error</i>	<i>FA: Turbidity</i>	Blink	-	-	Blink	-	FA
AutoDoorError	<i>Auto Door Error</i>	<i>FC: Auto Door</i>	Blink	Blink	Blink	Blink	Blink	FC
HighVoltageError	<i>High Voltage</i>	<i>HI: High Voltage</i>	Blink	Blink	Blink	-	-	HI
LowVoltageError	<i>Low Voltage</i>	<i>LO: Low Voltage</i>	-	Blink	Blink	Blink	-	LO
	<i>Incompatible Mainboard and Display Board</i>	<i>EnA: Card Incompatibility</i>						

S SERIES ERROR CODES EXPLANATIONS

Display	Shown Only Service Test	Test Method	Algorithm of Failure	Root Cause of Failure	Action
F0	YES	Floater micro switch is active between 6-10 seconds.	If floater activation duration is between 5 and 41 seconds in the program.	inclined positioning of dishwasher, mechanical impact from outside such as hard opening or closing the door etc Electronic board failure.	F0 is saved in memory. After floater activation is lost, Empty + Refill algorithm is applied and program continues.
F1		Floater micro switch is active above 41 seconds; drain pump is disconnected (because of machine's cable connection)	If floater activation duration is above 41 seconds in any case.	Water leakage into the basement Floater, floater switch is broken or disconnected. Drain pump is disconnected. (because of	F1 is saved in memory and F1 error is shown on the display.

				machine's cable connection) Electronic board failure.	
F2		Drain pump is disconnected and an external drain pump is connected, then a program is started.	When in drain step (drain pump and circulation pump on), if pressure does not drop in 180".	Water discharge hose or filters are clogged External material in drain pump impeller volute Drain pump is broken Electronic board failure.	F2 is saved in memory, machine goes to failure routine. As failure routine circulation and drain pump works 20 seconds, F2 is shown.
F3		Water inlet valve's cable is disconnected and the valve is worked by external 220V in the fill step or washing step of a program.	During water inlet step; after water inlet valve is closed, if flowmeter still gives impulses more than 500 ml.	Water inlet valve is broken, or external particle stuck in valve. Electronic board failure.	Drain pump is activated as empty+20". After that, machine tries to water inlet again and after water inlet valve is closed, if flowmeter gives impulses more than 500 ml again, F3 is saved in memory. Then, water inlet valve is on for 12 seconds and off for 12 seconds 5 times. After 5 tries, F3 failure is shown. Then drain pump is off 100 seconds, on for 60 seconds periodically. Explained with block diagram on Failure Routines Information Document.
F4	YES	Flowmeter is disconnected and an external flowmeter is connected, then a program is started.	If there is no impulses from flow meter during 50" time out of fill step and then 60" time out of fill&wash step and pressure switch is active in fill&wash step.	Flow meter is broken or disconnected Electronic board failure.	F4 is saved in memory. Water level is controlled over time out which is 50"+60". In the regeneration process, machine should fill water over timeout which is 24*liter (For example water inlet valve should work 12 seconds for 0.5 liter water.)

F5		<p>1)The power of the machine is cut off. The connector of the washing motor is removed, the machine is energized and the program is started.</p> <p>2)The power of the machine is cut off. The connector of the pressure switch is disconnected and connected to an external micro switch. The machine is energized and the program is started.</p>	<p>If there is no pressure at the end of fill & wash step, 40'' timeout duration starts while filling water. If pressure switch still is not active during timeout duration which is 40''. Explained with block diagram on Failure Routines Information Document.</p>	<p>Circulation pump or pressure switch is broken or disconnected. Electronic board failure.</p>	<p>F5 is saved in memory, water is drained, F5 is shown.</p>
F5		<p>1)The power of the machine is cut off when the program is in the washing step. The connector of the washing motor is removed, the machine is energized and the program continues where it left off.</p> <p>2)The power of the machine is cut off the program is in the washing step. The connector of the pressure switch is disconnected and connected to an external micro switch. The machine is energized and the program continues where it left off.</p>	<p>If there is no pressure longer than 5" in washing steps(wash and wash+heat steps).</p>	<p>Circulation pump or pressure switch is broken or disconnected. Electronic board failure.</p>	<p>Water is drained. Water inlet and control algorithm(re-fill routine) is repated for max 3 extra water inlet. (After the error is occurred 3 times in the same phase of the program) If there is still error, F5 is saved in memory, water is drained and F5 is shown.</p>
F5		<p>In the same phase of the washing, floater micro switch is active between 6-10 seconds 3 times.</p>	<p>If floater activation duration is between 5 and 41 seconds, F0 error is saved in memory.</p>	<p>Inclined positioning of dishwasher, mechanical impact from outside such as hard opening or closing the door etc. Counting missing pulse and filling much water. Electronic board failure.</p>	<p>Water is drained. Water inlet and control algorithm(re-fill routine) is repated for max 3 extra water inlet. If there is still error, F5 is saved in memory, water is drained and F5 is shown.</p>

FF		Water tap is closed	In water fill step, if there is no flow meter impulse for 150" and no pressure	Water tap is closed, water inlet hose is wrinkled, water is cut off. Inlet valve is broken or disconnected. Electronic board failure.	FF is saved in memory, water is drained, FF is shown
FF		Water tap is opened with low water pressure.	If machine does not fill 2,5 liter water within the time out 420" in fill step	Water tap is closed or water inlet hose is clogged Electronic board failure.	FF is saved in memory, water is drained, FF is shown
F6		When the program is started with open or short-circuited NTC.	If NTC sense current is maximum or no current, whenever measured.	Open or short-circuited heater sensor (NTC) component. Electronic board failure.	F6 is saved in memory, water is drained, F6 is shown
F7		Power of the machine is cut off. NTC connector is removed. Instead of it, external 6.5kΩ potentiometer is connected. The machine is energized and the program is started.	If water temperature is equal or above 77°C	In case the heater stop command can not be received and continues to operate. Electronic board failure.	F7 is saved in memory, water is drained, F7 is shown
F8		Power of the machine is cut off. Heater's connector is removed. The machine is energized and the program contains heating step is started.	During the heating phases, first 2 minutes there is no measuring the temperature. After that, if water temperature increases less than 2°C in 5 minutes intervals	Heater is disconnected or heater sensor (NTC) is broken. Electronic board failure.	F8 is saved in memory, program continues without heating, F8 is shown at the end of the program.
F9		Power of the machine is cut off. Diverter's connector is removed. The machine is energized and the program is started.	If diverter valve is on during 30" and diverter sensing doesn't change	Diverter is broken or disconnected Electronic board failure.	F9 is saved in memory, water is drained, F9 is shown
SE	YES	-	If salt parameter was not set.	-	SE error is saved in memory until salt adjustment.
FA	YES	Power of the machine is cut off. Turbidity sensor's connector is removed. The machine is energized and the program is started.	If turbidity sensor values are not seen by mainboard	Turbidity sensor is broken or disconnected. Electronic board failure.	FA error is saved in memory.
FC	YES	Autodoor connector is removed.	When the auto door function is activated, if door is not opened automatically at the end	Auto door mechanism is broken. Auto door opener motor is broken or disconnected.	FC error is saved to memory.

			of the program in 2 minutes.		
HI	Main supply voltage setting.		When main supply voltage is above 285V for longer than 3 hours. (for 110V models, when main supply voltage is above 145V (then 135-145VAC) for longer than 3 hours.)	-	When main supply voltage is above 285V, machine stops as soon as possible. When main supply voltage is above 285V for longer than 10 seconds, HI error is saved to memory. If it goes below 275V, machine works again. But when main supply voltage is above 285V for longer than 3 hours, HI shown in display.
LO	Main supply voltage setting.		When main supply voltage is below 145V for longer than 3 hours. (for 110V models, Low voltage failure is not available)	-	When main supply voltage is under 145V, machine stops as soon as possible. When main supply voltage is under 145V for longer than 10 seconds, LO error is saved to memory. If it goes above 155V, machine works again. But when main supply voltage is under 145V for longer than 3 hours, LO shown in display.
EnA	-		When the mainboard and display board softwares are not compatible to work with each other. Communication problem between main and display board during first energizing the display board.	-	Shown when machine is ON.

Note:

The error must be controlled in every heating steps longer than 7 minutes. Also, for example in the first heating step F8 error is detected and saved in memory, program continues. In the second heating step, F8 is controlled again and if there is no F8 error anymore, F8 error code in the memory is deleted. Also, if power fail or open/close door is occurred in heating steps, F8 failure routine restarts to beginning.

FAILURE ROUTINES

FAILURE ROUTINES			
No	Name	Exit of failure state	Service Call
1	Switch door open	Door closing	NO
2	Delay after door closing	7" delay before restart prg in heating step	NO
3	Overflow Leakage	Overflow signal gets off	NO
		OFF/ON	YES
4	Draining time out	OFF/ON	YES
5	Presence of Flow meter impulses	Flow Meter signal gets off.	NO
		OFF/ON.	YES
6	Absence of Flow meter impulses	Pressure switch on Full.	NO*
		Pressure switch on Empty. OFF/ON	NO/YES
7	Level Empty	Level doesn't reach full	NO/YES
8	Re-Fill	3 Re – fill in the same washing step	NO/YES
8	NTC ca/cc	OFF/ON	YES
8	Overheating	OFF/ON	YES
10	Unsuccessful heating	OFF/ON	YES
11	Diverter opened	OFF/ON	YES
12	CK Parameters	OFF/ON	YES
13	High Voltage Failure	OFF/ON	YES
14	Low Voltage Failure	OFF/ON	YES

Cycle could be executed with a filling time.

Failure Routine

If a failure is recognized:

- Stop all devices
- Stop program flow.
- Drain Empty + 30" with circulation pump on

If the failure requires the termination of the washing program:

- Stop all the devices.
- Start to visualize the failure code.

If the failure doesn't require the termination of the washing program:

- Stop all the devices.
- Re-Start the washing program.

If it is necessary it performs the Re-Fill routine

Re-Fill Routine

After a forced drain (ex: a failure routine) if the dishwasher was in wash before the drain it performs the re-fill routine:

- Inlet Valve ON + circulation pump OFF to load 3l (time out 420")
- When the first load step is finished, Inlet Valve ON + circulation pump ON to load 1l (time out 100")
- Return to the washing cycle

Notes:

- Just in failure routines, drain pump is active even if the door is open.
- In failure routines or after machine gives the error code; if machine is turned off/on, machine turns on in ready state.
- In S3 models; when the machine gives an error, left display leds do not blink.

SERVICE TEST

Only service can execute this procedure.

To start the Service test;

1. Open the door
2. Switch ON the machine by pressing on/off button.
3. Immediately after, press the Menu Button for 5 sec to recognize Secret Menu for button models. (For touch models by pressing Menu button switch on the machine and continue press Menu button for 5 seconds)
4. Select SP
5. Press Start/Pause button and close the door

After closing the door, SP is shown on the front display.

When "Service test" is recognized

- All leds are ON, SP is visualized on display and service test starts. During the first 6" of test, if a failure code is stored in memory, its codification blinks. If there is no error" –" is shown on the display. Also at the end of the test if an error occurs its error code blinks. (For models without display: when service test is recognized, all leds blink thrice)

Close the door. Then service program will start automatically. (After showing the last error code for 6sec like in the freestanding models- "888" will be shown until the end of test program if the door is closed)

If there is no error at the end of the service test, the machine passes to the end state.

After the error is occurred, if the service test is not finished without error(e.g. exiting from service test with

on/off button) and then service test is started again; error code is shown on the display at the beginning of the service test.

Also at the end of the test if an error does not occur during service test and completes the cycle without error, any codification is never shown. The last failure code is never shown anymore. Actually, last failure code is erased after completing the test successfully.

Step		Time	Tested Load
0	Show code	6"	Before start, the code of last error is visualized (see below)
1	Drain	6"	Drain pump.
2	Fill (3l/2,5l)*	~ 1'	Flow meter; Inlet Valve;
3	Fill + Wash (0,5/1lt)**		Flow meter; Inlet Valve; Pressure Switch;
4	Turb. Calibration	~ 30"	Turbidity Calibration(If model has turbidity sensor)
5	Wash	1'	Circulation pump; detergent dispenser. Detergent dispenser is active for 5 seconds between 10-15th seconds.
6	Wash + Heat ***	5'	Heater (PSW); NTC; diverter (position).
8 9	Reg. Valve + Turbo Fan	1'	Regeneration Valve + Turbo Fan
10	(Resin wash) water inlet valve + drain pump	~1' 20"	Water inlet valve (3 lt)+drain pump;to wash resin and to drain out any possible salt from the machine.
11	Drain	Empty+20"	Drain pump + circulation pump (until pressure switch empty level)

* 2,5lt in models with diverter - 3lt in models without diverter

** 1lt in models with diverter - 0.5lt in models without diverter

*** In service test the unsuccessful heating failure routine works with reduced time of recognize (first measure at 2'20", second measure at 4'20"). If water temperature increases less than 1°C in this 2 minutes, it goes to the F8 failure.

In the service test fill+wash step, the divisor only works on the lower sprinkler.

If during the service test, the door is opened, "SP" is shown.

To reset the service test, press On/Off button or plug out and then plug in.

To cancel the service test, press Start/Stop button for 3 seconds.

Also at the end of the test, if an error does not occur, "0" is visualized. Machine will be at end position. If any button is pressed, machine goes ready position.

- Just F0, F4 and F8 errors are shown at the end of the service program. 3 F0 and 3 F5 errors are shown after 3 refill when the failure is recognized.

Note: If user did not set water hardness level before service test, "SE" is shown at the beginning and end of service test.

- During Service Test, Infoled 2.1 works same as the program running.

SERVICE TEST SPECIFICATIONS

Note: In S3 models, program number is not shown on the display.

Note: In S Usa models, after start/pause button is pressed; if the door is not closed in 4 seconds, SP changes as P on the display and it means pause.

SELECT SERVICE TEST, CLOSE DOOR WITHOUT PRESSING START/PAUSE BUTTON

COMMANDS	Top Display	Front display	Flow ind. on Front display	End icon on Top Display	Start/Pause Led
Switch on	Duration of program / Program number	None	OFF	OFF	OFF
Select SP from Secret Menu	SP	None	OFF	OFF	
Door closed(without pressing Start/Pause)	None	None	OFF	OFF	

Note: When SP is selected but start/pause button is not pressed then door is closed, machine gives invalid buzzer sound.(2 short beeps)

STARTING SERVICE TEST

COMMANDS	Top Display	Front display	Flow ind. on Front display	End icon on Top Display	Start/Pause Led
Switch on	Duration of program / Program number	None	OFF	OFF	OFF
Select SP from Secret Menu	SP	None	OFF	OFF	OFF
Door closed after pressing Start/Pause to start SP(shorter than 4" for USA (while counting as 4 3 2 1))	SP	SP	OFF	OFF	After pressing Start/Pause -> ON After door closed -> OFF

OPENING AND CLOSING DOOR DURING SERVICE TEST

During the Service Test if the door is opened and re-closed without any modifications on the program button the program continues. Washing program re-starts after 8" if the measured temperature is equal or more than 45°C.

COMMANDS	Top Display	Front display	Flow ind. on Front display	End icon on Top Display	Start/Pause Led
Door open	SP	None	OFF	OFF	ON
Door closed(shorter than 4" for USA (while counting as 4 3 2 1))	SP	SP	OFF	OFF	OFF

TERMINATION OF SERVICE TEST(END OF SERVICE TEST)

COMMANDS	Top Display	Front display	Flow ind. on Front display	End icon on Top Display	Start/Pause Led
End of program(before door open)	"0"	"0"	End icon ON	ON	OFF
Door open	"0"	None	OFF	ON	
Door closed	"0"	"0"	End icon ON	ON	

CANCELLING OF A PROGRAM(DURING PROGRAM)

COMMANDS	Top Display	Front display	Flow ind. on Front display	End icon on Top Display	Start/Pause Led
Door open	SP	None	OFF	OFF	ON
Press 3" Start/Pause button	"3 2 1"	None	OFF	OFF	ON
At the end of the 3"	"0:01"	None	OFF	Blink	ON
Door closed(After pressed S/P and shorter than 4" for USA(while 0:01 blinks for 4 seconds))	"0:01"	"0:01"	Dry icon ON	OFF	OFF
During canceling	"0:01"	"0:01"	Dry icon ON	OFF	OFF
At the end of the canceling	"0"	"0"	End icon ON	ON	OFF

Short Cancellation

Cancellation is started by pressing the Start/Pause button for 3 seconds while the program is running or in the ready position. Cancellation is stopped by pressing the Start/Pause button once while in the cancellation step. Short cancellation is made by on/off from the machine (standby) or from the main power.

HOW IT COMES AFTER THE SHORT CANCELLATION:

It comes on ready state."

WASHING SPECIFICATIONS AND PROGRAMS

Note: In S3 models, program number is not shown on the display.

OPENING DOOR, SELECTING PROGRAM AND CLOSING DOOR(BEFORE PROGRAM STARTS)

COMMANDS	Top Display	Front display	Flow ind. on Front display	End icon on Top Display	Start/Pause Led
Switch on	Duration of program / Program number	None	OFF	OFF	OFF
Select program(change program)	Duration of program / Program number	None	OFF	OFF	
Door closed(without pressing Start/Pause)	Duration of program / Program number	Duration of program / Program number	OFF	OFF	

Note: When machine is switched on, 3 short beeps are heard. When it is turned off, buzzer gives long sound.

Note: When program is selected but start/pause button is not pressed then door is closed, machine gives invalid buzzer sound.(2 short beeps)

SELECTING AND STARTING PROGRAM AT POWER ON(BEFORE PROGRAM STARTS)

COMMANDS	Top Display	Front display	Flow ind. on Front display	End icon on Top Display	Start/Pause Led
Switch on	Duration of program / Program number	None	OFF	OFF	OFF
Select program(change program)	Duration of program / Program number	None	OFF	OFF	OFF
Door closed after pressing Start/Pause(shorter than 4" for USA (while counting as 4 3 2 1))	Duration of program	Duration of program	Washing icon ON	OFF	After pressing Start/Pause -> ON After door closed -> OFF

OPENING AND CLOSING DOOR DURING PROGRAM(NOT IN DRY STEPS)

During the program if the door is opened and re-closed without any modifications on the program button the program continues. Washing program re-starts after 8" if the measured temperature is equal or more than 45°C.

COMMANDS	Top Display	Front display	Flow ind. on Front display	End icon on Top Display	Start/Pause Led
Door open	Duration of program / Program number	None	OFF	OFF	ON
Door closed(with modification or longer than 4" for USA (while counting as 4 3 2 1))	Duration of program / Program number	Duration of program / Program number	Washing icon Blink	OFF	After pressing S/P -> Blink After pressing S/P again -> ON After door closed -> OFF
Door closed(without modification or after pressing Start/Pause with modification)	Duration of program	Duration of program	Washing icon ON	OFF	OFF

OPENING AND CLOSING DOOR DURING PROGRAM (IN DRY STEPS)

COMMANDS	Top Display	Front display	Flow ind. on Front display	End icon on Top Display	Start/Pause Led
Door open	Duration of program / Program number	None	OFF	OFF	ON

Door closed	"0"	"0"	End icon ON	ON	OFF
-------------	-----	-----	-------------	----	-----

OPENING AND CLOSING DOOR DURING PROGRAM (IN REGENERATION FIRST STEP)

During regeneration first step: if the door is opened and re-closed, the program continues.

COMMANDS	Top Display	Front display	Flow ind. on Front display	End icon on Top Display	Start/Pause Led
Door open	Duration of program / Program number	None	OFF	OFF	ON
Door closed(shorter than 4" for USA (while counting as 4 3 2 1))	Duration of program	Duration of program	Dry icon ON	OFF	OFF

OPENING AND CLOSING DOOR DURING PROGRAM(IN REGENERATION SECOND STEP)

During regeneration second step: if the door is opened and re-closed, the program ends.

COMMANDS	Top Display	Front display	Flow ind. on Front display	End icon on Top Display	Start/Pause Led
Door open	Duration of program / Program number	None	OFF	OFF	ON
Door closed	"0"	"0"	End icon ON	ON	OFF

TERMINATION OF A PROGRAM(END OF PROGRAM)

COMMANDS	Top Display	Front display	Flow ind. on Front display	End icon on Top Display	Start/Pause Led
End of program(before door open)	"0"	"0"	End icon ON	ON	OFF
Door open	"0"	None	OFF	ON	
Door closed	"0"	"0"	End icon ON	ON	

- When the program is completed, End led will be on and the buzzer will be activated (1sec sound, 4sec wait until total time 21sec is completed [total 5 bip sound]) If the door is not opened by the user the activation of the buzzer will continue until 15 min passed which means that in first 5min : (1sec sound + 4sec wait) x5) signal / In the second 5min: (1sec sound + 4sec wait) x5) signals and in the last 5min: (1sec sound + 4sec wait)x5) signals, then the routine is stopped.

CANCELLING OF A PROGRAM(DURING PROGRAM)

COMMANDS	Top Display	Front display	Flow ind. on Front display	End icon on Top Display	Start/Pause Led
Door open	Duration of program / Program number	None	OFF	OFF	ON
Press 3" Start/Pause button	"3 2 1"	None	OFF	OFF	ON
At the end of the 3"	"0:01"	None	OFF	Blink	ON
Door closed(After pressed S/P and shorter than 4" for USA (while 0:01 blinks for 4 seconds))	"0:01"	"0:01"	Dry icon ON	OFF	OFF
During canceling	"0:01"	"0:01"	Dry icon ON	OFF	OFF
At the end of the canceling	"0"	"0"	End icon ON	ON	OFF

- If tablet option is on and running program is not compatible with tablet, tablet led does not light up during the cancel process and after the cancel process. After that, if a button is pressed, it goes to ready state and tablet led lights up.

SELECTING AND STARTING PROGRAM AT POWER ON WITH START DELAY

COMMANDS	Top Display	Front display	Flow ind. on Front display	End icon on Top Display	Start/Pause Led
Switch on	Duration of program / Program number	None	OFF	OFF	OFF
Select program(change program)	Duration of program / Program number	None	OFF	OFF	OFF
Select delay (press delay button)	Duration of program / Program number / Delay time	None	OFF	OFF	OFF
Door closed (without pressing Start/Pause)	Delay time	Duration of program / Program number / Delay time	OFF	OFF	OFF
Door closed after pressing Start/Pause(shorter than 4" for USA (while counting as 4 3 2 1))	Delay time	Duration of program / Delay time / Delay icon ON	OFF	OFF	After pressing Start/Pause -> ON After door closed -> OFF

During the delay time	Delay time	Duration of program / Delay time / Delay icon ON	OFF	OFF	OFF
End of delay time	Duration of program	Duration of program	Washing icon ON	OFF	OFF

Note: When delay is selected but start/pause button is not pressed then door is closed, machine gives invalid buzzer sound.(2 short beeps)

MODIFICATION OF A PROGRAM WITHOUT RESET

Notes:

While the program is running with the option, if the program is stopped, changed and the same program is selected again, the previous selected option is active.

The option cannot be selected without stopping the program while it is running.

While the program is running, after the door is opened, the option cannot be selected.

While the program is running, machine gives buzzer sound when the option is tried to be activated. (For models with buzzer)

Machine gives buzzer sound when the incompatible options are tried to be activated in the programs. (For models with buzzer)

The program flow continues with the same step of the new program with the new parameters (temperature, times, liters). When new program is selected, display duration is changed according to same step of new program.

- In heating step: If temperature value of previous program is higher than the new programs temperature, cut off the heating step and go on with the next step of new program. If old temperature is lower than the new programs temperature, heat up water until it reaches to the desired temperature level of new program.
- In washing step: If the washing duration of previous program is higher than the new programs washing duration, cut off washing step and go on with next step of new program. If the old washing duration is lower than the new programs washing duration go on with washing step until it reaches to the desired temperature level of new program.
- In fill or fill+wash step: If the filled water liter of previous program is higher than the new program specified water liter value, cut off this step and go on with next step of new program. If the old water liter is lower than the new program water liter go on with this step until it reaches to the specified water liter value of new program.
- There is a special case in fill or fill+wash step, if old liter value is lower than new one: If the new program does not have the same step, and if there are washing / heating steps in the continuation of the same phase, the flow continues from the fill/fill+wash step of the previous phase of the new program.(for example, see picture 1)
- If a program is running on any phase and new selected program does not have the same phase of old program, flow goes on with next phase of the new program.

- If prewash program is selected while another program is running (except prewash phase), prewash program is started from beginning.

Step	Code	Option	C-X Basic Operations	PROGRAMS	
				Quick 30° 40°C	Eco 50°C
12			Wash		600"
13			Wash		↓
14		Prewash 2	Wash + Drain		Empty+20"
15			Fill	3.3 lt	3.3lt
16			Fill + Wash	4.4 lt	4.5lt
17			Wash		600"
18			Wash + Heating		↓
19		Wash		↓	
20		Main Wash	Wash + Drain	Empty+20"	↓
21			Fill	3.3 lt	↓
22			Fill + Wash	4.4 lt	↓
23			Wash + Detergent + Heating	60°	↓
24			Wash + Heating	Temp 1020°	60° Temp 1020°
25			Wash	60°	6000"
26			Wash + Heating	↓	↓
27			Pause	↓	↓
28			Wash	↓	↓
29			Wash	120° - TimePhase	1750° - TimePhase
30		P1	Wash+Drain	Empty+20"	↓
31			Fill	3.3 lt	↓

if filled water < 4lt

if filled water > 4lt

COMMANDS	Top Display	Front display	Flow ind. on Front display	End icon on Top Display	Start/Pause Led
Washing cycle is in progress	Duration of program	Duration of program	ON	OFF	OFF
Door open	Duration of program / Program number	None	OFF	OFF	ON
Select new program	Duration of new program / Program number	None	OFF	OFF	After pressing S/P -> Blink After pressing S/P again -> ON
Door closed after pressing Start/Pause(shorter than 4" for USA)	Duration of new program	Duration of new program	ON	OFF	OFF

MODIFICATION OF A PROGRAM DURING DELAY TIME

While delay timer is selected but not started or started and paused, if any program button is pressed, delay timer is cancelled and machine goes to ready state.

SWITCH OFF THE MACHINE DURING DELAY TIME

While delay timer is active, If machine switch off and on by ON/OFF button, delay timer is cancelled and machine goes to ready position.

If mains power off-on occurs (power cut); delay time resumes, does not start again.

POWER FAIL

During a Delay Start: At the power on, program consumes the remaining time.

During a Drain + Fill step: At the power on the program restarts the step to the beginning (with the drain).

During a Wash step: At the power on the program consumes the remaining time.

During a Heating step: At the power on the program continues heating up to the desired temperature. The time out for the heating restart to the beginning (water could be cold again).

During a Dry step: At the power on the program ends.

During the first step of a salt regeneration cycle: At the power on washing program will continue.

During the second step of a salt regeneration cycle: At the power on the program ends.

During the washing resin step at regeneration cycle: At the power on the program ends.

After a Power Fail washing program re-starts without any delay if temp. is less than 45° C.

After a Power Fail washing program **wait 8"** before re-starts program if temp. is equal or more than 45° C.

TURNING OFF/ON FROM ON/OFF BUTTON

During a Delay Start: At the power on, machine goes to ready state.

During a Drain + Fill step: At the power on the program restarts the step to the beginning (with the drain).

During a Wash step: At the power on the program consumes the remaining time.

During a Heating step: At the power on the program continues heating up to the desired temperature. The time out for the heating restart to the beginning (water could be cold again).

During a Dry step: At the power on and after the door is closed the program ends.

During the first step of a salt regeneration cycle: At the power on washing program will continue.

During the second step of a salt regeneration cycle: At the power on the program ends.

During the washing resin step at regeneration cycle: At the power on the program ends.

After a power off/on from on/off button, washing program re-starts without any delay if temp. is less than 45° C.

After a power off/on from on/off button, washing program **wait 8"** before re-starts program if temp. is equal or more than 45°C.

Component stoping or restarting behaviours in the interventions like power fail, turning on/off from on/off button, opening/closing door, flowchart requirements etc:

1)Dispanser activation in detergent step:

1.5 seconds after fill+wash step is passed, heater relay is on. 1 second after heater relay is on, circulation pump is activated. 3 seconds after circulation pump is activated, detergent dispanser is activated for 0.3

second.

2) Rinse aid activation in rinse aid step:

1.5 seconds after wash+heating step is passed, heater relay is on. 1 second after heater relay is on, circulation pump is activated. 3 seconds after circulation pump is activated, detergent dispenser(or rinse aid) is activated depends on the level.

3) At the end of wash+heat step or opening door in the wash+heat step:

Circulation pump stops firstly, then heater relay is off.

4) At the beginning of wash+heat step or closing door in the wash+heat step:

Heater relay is on firstly, then circulation pump works.

SOFTWARE REQUIREMENTS

HEATER

Heating relay must be switched with un-supplied Heater.

- Stop Circulation Pump.
- Wait for pressure switch certainly open.
- Open/Close Heater Relay
- Wait (Heater relay certainly close);
- Start Circulation Pump.

If Tablet is selected, heating steps must be $< 55^{\circ}\text{C}$ for steps before last rinse.

WATER FILL

Water Load is obtained by flow meter signals. When a fixed quantity of water is loaded, the reaching water level is checked by the activation of circulation pump. When the pressure is high enough, the pressure switch is activated.

For 1L water inlet, MCU must detect 210 Pulse/L (with +-5% tolerance) from flowmeter .

At the start program a drain 30" + empty is executed before fill.

When Inlet valve is ON, if there aren't flow meter impulses, failure routine of "absence of flow meter impulses routine" works (see on failure chapter).

If pressure sensing switch turns OFF during the wash, after a drain +20", another water load is executed (also see "return empty level" failure in failure chapter).

Water fill must work;

- Pressure > 0,8l: all OK
- 0,3<pressure<0,8l:OKwith time out
- Pressure< 0,3l: stop cycle.

Water fill is performed spray arms start.

WATER DRAIN

Water drain starts with drain pump ON for 33". After 30", circulation pump ON. When empty level is recognized (by pressure switch signal), the circulation pump stops and the machine continues for the request steps.

If pressure switch level doesn't switch in Empty level (during circulation pump on), failure of Water drain works (see 8.failure routines).

Water drain is performed with lower spray arm

Detergent dispenser step

After wash+heating step is started 3 seconds, Dispenser is activated during 5 seconds. If power fail or opening door or pushing Start/Stop or switching OFF is happened, Detergent dispenser step is started again.

Note: For the detergent step 2' of upper spray arm are performed.

Rinse aid dispenser step

Dispenser is activated 25 seconds during rinse aid dispenser step twice. There is 5 seconds between two activation. If power fail or opening door or pushing Start/Stop or switching OFF is happened, Dispenser is activated one more time 25 seconds

If the door is opened and re-closed during washing program, without a re-start program, detergent dispenser must return in Rinse aid distribution state.

Y2: for the rinse aid step 2' of upper spray arm is performed.

AUTOMATIC PROGRAM(TURBIDITY SENSOR)

Turbidity sensor is performed in the "auto delicate", "auto normal" and "auto intensive" programs.

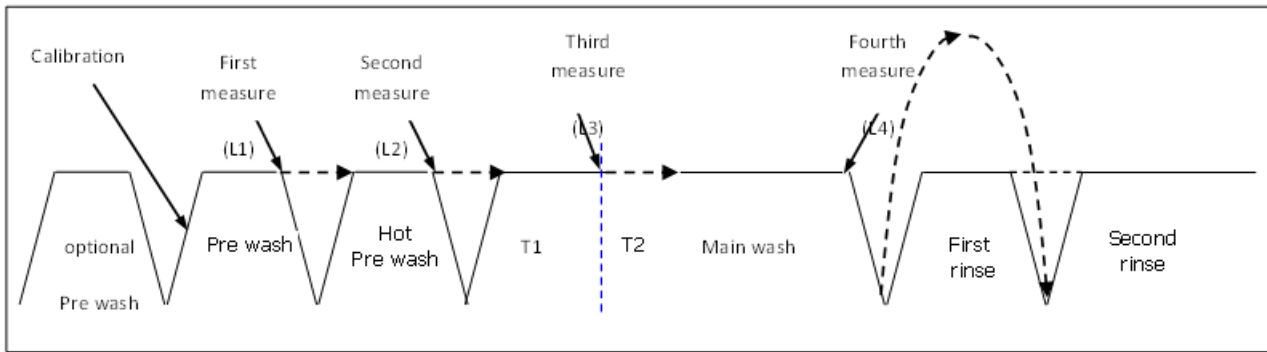

- 1) The calibration is executed after reaching P1 level in the first filling step.
- 2) The first measure is executed at the end of pre-wash.
 1. If turbidity is \leq TURBIDITY-LEVEL 1: drain is skipped.
 2. If turbidity is $>$ TURBIDITY-LEVEL 1: drain is skipped.
- 3) The second measure is executed at the end of hot pre-wash.
 3. If turbidity is \leq TURBIDITY-LEVEL 2: Drain is skipped.
 4. If turbidity is $>$ TURBIDITY-LEVEL 2: Drain is skipped.
- 3) The third measure is executed after the first heating step in the main wash.
 5. If turbidity is \leq TURBIDITY-LEVEL 3: The second heating step is skipped
 6. If turbidity is $>$ TURBIDITY-LEVEL 3: The second heating step is performed (T24_7 is performed)
- 4) The fourth measure is executed at the beginning of rinses.
 7. If turbidity is \leq TURBIDITY-LEVEL 4: First rinse is skipped.
 8. If turbidity is $>$ TURBIDITY-LEVEL 4: First rinse is executed.

The levels :

- TURBIDITY-LEVEL 1 = 3,0V
- TURBIDITY-LEVEL 2 = 3,4V
- TURBIDITY-LEVEL 3 = 3,7V
- TURBIDITY-LEVEL 4 = 3,8V

In case of break of turbidity sensor, the Automatic cycle is entirely executed. The fault is not reported.

ELECTRICAL COMPONENTS

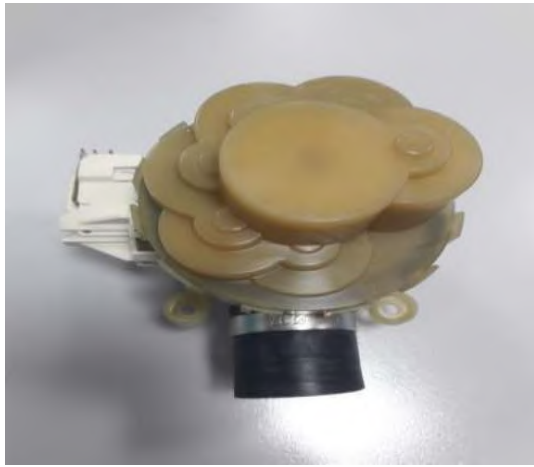

AQUAZONE

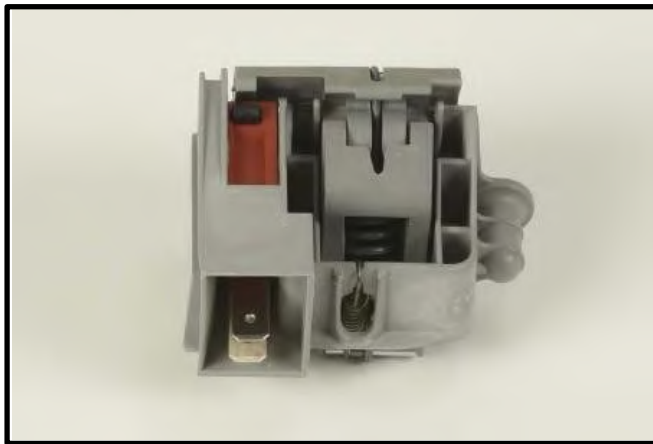

DOOR LOCK

It is a mechanical lock/release system that is closing the door, supplying the connection of electrical parts in the machine and cutting off the connection.

Currency 16 (4) A

CIRCULATION PUMP

Voltage	220/240
Frequency	50HZ
Total Power	90W
Coil Isolation Class	F
Thermal Protector	150°C
Pump Outlet Pressure	300mbar
Pump Flowrate	60 lt/min

Measurement of the primary windings of the washing pump. (118.2-135.9 Ω)

Measurement of the secondary windings of the washing pump (white cable – blue cable)(117.9-135.6 Ω)

Single direction, single phase, asynchronous and two pole.

It turns opposite clock direction.

It is assembled to the basement with rubber hangers.



FLOATER



CAPACITOR

2,5 μ F - 450 V class S2

Capacitor is permanently connected to the circulation pump coils.

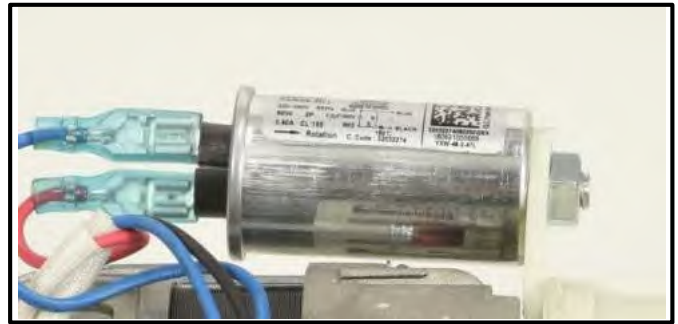

DRAINPUMP



Voltage	220/240 volt
Frequency	50Hz
Flowrate	30W
Coil Resistance / Hanyu	220 Ω % \pm 7
Coil Resistance / Leili	141 Ω % \pm 7
Coil Isolation Class	F
Thermal Protector	120 $^{\circ}$ C

HEATER

Voltage 220/240 volt
Total power 1800W

27.6-30.6ohm

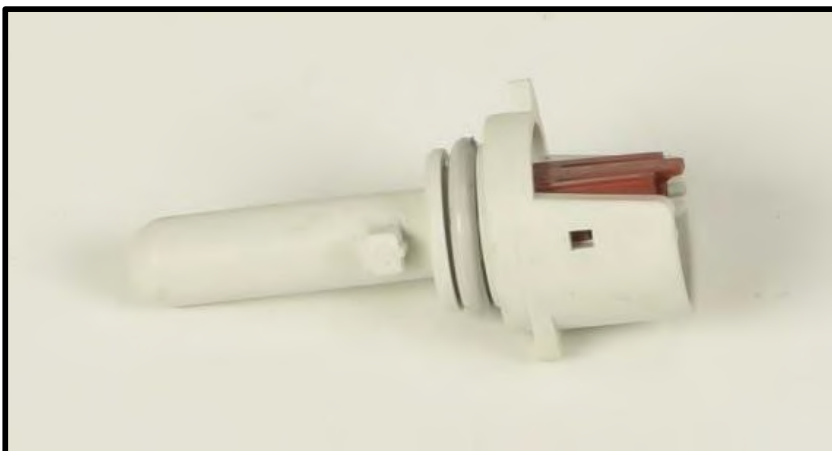
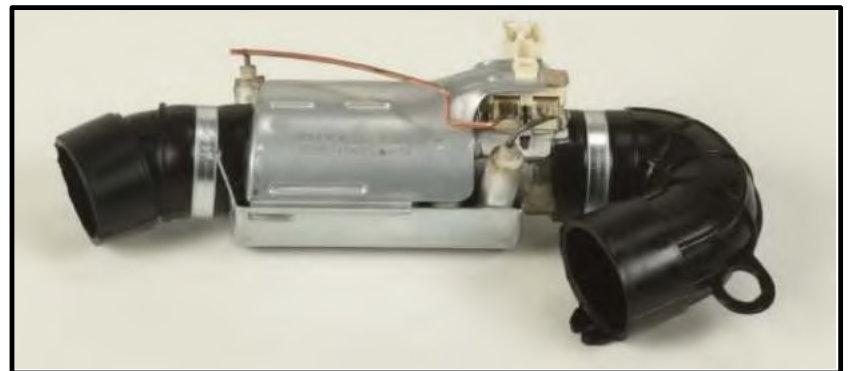

NTC

+25 $^{\circ}$ C	-	47.200	\pm	850 Ω
+30 $^{\circ}$ C	-	37.500	\pm	675 Ω
+40 $^{\circ}$ C	-	24.900	\pm	349 Ω
+50 $^{\circ}$ C	-	17.000	\pm	170 Ω
+60 $^{\circ}$ C	-	11.700	\pm	117 Ω
+70 $^{\circ}$ C	-	8.280	\pm	108 Ω
+80 $^{\circ}$ C	-	5.945	\pm	101 Ω

		C		T		
PRESSURE SWITCH	CN2.10 - CN2.2	0 Ω ∞Ω	KN2.9 - KN2.10	0 Ω ∞Ω	WATER NO WATER	

PRESSURE SWITCH

Voltage 220/240 v

Frequency 50/60 Hz

16 A - 3 Pins

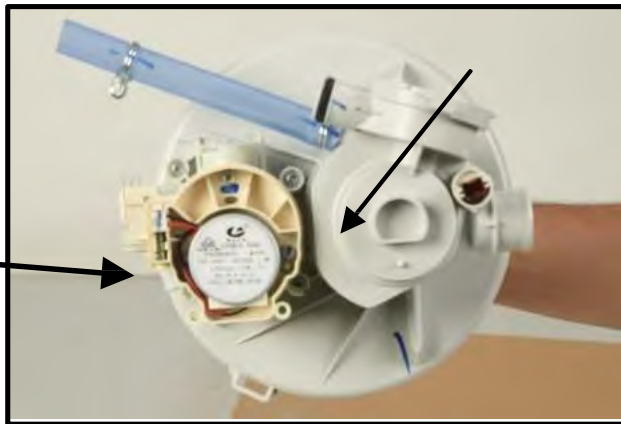
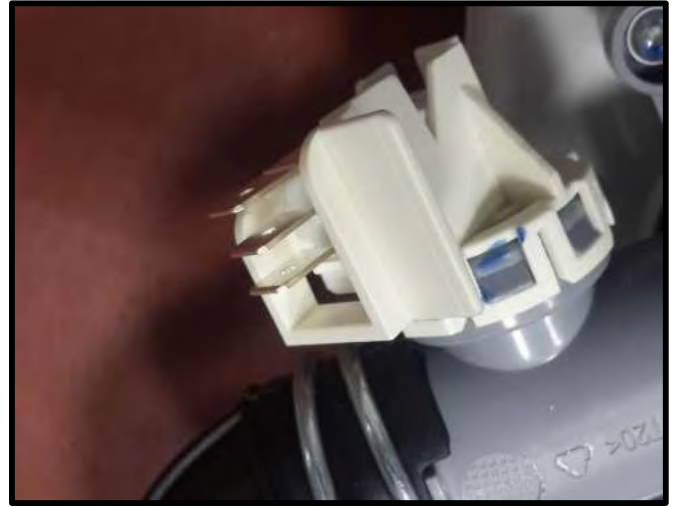

DIVERTER

There is diverter at A15 and A23 models It is assembled to the heater Casing Group.

Voltage	220/240 V
Frequency	50 Hz
Power	8W
Resistance	10500 ± %5 Ω

WATER INLET VALVE

Single inlet and single outlet standard single coil selenoid valve.

Voltage	220 - 240
Total Power	6W
Flowrate	2,5 ±% 15 lt/dk
Coil Isolation Class	H
Resistance	4200 ±%10

It is assembled to the basement and connect to the airbreak by hose.



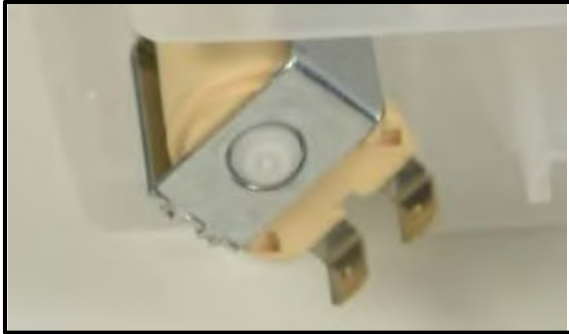
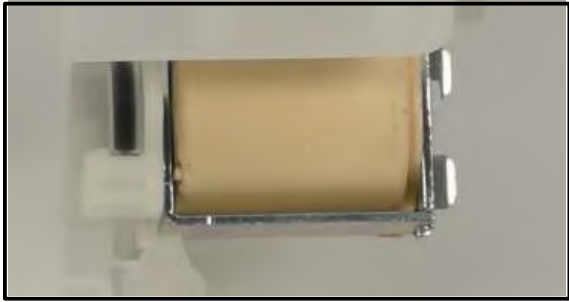

REGENERATION VALVE

Voltage	220/240 V
Frequency	50/60 Hz
Total power	6 W
Resistance	$3560 \pm \% 10 \Omega^{\circ}\text{C}$

Regeneration valve is assembled on the water softener.

PARASITE FILTER

Voltage	220/240
Frequency	50/60 Hz

$0,1 \mu\text{F (X1)} + 2 \times 2,2 \mu\text{F (Y2)} + 1\text{M}\Omega$

It is used to prevent parasites from the main supply It has been assembled to basement.

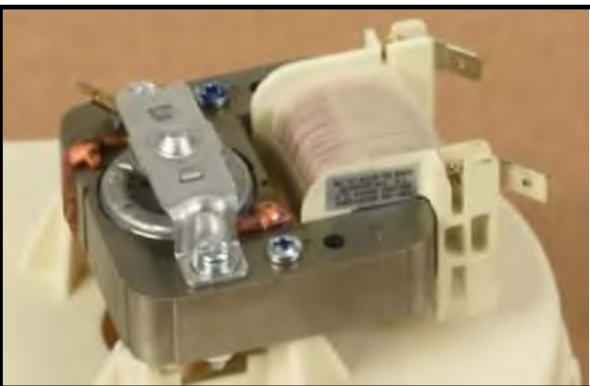
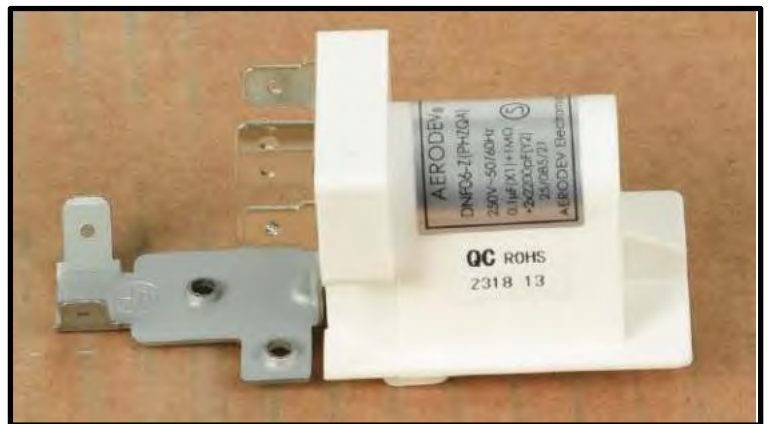

TURBO FAN MOTOR

There is a thermal protector shaded pole motor, two pole temperature is between $-40-150^{\circ}\text{C}$

There is turbo fan motor only at A models.

SALT SENSOR



Voltage 250 V
 Currency 50 mA

It is assembled to the water softener. It warns if the salt is less than requested quantity.

POWERCORD

Type	Electrical power cord
Material	PVC
Weight	0.15 kg
Length	1.5 m

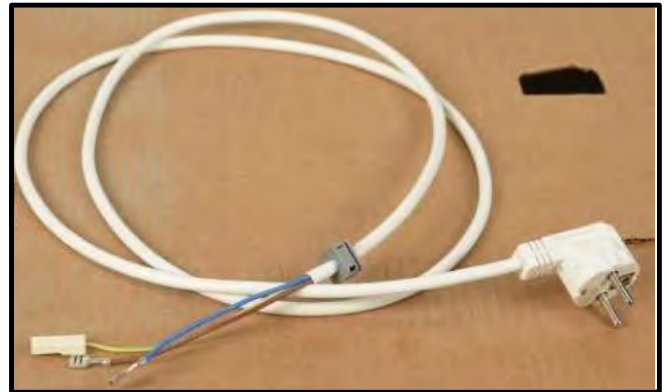

DRAIN HOSE



Drain hose maximum height	110 cm
Drain hose minimum height	50 cm
Drain hose maximum length	400 cm
Total Power	15 W
Voltage	220/240 V
Frequency	50 Hz
Resistance	238.6± %5 Ω

FAILURE CODES (Possible Problems)

F1 (ALARM IS ACTIVE FOR OVERFLOW)

FLOATER

- Floater switch can be out of order or have a problem with the cable connection.

TUB

- There can be a water leakage from the tub

ELECTRONIC CARD

- Electronic card can be out of order.

F2 (THE WASTE WATER IN THE MACHINE CANNOT BE DISCHARGED)

Drain hose

- Water outlet hose is clogged
- Check of the water outlet hose position.

Drain pump

- Check the drain pump resistance and power values
- There can be a problem with cable connection of the drain

Pressure switch

- Pressure switch of the heater casing group can have a mechanical or cable connection problem.

F3 (ERROR OF CONTINUOUS WATER INPUT)

Water inlet valve

- Water inlet valve can be out of order or can not be closed.

Electronic card

- Electronic card can be out of order.

F4 (FLOWMETER FAULTY)

Flowmeter

- Flowmeter can be out of order.
- Cable connection of flowmeter can be faulty.

Electronic card

- Electronic card can be out of order.

F5 (INADEQUATE WATER SUPPLY)

Water tap

- Make sure the water input tap is totally open and that there is no water cut.

Water inlet hose

- Close the water input tap, separate the water input hose from the tap and clean the filter at the connection end of the hose.

Water inlet valve

- Water inlet valve filter can be clogged.
- Water inlet valve can be out of order. There can be a problem with the cable connection of water inlet valve.

Floater

- Floater switch can be out of order or have a problem with the cable connection.

Pressure switch

- Pressure switch of the heater can have a mechanical or cable connection problem.

Circulation pump

- Circulation pump can be out of order or have a problem with the cable connection. External part can be blocked to the circulation pump.

F6 (NTC FAULTY)

Ntc

- Ntc can be out of order.
- Ntc cable connection can be faulty. Ntc can be short or open circuit.

Electronic card

- Check the power and resistance value of heater.
- Check the cable connection of the heater.
- There may be an explosion in the NTC triac region on the electronic card.
- The electronic card may be deformed.

CABLE HARNESS

- There may be a problem caused by the disconnection between the cable tree, NTC and electronic board.

NOTE: If the NTC part is faulty, it will not resist in any way.

F7 (EXTREME HEATING UP FAULTY)

Ntc

- If the water temperature inside machine higher than 77°C, ntc can be out of order.

Electronic card

- Electronic card can be out of order.

F8 (INADEQUATE HEAT)

Heater

- Check the power and resistance values.
- Check the cable connection of the heater.

Electronic card

- Check the electronic card

F9 (DIVERTER POSITION PROBLEM)

Diverter

- Check the values of the diverter.
- Check the cable connection of the diverter.

Electronic card

- Check the electronic card

FA (TURBIDITY SENSOR FAULTY)

Turbidity sensor

- There can be some soil around the turbidity sensor.
- Check the cable connection of the turbidity sensor.

Electronic card

- Check the electronic card.

COMPONENT VALUES MEASUREMENT

Precaution: Always remove the plug from the power socket before touching internal components.

WASHING PUMP:

From the electrical card:

You can only measure the primary winding value from the electrical card. Resistance value of the primary winding must be

	C	T	
CIRCULATIONPUMP	CN2.3- CN2.9	KN2.3- KN 2.8	Primarywinding Secondary winding (from the component)

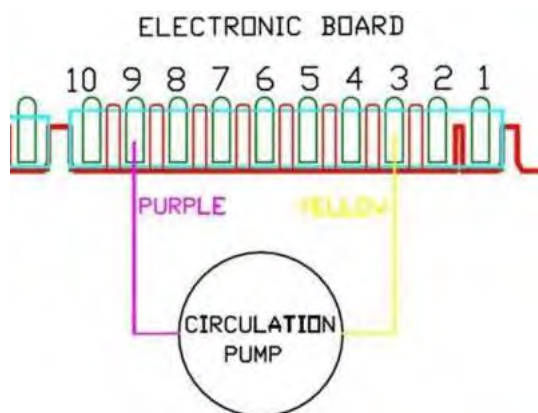

Above sketch show the connectors of the washing pump on the electrical card. Probes of the tester should be applied on to the related connectors.

From the component:



Measurement of the primary windings of the washing pump. (118.2-135.9 Ω)



Measurement of the secondary windings of the washing pump (white cable – blue cable) (117.9-135.6 Ω)

Probes of the tester should be applied on to the related connectors as shown on the pictures.

RINSE AID SENSOR

From the electrical card:

		C		T	
RINSEAIDSENSOR	CN 5.3- CN 5.2	0Ω NO RINSE AID ∞Ω THERE IS RINSE AID	KN50.8- KN50.9	0Ω NO RINSE AID ∞Ω THERE IS RINSE AID	Rinseaid off Rinseaid on

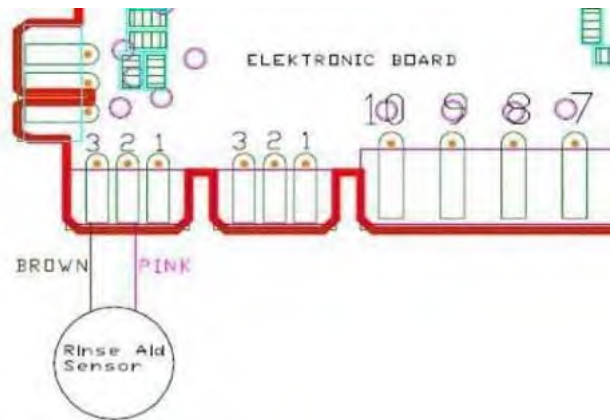

Above sketch shows the connectors of the rinse aid sensor on the electronic card.

From the component:

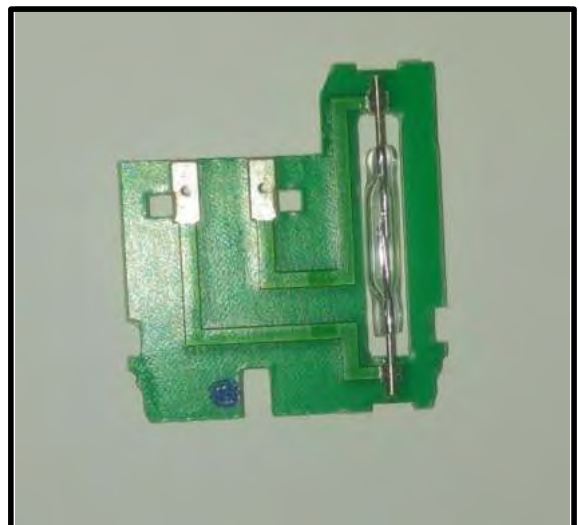
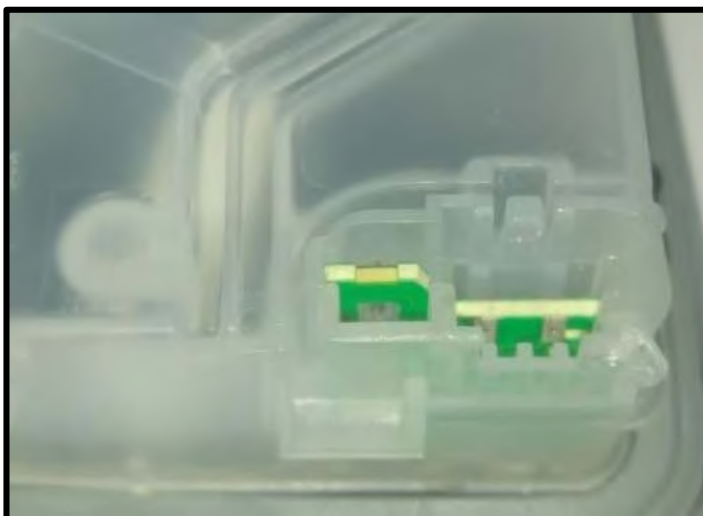

Probes of the tester should be applied on to the related connectors as shown on the pictures.

FAN MOTOR

From the electrical card:

	C	T
FAN MOTOR	CN 6.2 - CN 2.9	KN 6.2 - KN 2.8

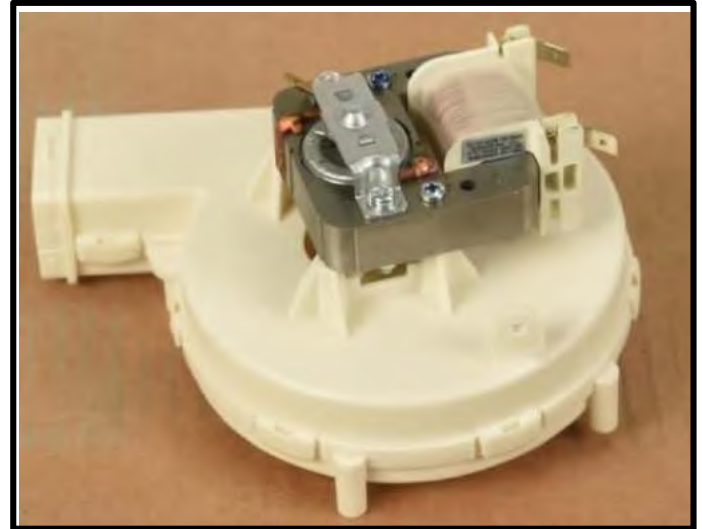
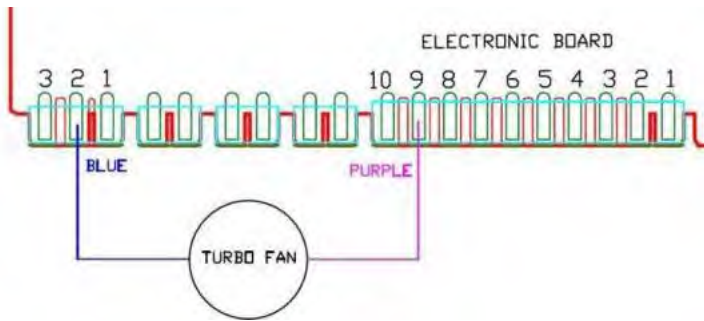

Above sketch shows the connectors of the fan motor on the electronic card.

From the component:



Turbo fan resistance value: $265 \pm 10\% \Omega$ (The resistance of the turbo fan is measured with the resistor switch).

DOOR SWITCH

From the electrical card:

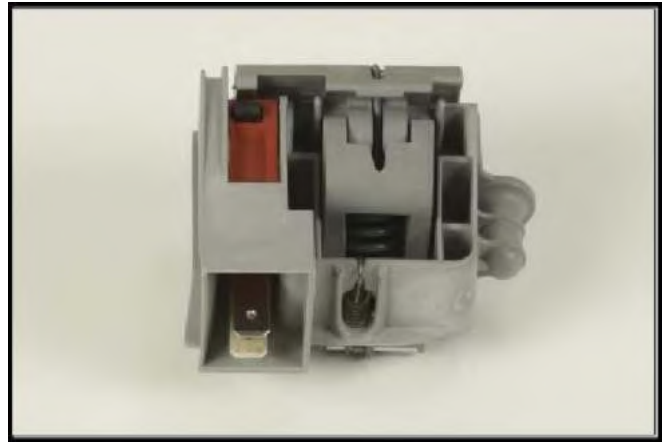
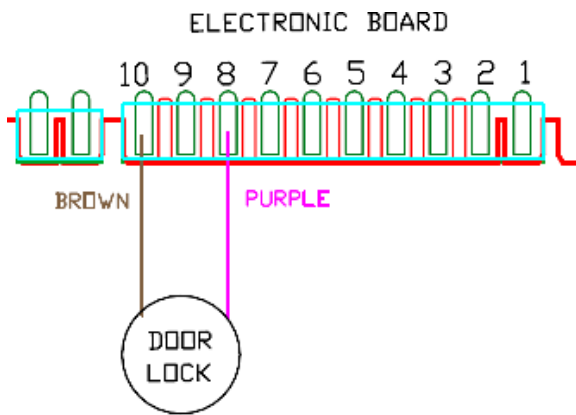

Above sketch show the connectors of the door switch on the electrical card.

From the component:

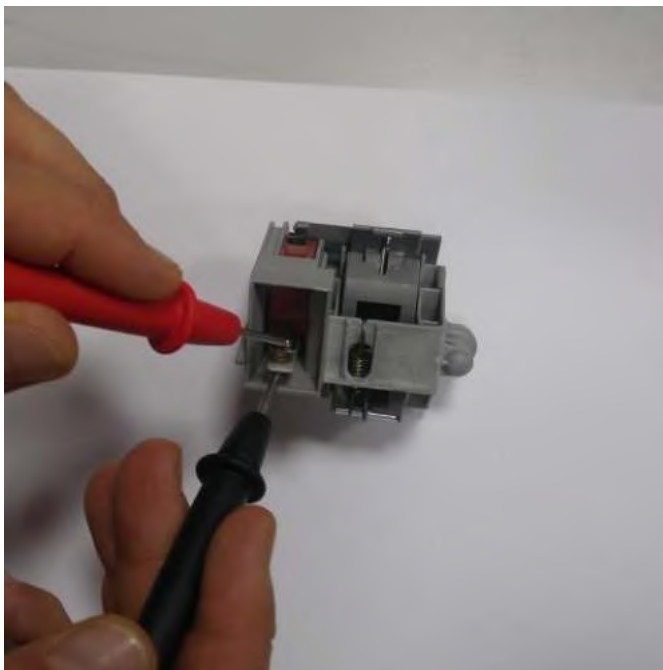

Probes of the tester should be applied on to the related connectors as shown on the pictures.

FLOATER

From the electrical card:

	C		T		
FLOATER(MICROSWITCH)	CN2.1- CN 2.5 CN2.1- CN 2.4	0Ω ∞Ω	KN2.5- KN 2.10 KN2.4- KN 2.5	0Ω ∞Ω	Microswitch is inactive (no water) microswitch is active (there is water)

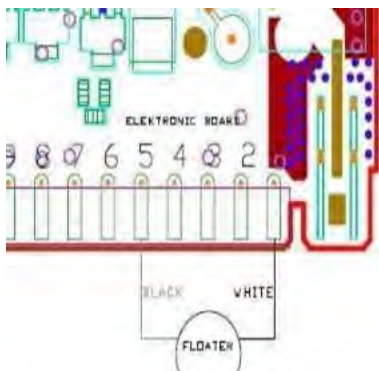
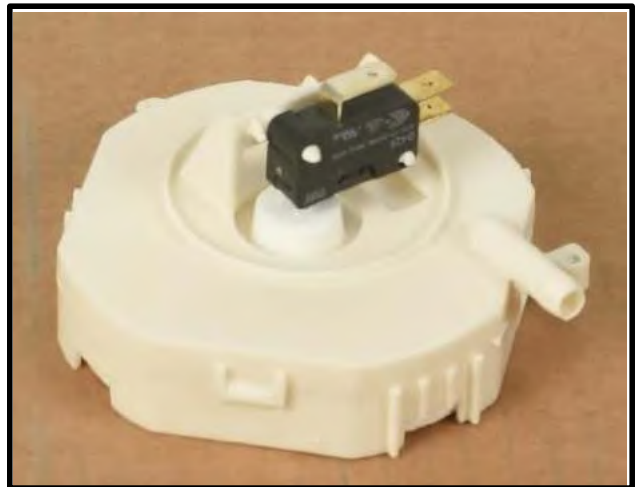

Position 1 : Yo can check the floater by controlling the specified value intervals.

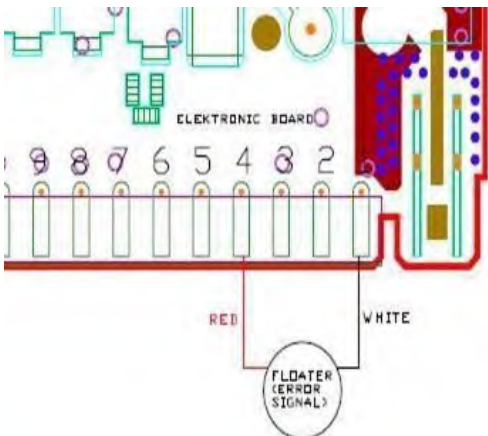

Position 2 : If failure code is occured related with the floater within control the above values: You can figure out whether leakage occurs or not.

SALT SENSOR

From the electrical card:

		C		T	
SALTSSENSOR	CN5.1- CN5.2	0Ω NO SALT ∞Ω THERE IS SALT	KN50.10- KN50.11	0Ω NOSALT ∞Ω THERE IS SALT	Measure just on the electronic

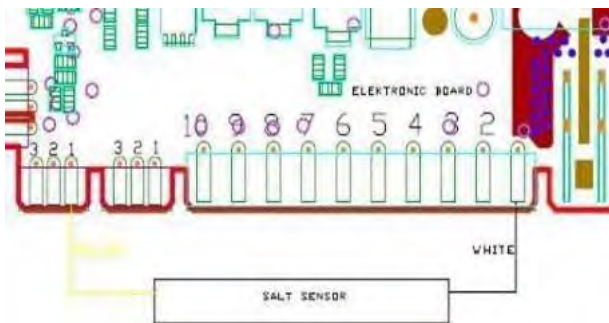

Sketch above show the connectors of the salt sensor on the electrical card. Probes of the tester should be applied on the related connectors.

From the component:



salt sensor can also be measured from the water softener when the salt sensor is assembled on the water softener.

Probes of the tester should be applied on to the related connectors as shown on the pictures.

DIVERTER

From the electrical Card:

	C	T
DIVERTER	CN 6.1 - CN 2.9 10500 ± %7 Ω	KN 6.1 - KN 2.8 10500 ± %7 Ω

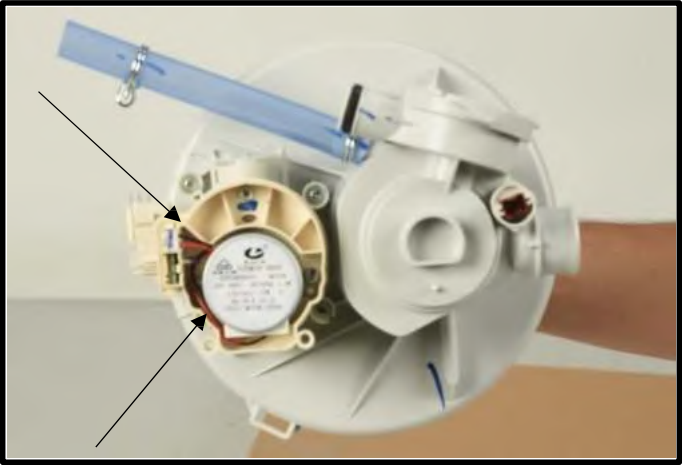
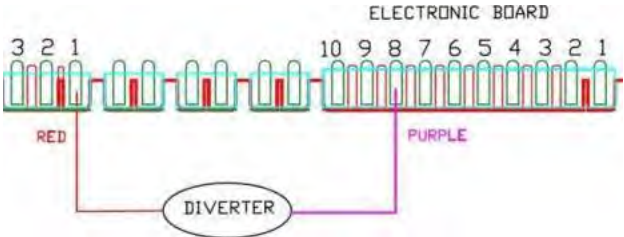

Sketch above show the connectors of the diverter on the electrical card. Probes of the tester should be applied on to the related connectors.

From the component:

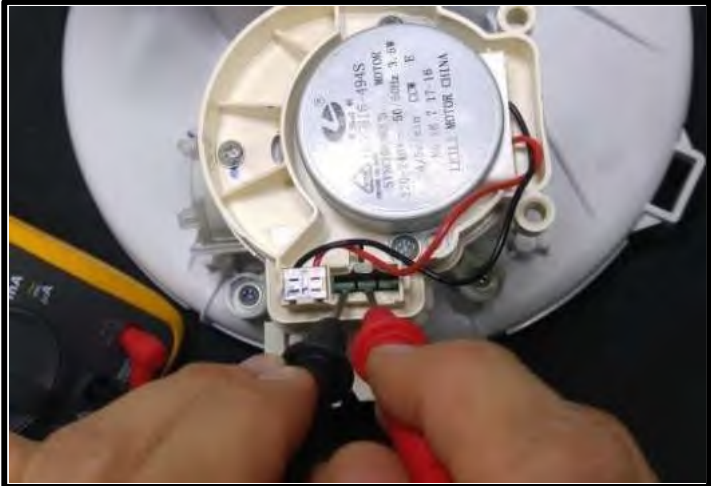

Probes of the tester should be applied on to the related connectors as shown on the pictures.

PRESSURESWITCH

From the electrical card:

	C		T		
PRESSURE SWITCH	CN2.10-CN2.2	0Ω ∞Ω	KN2.9-KN2.10	0Ω ∞Ω	Full fill water nowater

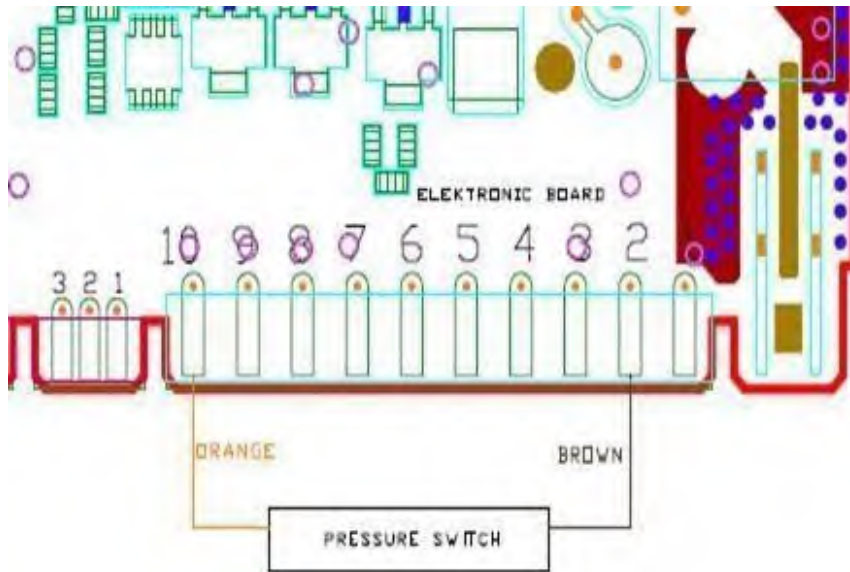

From the component:



Probes of the tester should be applied on to the related connectors as shown in the picture above.

REGENERATION VALVE

From the electronic Card:

	C	T
REGENERATION VALVE	CN2.2- CN2.7 3560 $\Omega \pm \%10(25^{\circ}\text{C})$	KN2.2- KN2.10 3560 $\Omega \pm \%10(25^{\circ}\text{C})$

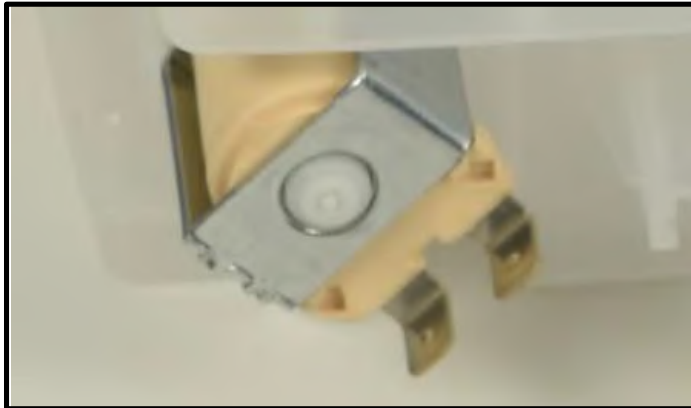
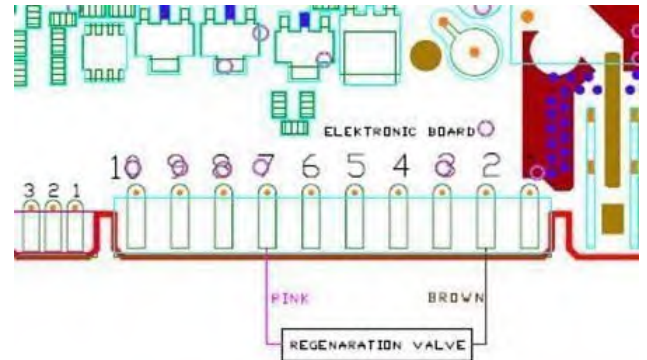
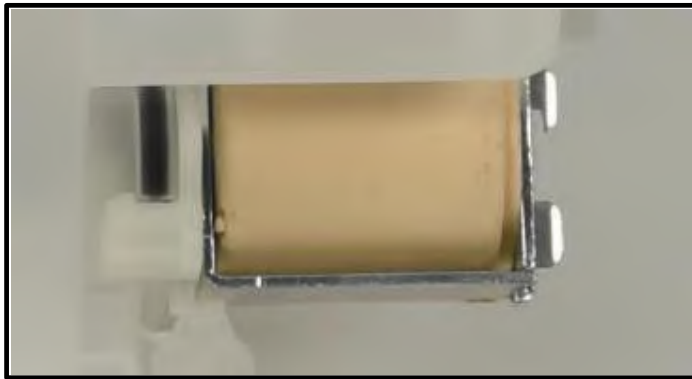

Above sketch show the connectors of the regeneration valve on the electronic card. Probes of the tester should be applied on to the related connectors.

From the component:



HEATER

It can't be measured from the electrical card.

From the component:

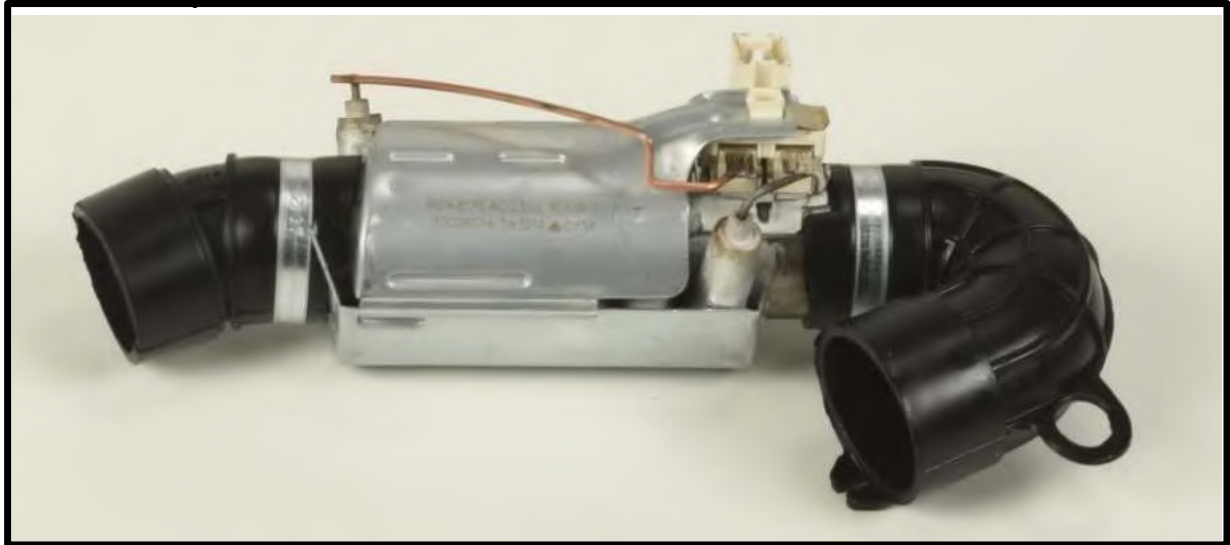

DETERGENT DISPENSER

It can't be measured from the electrical card:

	C	T
DETERGENT DISPENSER	2300 Ω \pm %10 (25 C°)	2300 Ω \pm %10 (25 C°)

From the component:

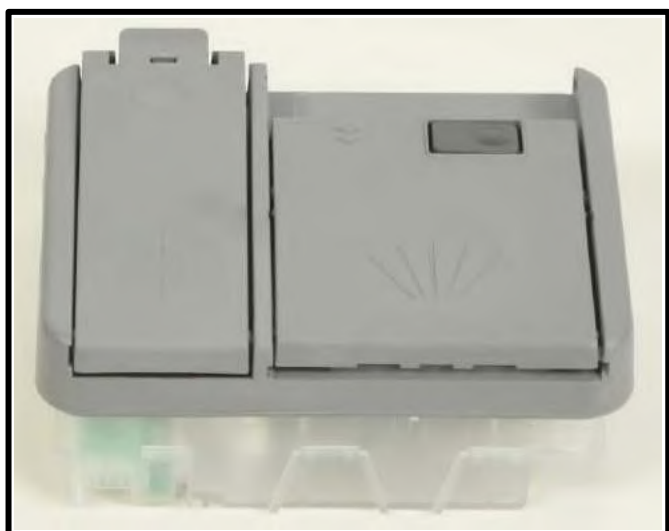

WATER INLET VALVE

From the electrical Card:

	C	T
WATER INLET VALVE	CN2.6- CN2.9 4200 Ω ± %10 (20°C)	KN2.6- KN2.8 4200 Ω ± %10 (20°C)

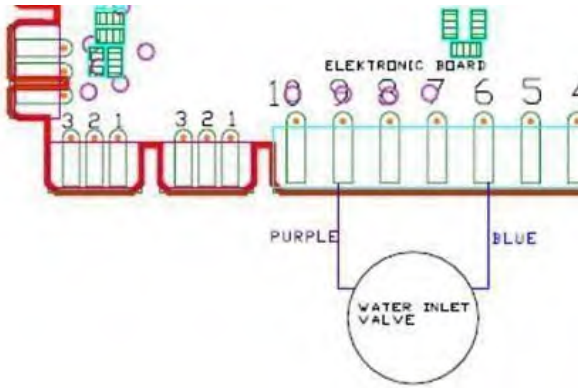

Above sketch show the connectors of the water inlet valve on the electrical card. Probes of the tester should be applied on to the related connectors.

From the component:



Probes of the tester should be applied on to the related connectors as shown on the pictures.

DRAIN PUMP

From the electronical Card:

	C	T
DRAIN PUMP / HANYU	CN2.2 - CN2.4 220 Ω % ±10	KN2.4 - KN2.
DRAIN PUMP / LEILI	CN2.2 - CN2.4 141 Ω % ±10	KN2.4 - KN2.

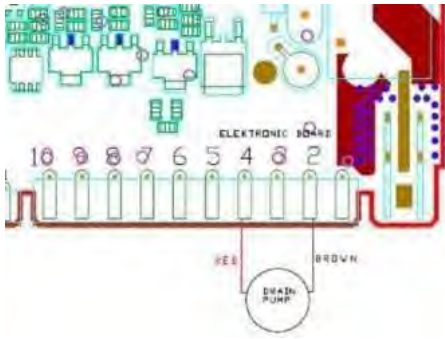

Above sketch show the connectors of the drain pump on the electronic card. Probes of the tester should be applied on to the related connectors.

From the component:



Probes of the tester should be applied on the related connectors as shown on the pictures.

DISASSEMBLY

CAUTION!: REMOVE ELECTRIC PLUG FROM THE SOCKET DURING THE DISASSEMBLY

Top Plate

- a) Remove two screws that fix the top plate at the back.
- b) Push the top-plate back and pull it up.



Plastic Kick Plate

- a) Remove two screws fixing plastic kick plate.



- b) Remove the plastic kick plate as it is shown in the picture.



INTERNAL FEEDING TUBES AND SPRAY ARMS REMOVAL

1) Unscrew the feed channel tabs with the help of a screwdriver

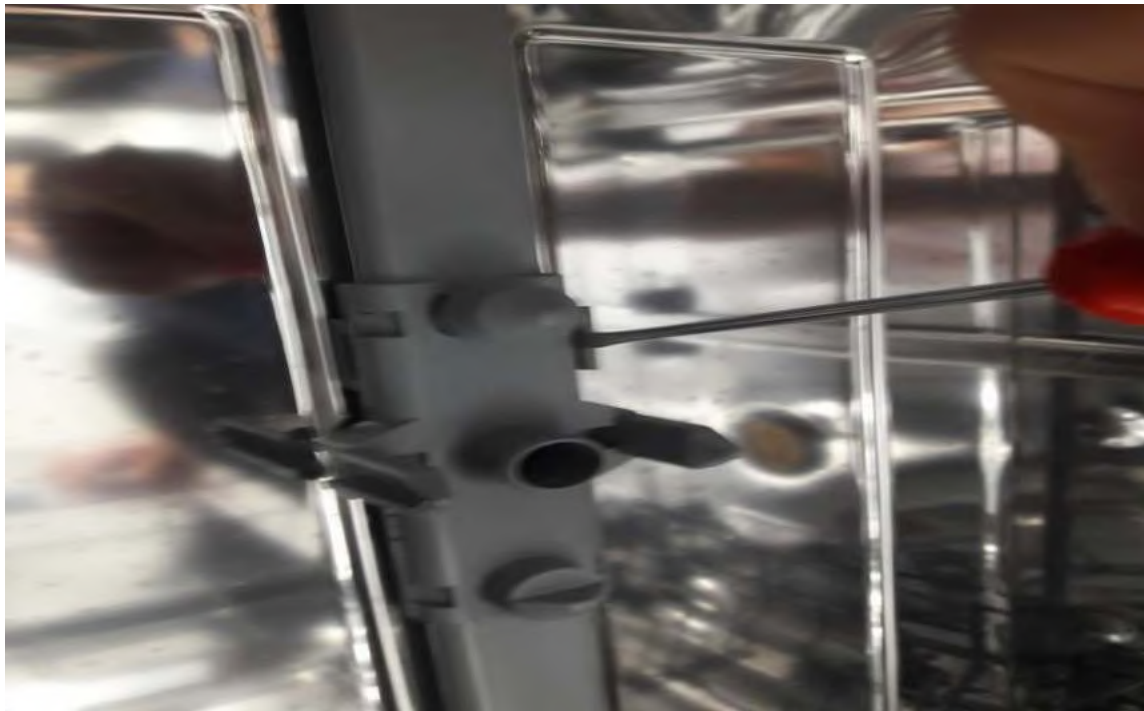

2) To assemble, manually narrow the feed channel replacement and insert it into the tabs

3) Pull out the top spray channel by turning it clockwise

4) Turn it counterclockwise to reinstall it

5) To remove the lower spray arm, kindly pull it up



The components that are inside the tub course, micro and metal filters

- a) Open the door.
- b) Remove lower basket
- c) To remove microfilter group rotate them in the direction of counter clockwise and pull them up as it is shown in the picture



- d) To remove microfilter group (course filter and micro filter) pull them as it is shown in the picture.



- e) To remove the metal filter pull it up as it is shown in the picture.



Draining hose



- a) Remove the hose connection plastic.
- b) Remove lower cover.
- c) Remove the clamp that fixes draining hose to the sump
- d) Remove draining hose

Lower basket



- a) Open machine's door.
- b) Pull the basket to yourself.

Upper basket



- a) Open upper basket rail lock front.
- b) Pull the basket to yourself and remove it.



Water Inlet valve

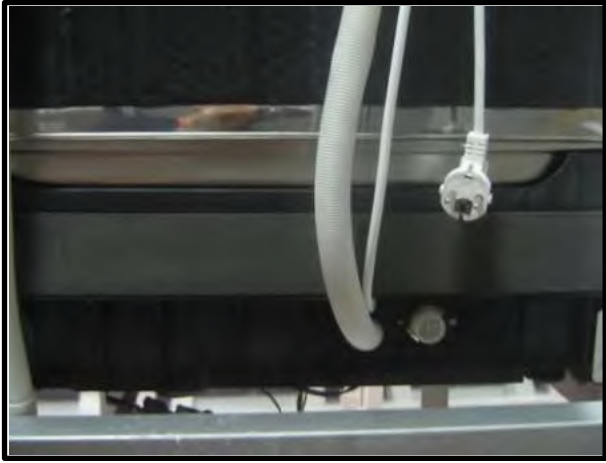

a) Remove lower cover.



b) Remove the wire that is connected to the water inlet valve.

c) Remove the clamp that connects water inlet valve and air-break as it is shown in the picture

To remove water inlet valve pull it back as it is shown in the direction of picture then release water inlet valve from the pins that is connecte to and rotate it in the direction of counterclockwise.



TURBO FAN REMOVAL INSTRUCTIONS

1) Remove top tray



3) Disconnect the condensate unit from the turbo fan.



2) Remove the side panel rear and front screws



side panel rear screw

4) Remove the turbo fan screws



turbo fan screws

5) Disconnect turbo fan cables

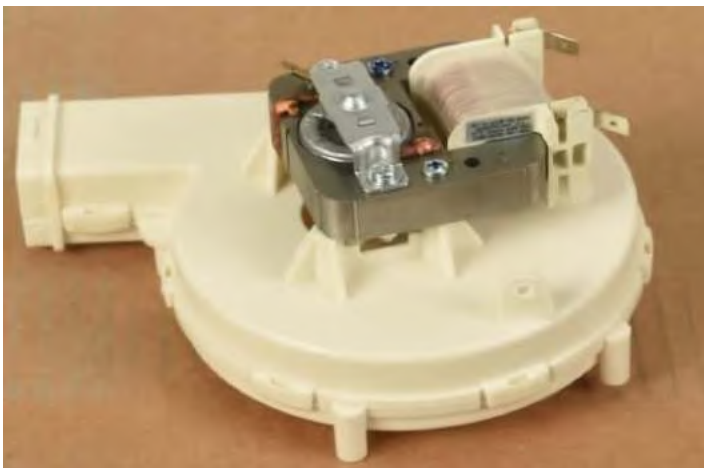

6) Remove the turbo fan from its replacement + to reassemble,
Before connect the cables,
Install the screws,
install the condensate unit

5) Disconnect ntc cables

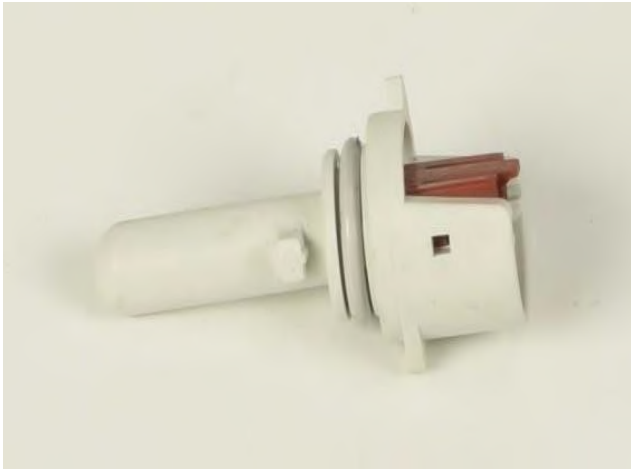

NTC

6) Disconnect heater hose

7) Unscrew eco or diverter part(it is changeable) screws

8) Then get the sump



To assemble, connect the cables and screws in same way.

SUMP GROUP REMOVAL INSTRUCTIONS

1) Remove 2 screws on top



sump screws

2) Remove the drain pump



drain pump

3) Remove the drain hose



drain hose

4) Remove the blue hose from the water softener to the pool group



blue hose

HEATER REMOVAL INSTRUCTIONS

1) Remove 2 clamps



2) Disconnect cable connections and get the heater

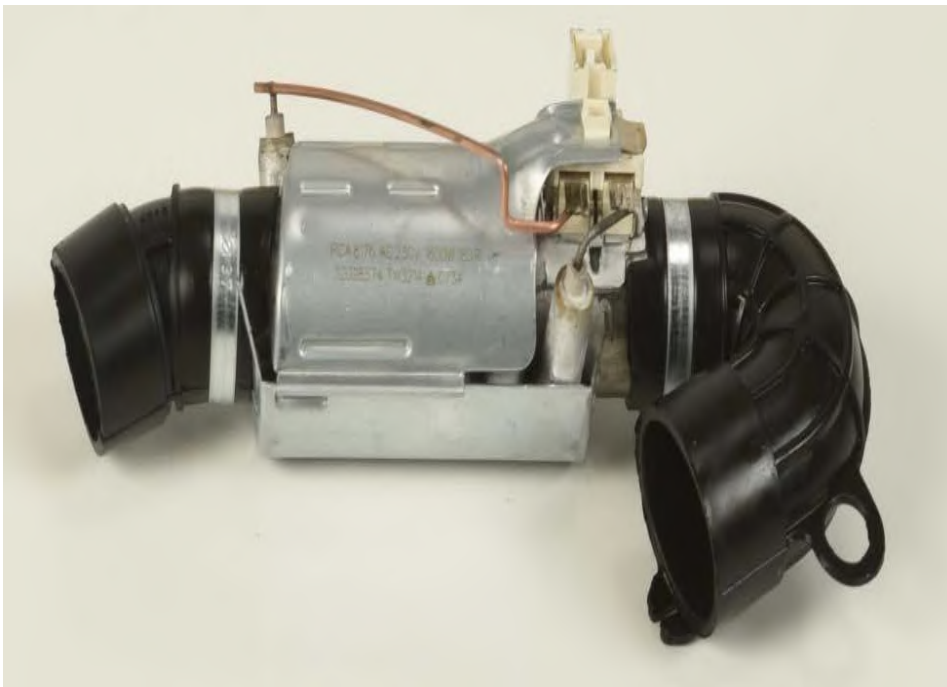

3) To assemble, the cables are connected first and the screws are attached.

Floater

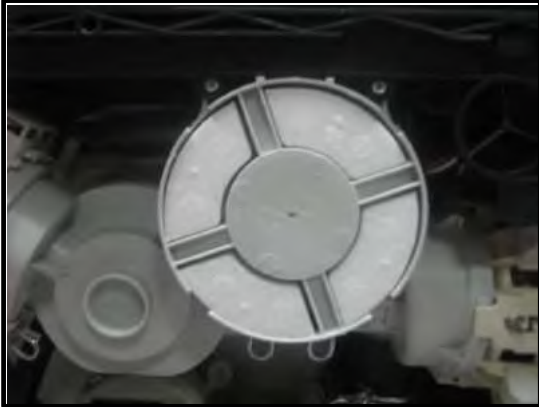

a) Remove lower cover.



b) Remove two screws that fix floater as it is shown in the picture.



c) Remove the two floater hoses.

d) Remove the wire that is connected to the floater.

Water softener



a) To remove salt cup cover, rotate it in the direction of counterclockwise

b) To remove salt cup nut, rotate it in the direction of counterclockwise.

c) Remove left side panel.

d) Derach the connections which are between water softener and air-break.

e) Remove lower cover.

f) Remove the hose that is between sump and salt camp.



Parasite filter



a) Remove lower cover.

b) Remove one screw fixing parasite filter.

c) Remove wires.

d) Push parasite filter and remove it.

DIVERTER REMOVAL INSTRUCTIONS

1) Disconnect the diverter cables



diverter cables

2) Disconnect pressure switch cables



pressure switch

3) Disconnect turbidity sensor cables(if the machine has)

4) Unscrew the diverter screws

5) Pull the clamps with pliers (**Diverter clamp is next to the circulation pump's clamp. you can see in the circulation pump removal instruction page).**

Access the components from the lower cover

a) Lay the appliance on the rear panel.



b) Remove lower cover from the places that are shown in the picture.

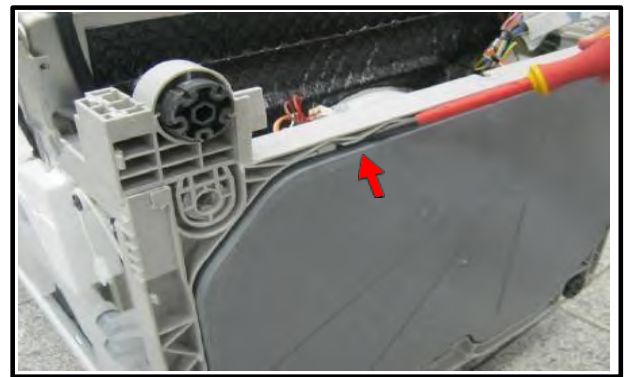

CIRCULATION PUMP REMOVAL INSTRUCTIONS

1) There are 2 clamps.

3) remove the straps from both sides

2) Push the 2 clamps upwards.



pushing the clamps upwards

To access the components from in Front of the Machine



- a) Remove plastic kick plate iron sheet and basement front cover

Regeneration valve

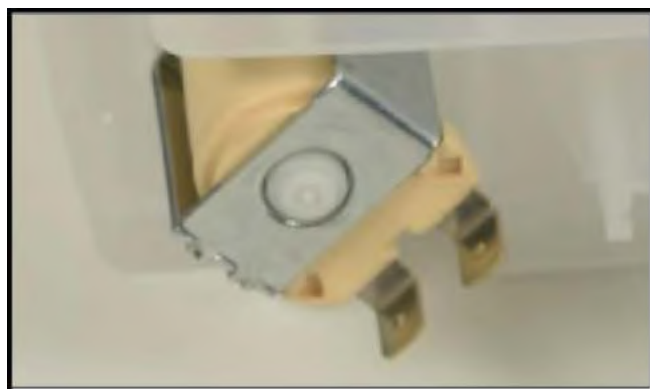

- a) Remove plastic kick plate and kick plate iron sheet.
- b) Remove the wires
- c) To remove regeneration Value rotate counterclockwise and pull it as it is shown in the picture.

Drain pump



- a) Remove plastic kick plate and kick plate iron sheet
- b) Remove the wires.
- c) To remove the drain pump that fixes to the sump, rotate it in the direction of counterclockwise and pull.

Power cord

- a) Remove hose connection plastic.



- b) Remove the lower cover.
- c) Remove the wires that is between power cord and parasite filter.
- d) Remove the power cord.



Hose connection plastic



a) Remove left side panel.



b) By using flat tip screwdriver remove hose connection plastic's hinge from the basement as it shown in the picture



c) Push the hose connection plastic.

Warning: If you do not obey instrucyions while disassembly od the hose connection plastic it can be broken.

Air - break



a) Remove the left side panel of the machine.

b) Open machine's door

c) Rotate counterclockwise air-break nut and remove it.

d) Remove air-break's connections with salt cap as it is shown in the picture. (be careful about plastic hinges)



Door Inside

- a) Remove side panels.
- b) Remove Hinge Spring.



Door spring

- c) Pull the door inside up as It is shown in the picture.
- d) Remove two screws that fix hinge movement sheet iron to the door inside.



KNOB REMOVAL INSTRUCTIONS



- 1) Remove control panel,
- 2) Remove the pcb box,
- 3) Remove the plastic tabs around the knob by flexing them.

DISPANSER REMOVAL INSTRUCTIONS

1) Remove front panel

2) Disconnect the dispenser cable harness



Dispanser cables

4) Then the dispenser will drop in



dispanser is free

3) Remove the metal tabs on the top, bottom and sides to disengage the dispenser.



metal tabs on the top

5) To assemble, tighten the metal tabs with a pliers

6)

After applying silicone oil or liquid soap to dispenser, press down and engage dispenser.



pressing to the dispanser down

DOOR LOCK REMOVAL INSTRUCTIONS

1) Remove control panel screws

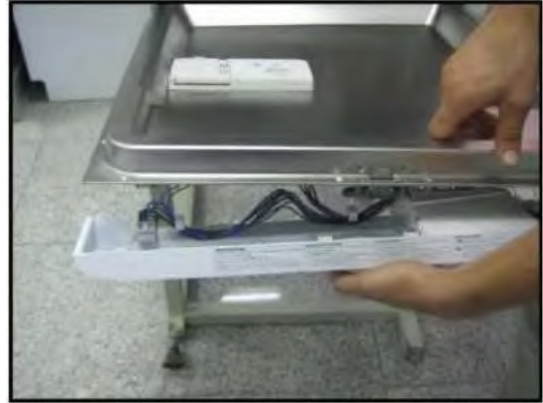

2) Disconnect cable connections with door lock



3) Remove two door lock screws



ELECTRONIC CARD REMOVAL INSTRUCTIONS

1) Remove top tray



3) Remove side panel



3) Remove side panel support styrofoam

4) Pull up the pcb box



5) Disconnect cable connections from cable harness

6) Remove the tabs and take the electronic card

7) To assemble, reinsert the pcb box into the tabs.

Control Panel

- a) Remove 6 screws that fix control panel to the door inside sheet iron.
- b) Remove the control panel group carefully as shown in the picture

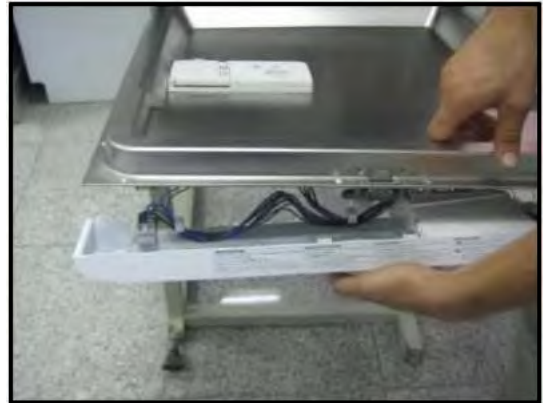

- c) Remove the cable connection plastic which fix cable harness to the control panel as shown in the picture.
- d) Remove the wires that are connected to control panel group.



Control Panel

- a) Remove 6 screws that fix control panel to the door inside sheet iron.
- b) Remove the control panel group carefully as shown in the picture

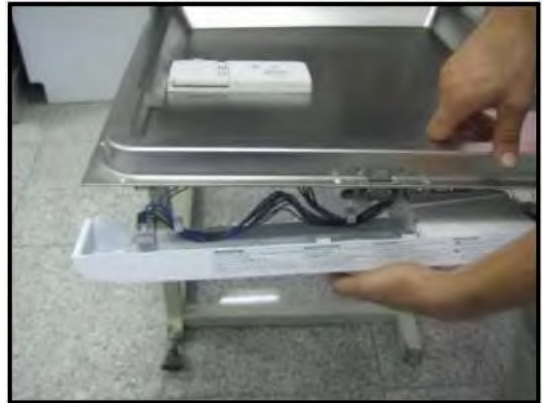

- c) Remove the cable connection plastic which fix cable harness to the control panel as shown in the picture.
- d) Remove the wires that are connected to control panel group.



Kick Plate Sheet Iron

- a) Remove top plate, plastic kick plate and side panels.
- b) Remove the screws (4 screws) that fix the kick plate sheet iron.
- c) Pull it down as shown in the picture.



- To remove the side panel, remove the upper plastic hinge and than the above one and pull it up.



Front Panel

a) Remove the screws as it shown in the picture.



b) Pull down the front panel after removing the screws.

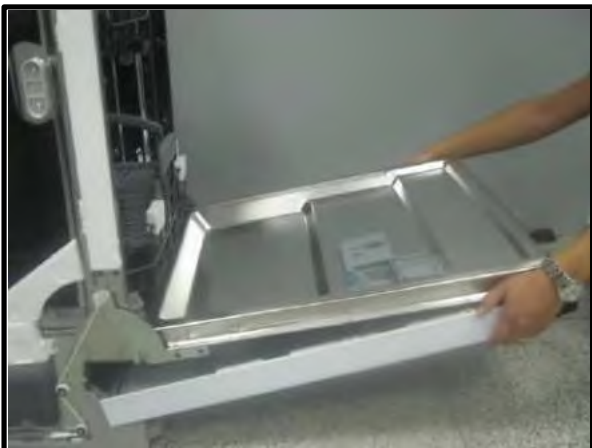

Side panels removal instructions

1) Remove top table screws



Top Tray screws

2) Remove the side panel rear screws



Side panel rear screws

3) Remove the kick plate plastic after removing the front panel



Plastic kick plate screw

4) Remove the side panel front screws



5) remove the side panel rear tabs



6) Remove the side panel front tabs



INNER LIGHT SOURCE REMOVAL INSTRUCTIONS

1) Remove top tray



2) Remove side panel



3) Remove side panel support styrofoam

4) Remove the cables



Note: This visual is representative sample

5) Rotate counterclockwise nut and remove it.



Note: This visual is representative sample.



OKAM MATTERS TO BE CONSIDERED IN ASSEMBLY OF THE MECHANISM ASSEMBLY

1_ OKAM In order to assemble and disassemble the mechanism, the top plate and the two right-left side panels must be removed.

2_ OKAM mechanism 220V supply cable assembly and route must be appropriate.

In models with water recovery tank;

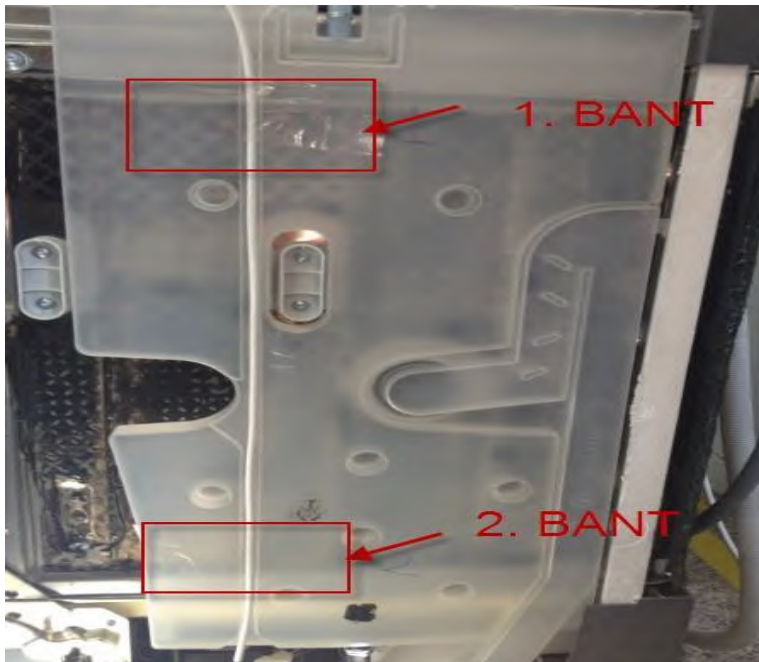

3 _ For Machines Without Water Tank:

OKAM cable will be lowered by leaning to the right of the rear rail bracket on machines with door opening feature and without water tank. The banding will be at the 2 points shown below.

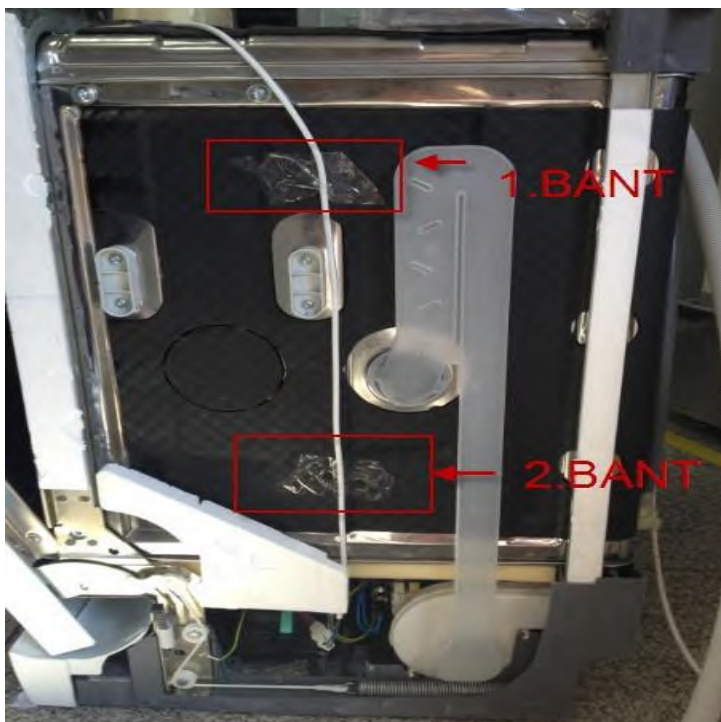

4_ OKAM The spring assembly should be screwed onto the fixed hinge and the movable hinge spring should press on the mechanism centrally, there should be no deformation in the springs.

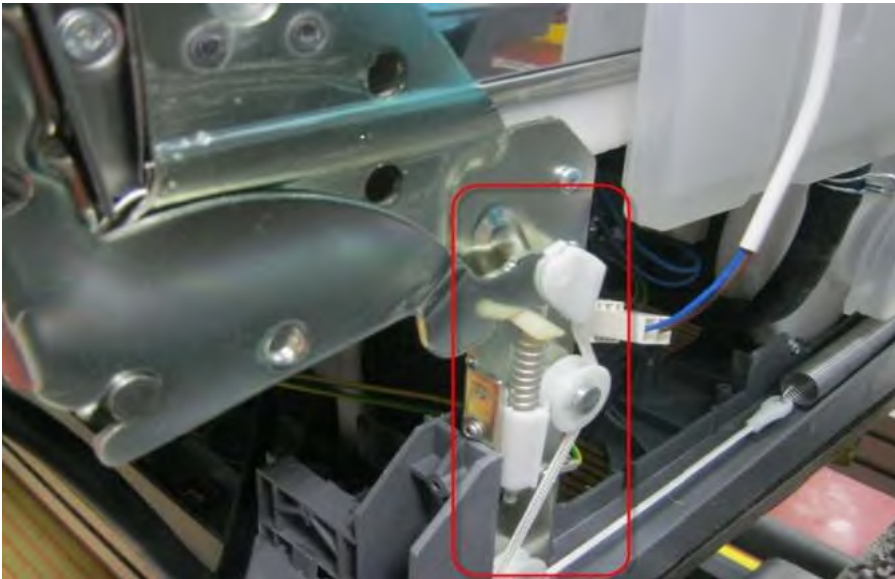

5_ OKAM In the machines with the drying mechanism, the mechanism crank should open the door by pushing the door outwards at the end of the drying step, then the shaft should be slowly pulled inward after cooling within 30 seconds.

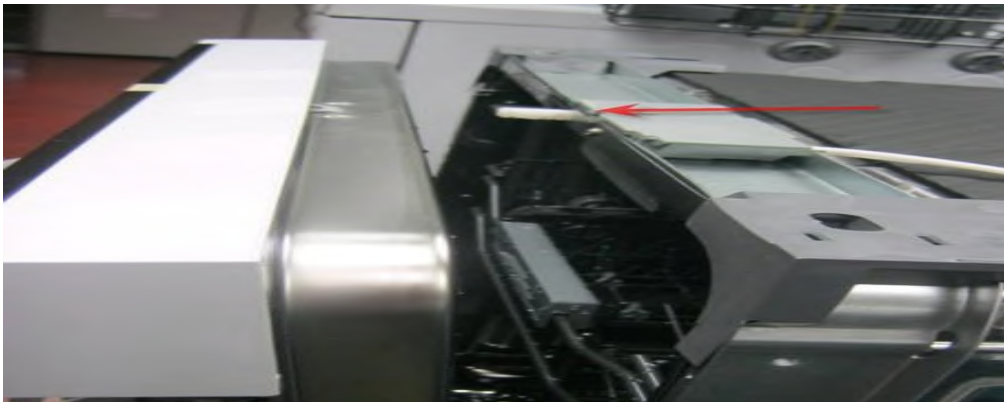

6_ OKAM assembly socket assembly must be appropriate and ensure that it is fully seated.

