

Platine affichage facultative selon modèle

CONTROL MAIN BOARD

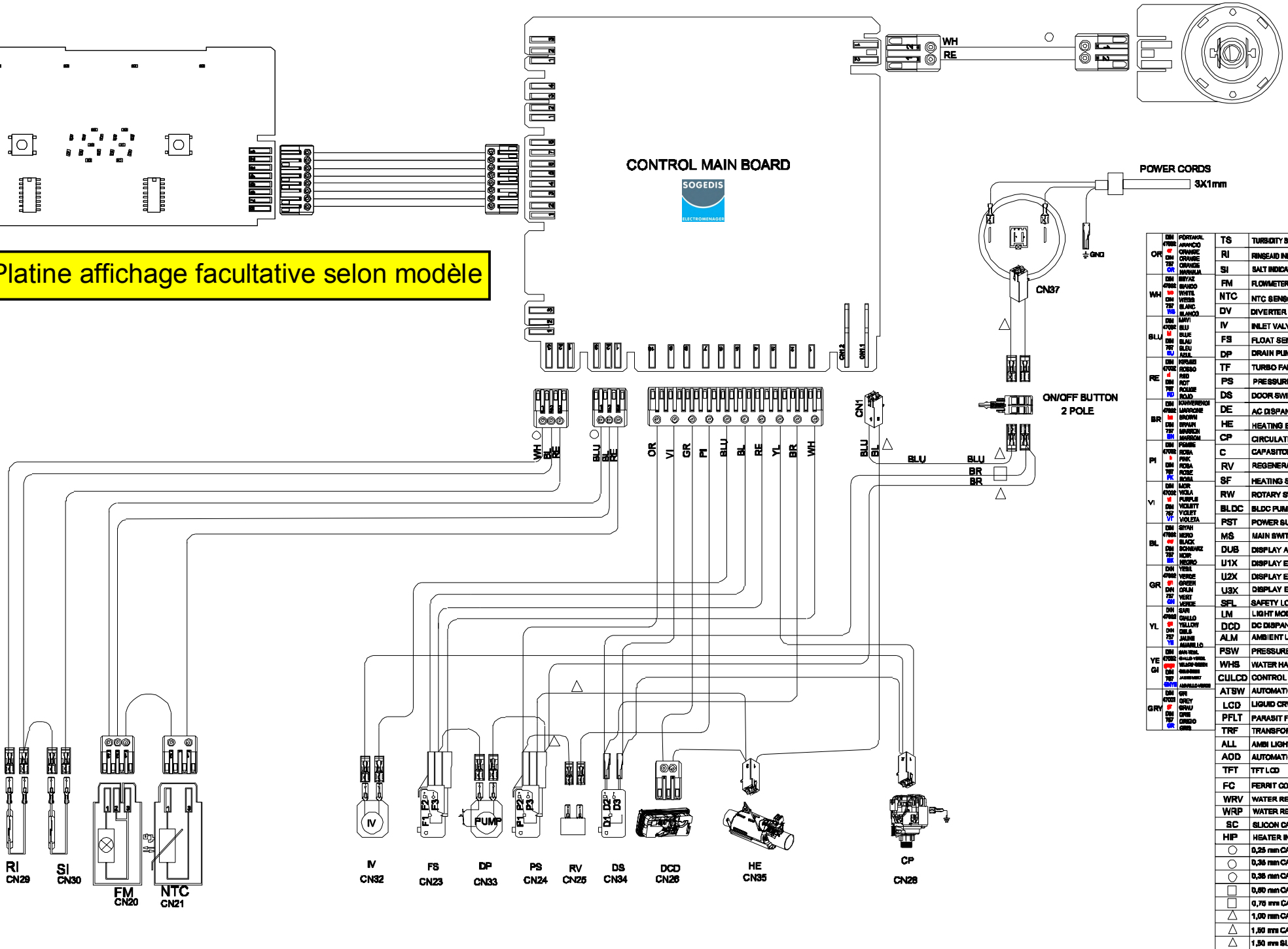

OR	PORTAL	TS	TURBIDITY SENSOR
OR	ORANGE	RI	RINSE/INDICATOR
OR	ORANGE	SI	SALT INDICATOR
OR	ORANGE	FM	FLOW METER
WH	WHITE	NTC	NTC SENSOR
WH	WHITE	DV	DIVERTER
WH	WHITE	IV	INLET VALVE
BLU	BLUE	FS	FLOAT SENSOR
BLU	BLUE	DP	DRAIN PUMP
BLU	BLUE	TF	TURBO FAN
RE	RED	PS	PRESSURE SWITCH
RE	RED	DS	DOOR SWITCH
BR	BROWN	DE	AC DISPENSER
BR	BROWN	HE	HEATING ELEMENT
BR	BROWN	CP	CIRCULATION PUMP
PI	PINK	C	CAPACITOR
PI	PINK	RV	REGENERATION VALVE
PI	PINK	SF	HEATING SAFETY
VI	VIOLET	RW	ROTARY SWITCH
VI	VIOLET	BLDC	BLDC PUMP
VI	VIOLET	PST	POWER SUPPLY TERMINAL
BL	BLACK	MS	MAIN SWITCH
BL	BLACK	DUB	DISPLAY AND USER BOARD
BL	BLACK	U1X	DISPLAY END USER BOARD
GR	GREEN	U2X	DISPLAY END USER BOARD
GR	GREEN	U3X	DISPLAY END USER BOARD
GR	GREEN	SFL	SAFETY LOCK
YL	YELLOW	LM	LIGHT MODULE
YL	YELLOW	DCD	DC DISPENSER
YL	YELLOW	ALM	AMBIENT LIGHT MODULE
YL	YELLOW	PSW	PRESSURE LEVEL SWITCH
YE	YELLOW	WHS	WATER HARDNESS SENSOR
GI	GREEN	CULCD	CONTROL UNIT LCD
GRY	GREY	ATSW	AUTOMATIC ON OFF SWITCH
GRY	GREY	LCD	LIQUID CRYSTAL DISPLAY
GRY	GREY	PFLT	PARASIT FILTER
GRY	GREY	TRF	TRANSFORMERS LIGHT MODULE
		ALL	AMBI LIGHT LED
		AOD	AUTOMATIC OPEN DOOR
		TFT	TFT LCD
		FC	FERRIT CORE
		WRV	WATER RECYCLING VALF
		WRP	WATER RECYCLING PUMP
		SC	SILICON CABLE
		HIP	HEATER INTEGRATED PUMP
		○	0,25 mm CABLE
		○	0,35 mm CABLE
		○	0,38 mm CABLE
		□	0,50 mm CABLE
		□	0,75 mm CABLE
		△	1,00 mm CABLE
		△	1,50 mm CABLE
		△	1,50 mm SILICON CABLE

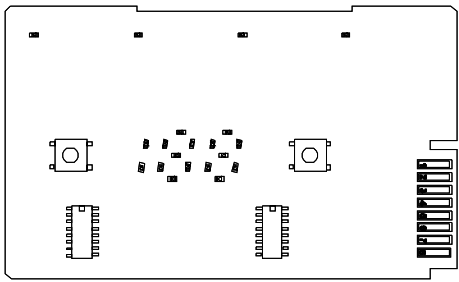

Platine affichage facultative selon modèle

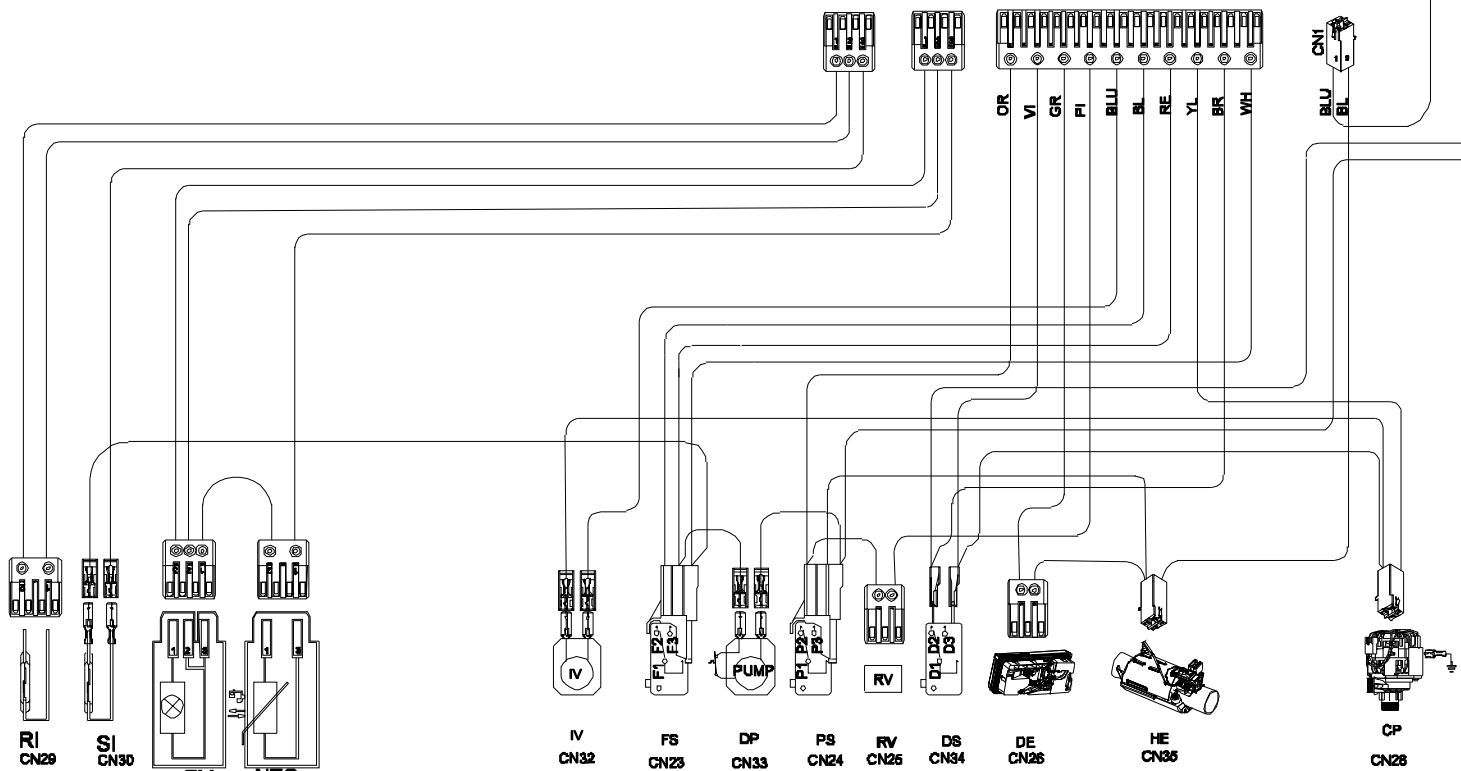
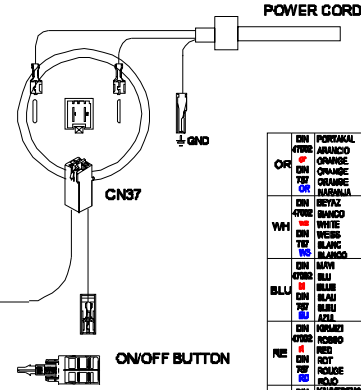
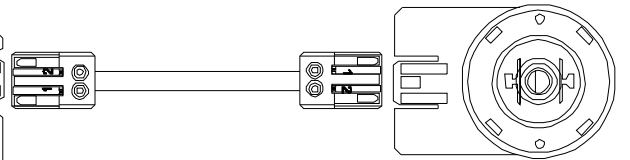
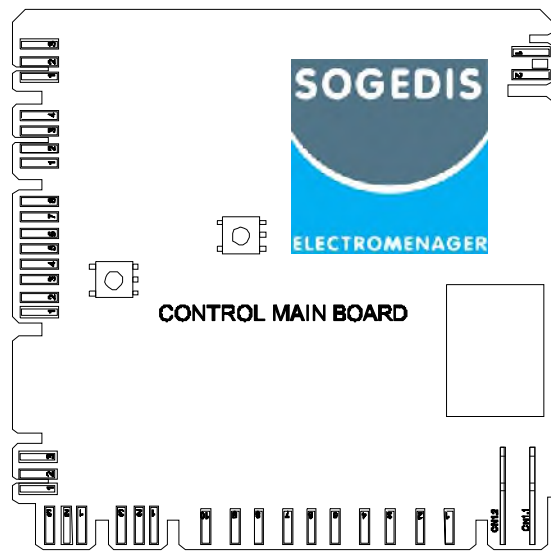

OC	DIN 4706	FORNIAL	TS	TURBIDITY SENSOR
	DIN 4707	ARANCIO	RI	RINSEAD INDICATOR
	DIN 4708	VERDE	SI	SALT INDICATOR
WM	DIN 4709	GRANDE	FM	FLOWMETER
	DIN 4710	BIANCO	NTC	NTC SENSOR
	DIN 4711	NERO	DV	DIVERTER
BLU	DIN 4712	BLANCO	IV	INLET VALVE
	DIN 4713	NERO	FS	FLOAT SENSOR
	DIN 4714	VERDE	DP	DRAIN PUMP
NE	DIN 4715	BLANCO	TF	TURBO FAN
	DIN 4716	VERDE	PS	PRESSURE SWITCH
	DIN 4717	NERO	DS	DOOR SWITCH
BR	DIN 4718	VERDE	DE	AG DISPENSER
	DIN 4719	NERO	HE	HEATING ELEMENT
	DIN 4720	BLANCO	CP	CIRCULATION PUMP
PI	DIN 4721	VERDE	C	CAPASITOR
	DIN 4722	NERO	RV	REGENERATION VALVE
	DIN 4723	BLANCO	SF	HEATING SAFETY
VI	DIN 4724	VERDE	RW	ROTARY SWITCH
	DIN 4725	NERO	BLDC	BLDC PUMP
	DIN 4726	BLANCO	PST	POWER SUPPLY TERMINAL
BL	DIN 4727	VERDE	MS	MAIN SWITCH
	DIN 4728	NERO	DUB	DISPLAY AND USER BOARD
	DIN 4729	BLANCO	U1X	DISPLAY END USER BOARD
GR	DIN 4730	VERDE	U2X	DISPLAY END USER BOARD
	DIN 4731	NERO	U3X	DISPLAY END USER BOARD
	DIN 4732	BLANCO	SFL	SAFETY LOCK
YL	DIN 4733	VERDE	LM	LIGHT MODUL
	DIN 4734	NERO	DCD	DC DISPENSER
	DIN 4735	BLANCO	ALM	AMBIENT LIGHT MODUL
YE	DIN 4736	VERDE	PSW	PRESSURE LEVEL SWITCH
	DIN 4737	NERO	WHS	WATER HARDNESS SENSOR
	DIN 4738	BLANCO	CULCD	CONTROL UNIT LCD
GR	DIN 4739	VERDE	ATSW	AUTOMATIC ON OFF SWITCH
	DIN 4740	NERO	LCD	LIQUID CRYSTAL DISPLAY
	DIN 4741	BLANCO	PFLT	PARASIT FILTER
	DIN 4742	VERDE	TRF	TRANSFORMERS LIGHT MODUL
	DIN 4743	NERO	ALL	AMBI LIGHT LED
	DIN 4744	BLANCO	ACD	AUTOMATICAL OPEN DOOR
			TFT	TFT LCD
			FC	FERRIT CORE
			WRV	WATER RECYCLING VALF
			WRP	WATER RECYCLING PUMP
			SC	SILICON CABLE
			HIP	HEATER INTEGRATED PUMP